



Attachment F

Parkway Peak Hour Traffic Volumes

**26841.01: Sands Integrated Resort
Traffic Impact Study Attachments
Attachment F – Parkway Peak Hour Traffic Volume Figures**



TABLE OF CONTENTS **ATTACHMENT F – PARKWAY PEAK HOUR TRAFFIC VOLUME FIGURES**

F. Parkway Peak Hour Traffic Volume

V-A 2023 Existing Parkway Traffic Volumes

- V-A-1 Weekday AM peak hour
- V-A-2 Weekday PM peak hour
- V-A-3 Friday Evening peak hour
- V-A-4 Saturday Midday peak hour
- V-A-5 Saturday Evening peak hour
- V-A-6 Weekday PM peak hour - Holiday
- V-A-7 Saturday Midday peak hour - Holiday

V-B Combined OPD Parkway Traffic Volumes

- V-B-1 Weekday AM peak hour
- V-B-2 Weekday PM peak hour
- V-B-3 Friday Evening peak hour
- V-B-4 Saturday Midday peak hour
- V-B-5 Saturday Evening peak hour

Full Build (2030) Development

V-C 2030 No-Build Traffic Volumes

- V-C-1 Weekday AM peak hour
- V-C-2 Weekday PM peak hour
- V-C-3 Friday Evening peak hour
- V-C-4 Saturday Midday peak hour
- V-C-5 Saturday Evening peak hour
- V-C-6 Weekday PM peak hour - Holiday
- V-C-7 Saturday Midday peak hour – Holiday

V-D 2030 Trip Assignments

- V-D-1 2030 Combined Trip Assignment – Weekday AM Peak Hour
- V-D-2 2030 Combined Trip Assignment – Weekday PM Peak Hour
- V-D-3 2030 Combined Trip Assignment – Friday Evening Peak Hour
- V-D-4 2030 Combined Trip Assignment – Saturday Midday Peak Hour
- V-D-5 2030 Combined Trip Assignment – Saturday Evening Peak Hour
- V-D-1-1 2030 Trip Assignment - Casino/Hotel – Weekday AM Peak Hour
- V-D-1-2 2030 Trip Assignment - Employee – Weekday AM Peak Hour
- V-D-1-3 2030 Trip Assignment - Restaurant/Retail/Public Attraction, Theater, Meetings and Conference– Weekday AM Peak Hour
- V-D-1-4 2030 Trip Assignment - Ridehailing – Weekday AM Peak Hour
- V-D-2-1 2030 Trip Assignment - Casino/Hotel – Weekday PM Peak Hour
- V-D-2-2 2030 Trip Assignment - Employee – Weekday PM Peak Hour

TABLE OF CONTENTS **ATTACHMENT F – PARKWAY PEAK HOUR TRAFFIC VOLUME FIGURES**

- V-D-2-3 2030 Trip Assignment - Restaurant/Retail/Public Attraction, Theater, Meetings and Conference– Weekday PM Peak Hour
- V-D-2-4 2030 Trip Assignment - Ridehailing – Weekday PM Peak Hour
- V-D-3-1 2030 Trip Assignment - Casino/Hotel – Friday Evening Peak Hour
- V-D-3-2 2030 Trip Assignment - Employee – Friday Evening Peak Hour
- V-D-3-3 2030 Trip Assignment - Restaurant/Retail/Public Attraction, Theater, Meetings and Conference– Friday Evening Peak Hour
- V-D-3-4 2030 Trip Assignment - Ridehailing – Friday Evening Peak Hour
- V-D-4-1 2030 Trip Assignment - Casino/Hotel – Saturday Midday Peak Hour
- V-D-4-2 2030 Trip Assignment - Employee – Saturday Midday Peak Hour
- V-D-4-3 2030 Trip Assignment - Restaurant/Retail/Public Attraction, Theater, Meetings and Conference– Saturday Midday AM Peak Hour
- V-D-4-4 2030 Trip Assignment - Ridehailing – Saturday Midday Peak Hour
- V-D-5-1 2030 Trip Assignment - Casino/Hotel – Saturday Evening Peak Hour
- V-D-5-2 2030 Trip Assignment - Employee – Saturday Evening Peak Hour
- V-D-5-3 2030 Trip Assignment - Restaurant/Retail/Public Attraction, Theater, Meetings and Conference– Saturday Evening AM Peak Hour
- V-D-5-4 2030 Trip Assignment - Ridehailing – Saturday Evening Peak Hour

V-E 2030 Build Traffic Volumes

- V-E-1 2030 Build Traffic Volumes - Weekday AM Peak Hour
- V-E-2 2030 Build Traffic Volumes - Weekday PM Peak Hour
- V-E-3 2030 Build Traffic Volumes - Friday Evening Peak Hour
- V-E-4 2030 Build Traffic Volumes - Saturday Midday Peak Hour
- V-E-5 2030 Build Traffic Volumes - Saturday Evening Peak Hour
- V-E-6 2030 Build Traffic Volumes - Weekday PM Peak Hour- Holiday
- V-E-7 2030 Build Traffic Volumes - Saturday Midday Peak Hour – Holiday

Phase 1 (2027) Development

V-C 2027 No-Build Traffic Volumes

- V-C-8 2027 No-Build Traffic Volumes - Weekday AM Peak Hour
- V-C-9 2026 No-Build Traffic Volumes - Weekday PM Peak Hour
- V-C-10 2027 No-Build Traffic Volumes - Friday Evening Peak Hour
- V-C-11 2027 No-Build Traffic Volumes - Saturday Midday Peak Hour
- V-C-12 2027 No-Build Traffic Volumes - Saturday Evening Peak Hour
- V-C-13 2027 No-Build Traffic Volumes - Weekday PM Peak Hour- Holiday
- V-C-14 2027 No-Build Traffic Volumes - Saturday Midday Peak Hour – Holiday

V-E 2027 Build Traffic Volumes

- V-E-8 2030 Build Traffic Volumes - Weekday AM Peak Hour
- V-E-9 2030 Build Traffic Volumes - Weekday PM Peak Hour
- V-E-10 2030 Build Traffic Volumes - Friday Evening Peak Hour



TABLE OF CONTENTS **ATTACHMENT F – PARKWAY PEAK HOUR TRAFFIC VOLUME FIGURES**

- V-E-11 2030 Build Traffic Volumes - Saturday Midday Peak Hour
- V-E-12 2030 Build Traffic Volumes - Saturday Evening Peak Hour
- V-E-13 2030 Build Traffic Volumes - Weekday PM Peak Hour- Holiday
- V-E-14 2030 Build Traffic Volumes - Saturday Midday Peak Hour – Holiday

Alternative Analysis

F Alternative Analysis Trip Assignment

- V-F-1 2030 Trip Assignment - Alternative - Weekday AM Peak Hour
- V-F-2 2030 Trip Assignment - Alternative - Weekday PM Peak Hour
- V-F-3 2030 Trip Assignment - Alternative - Saturday Midday Peak Hour

G Alternative Analysis Build Traffic Volumes

- V-G-1 2030 Build Traffic Volumes - Alternative - Weekday AM Peak Hour
- V-G-2 2030 Build Traffic Volumes - Alternative - Weekday PM Peak Hour
- V-G-3 2030 Build Traffic Volumes - Alternative - Saturday Midday Peak Hour

**26841.01: Sands Integrated Resort
Traffic Impact Study Attachments
Attachment F – Parkway Peak Hour Traffic Volume Figures**





V-A 2023 Existing Traffic Volumes

**26841.01: Sands Integrated Resort
Traffic Impact Study Attachments
Attachment F – Parkway Peak Hour Traffic Volume Figures**



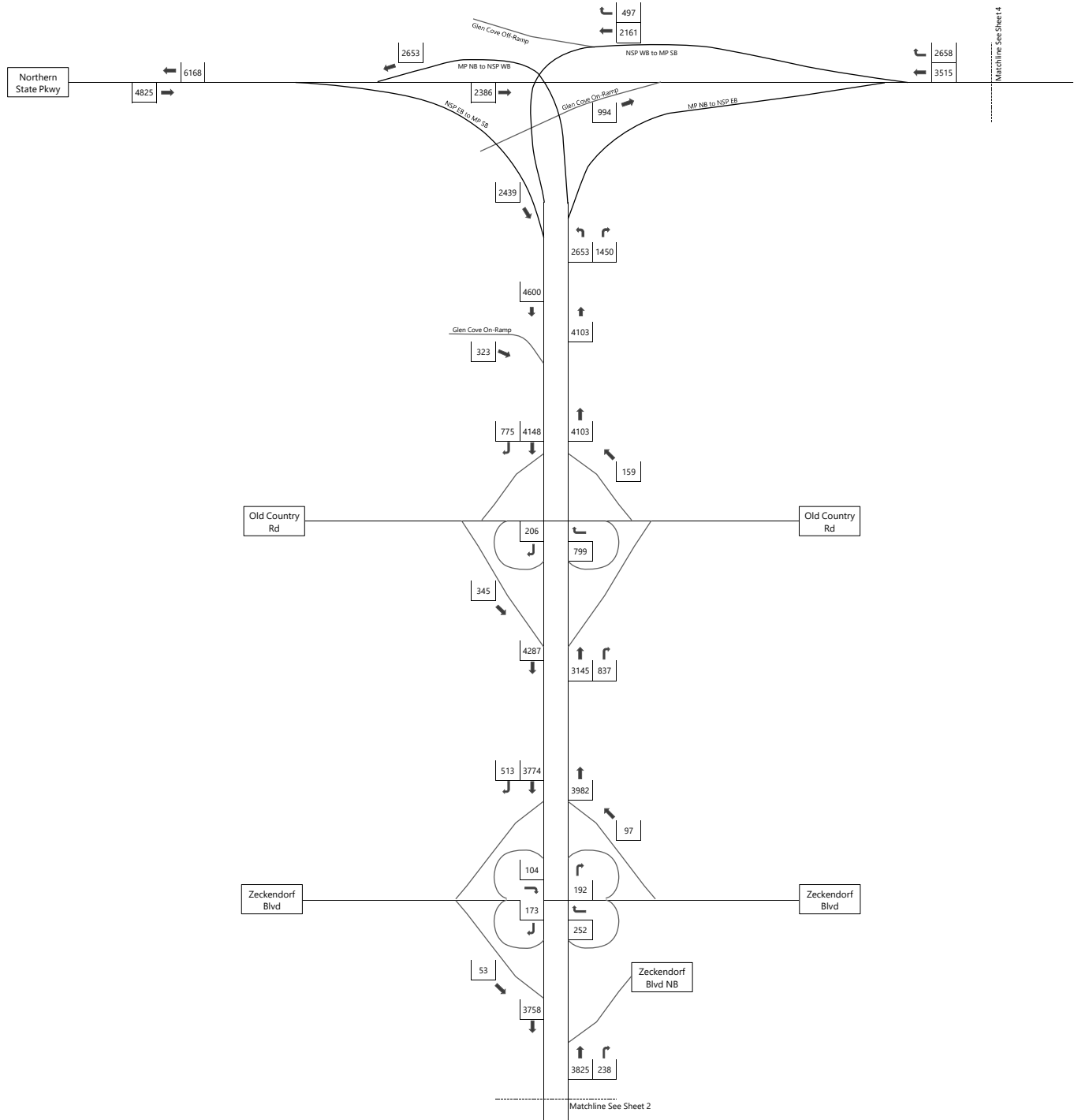

Figure V-A-1, Sheet 1
 2023 Existing Parkway Traffic Volumes
 Weekday AM Peak Hour
 26841.01 - Sands New York Integrated Resort
 Meadowbrook State Parkway



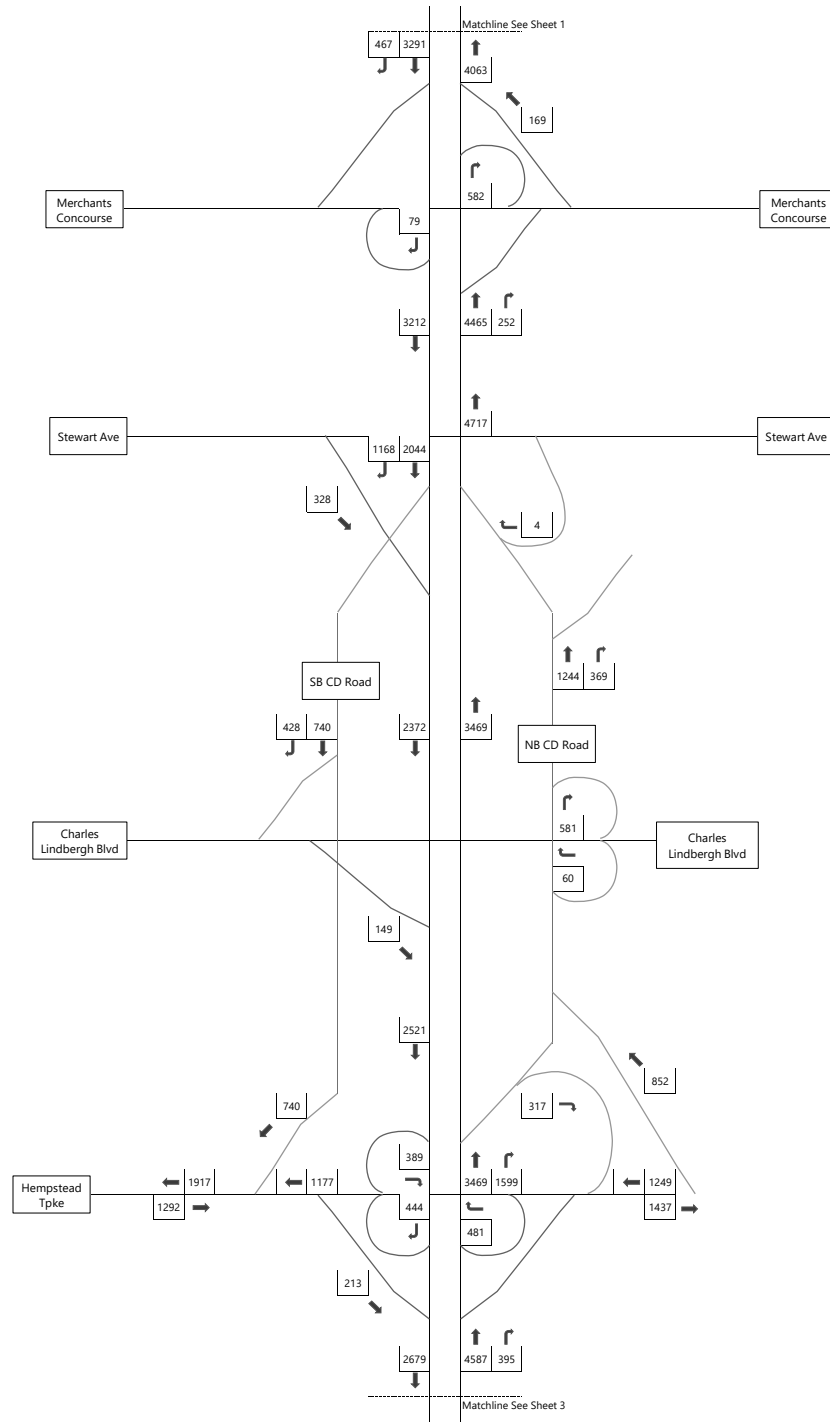

Figure V-A-1, Sheet 2
 2023 Existing Parkway Traffic Volumes
 Weekday AM Peak Hour
 26841.01 - Sands New York Integrated Resort
 Meadowbrook State Parkway



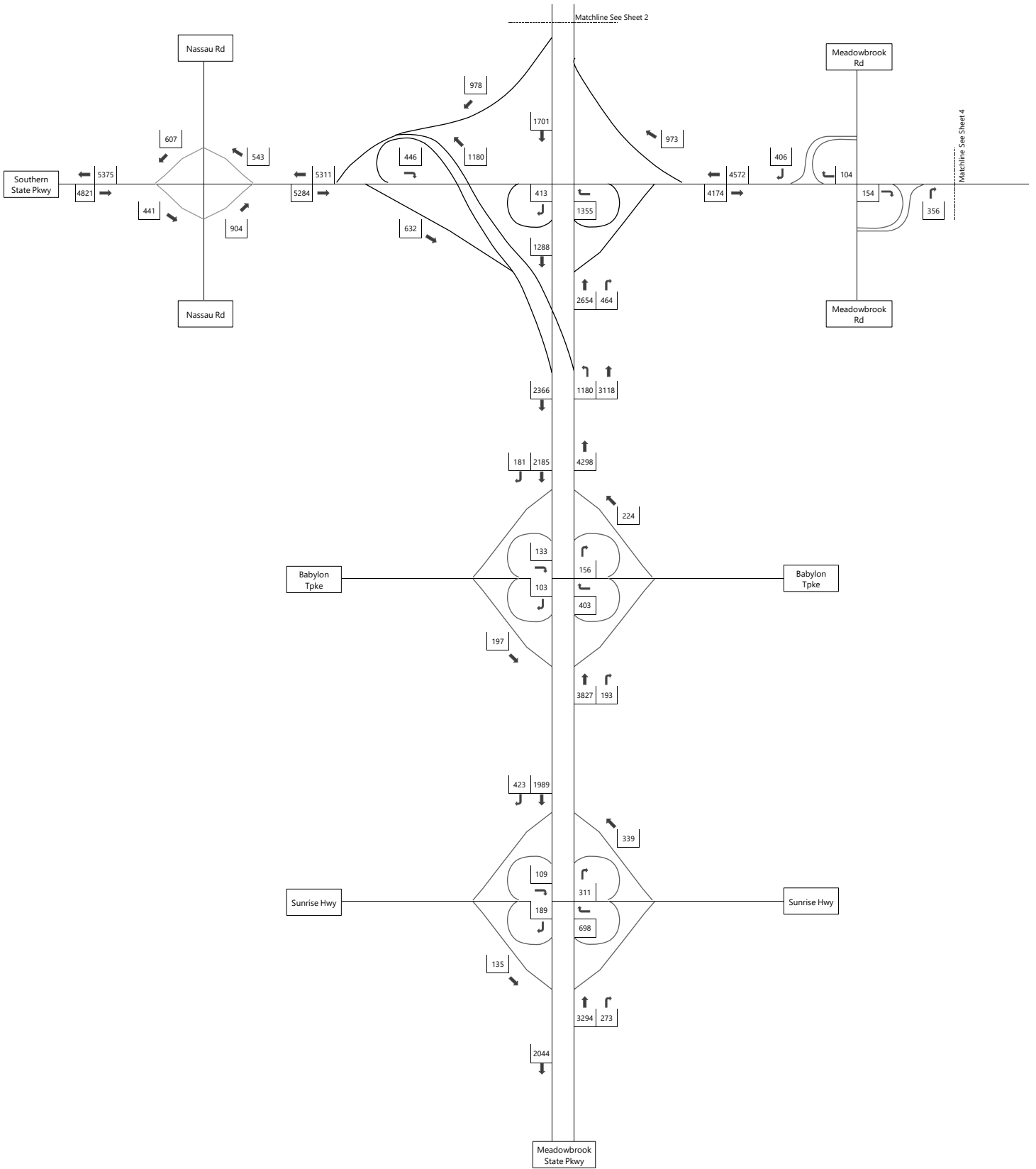

Figure V-A-1, Sheet 3
 2023 Existing Parkway Traffic Volumes
 Weekday AM Peak Hour
 26841.01 - Sands New York Integrated Resort
 Meadowbrook State Parkway



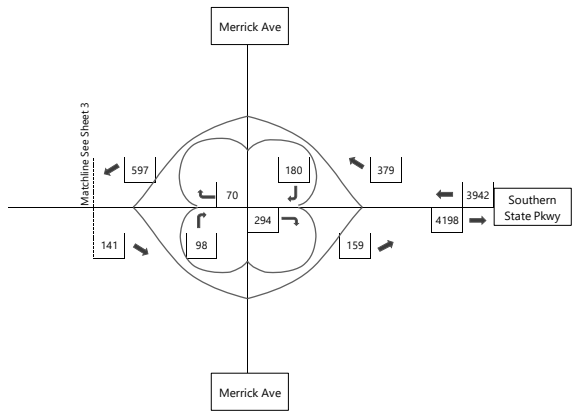
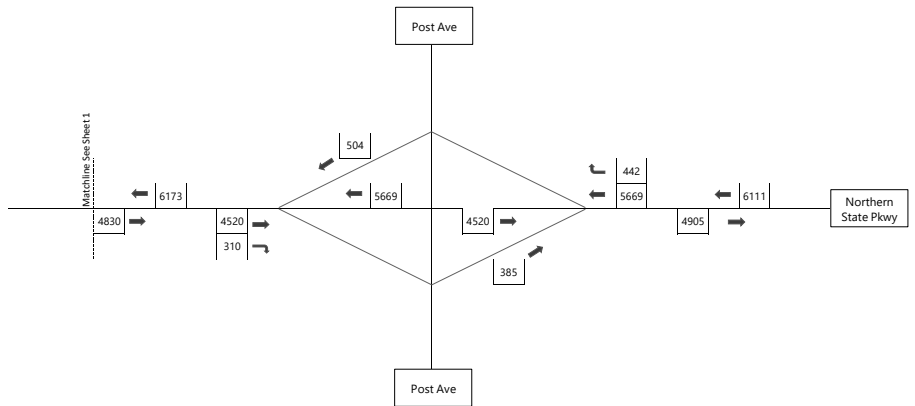

Figure V-A-1, Sheet 4
 2023 Existing Parkway Traffic Volumes
 Weekday AM Peak Hour
 26841.01 - Sands New York Integrated Resort
 Meadowbrook State Parkway



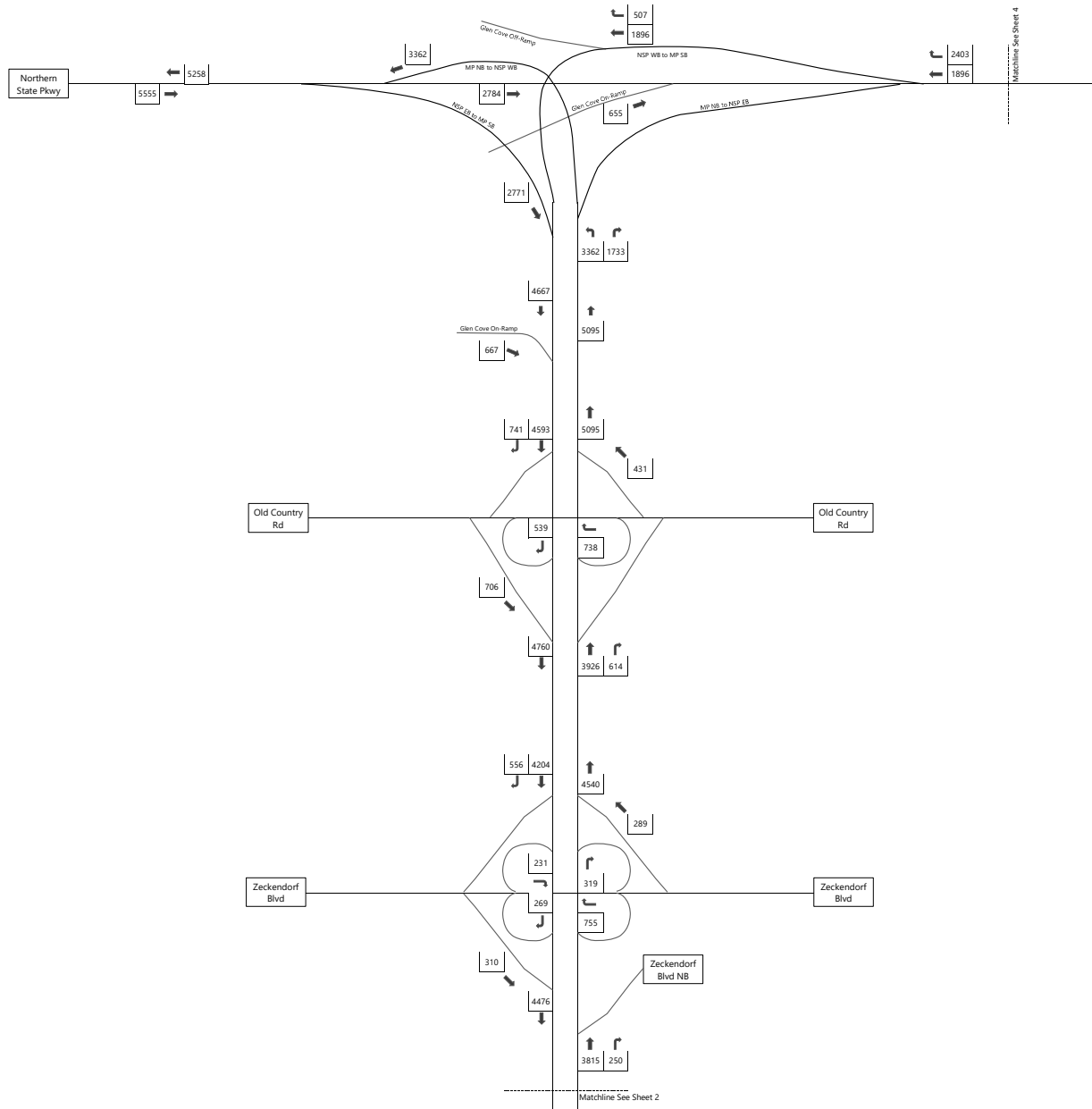

Figure V-A-2, Sheet 1
 2023 Existing Parkway Traffic Volumes
 Weekday PM Peak Hour
 26841.01 - Sands New York Integrated Resort
 Meadowbrook State Parkway



Not to Scale



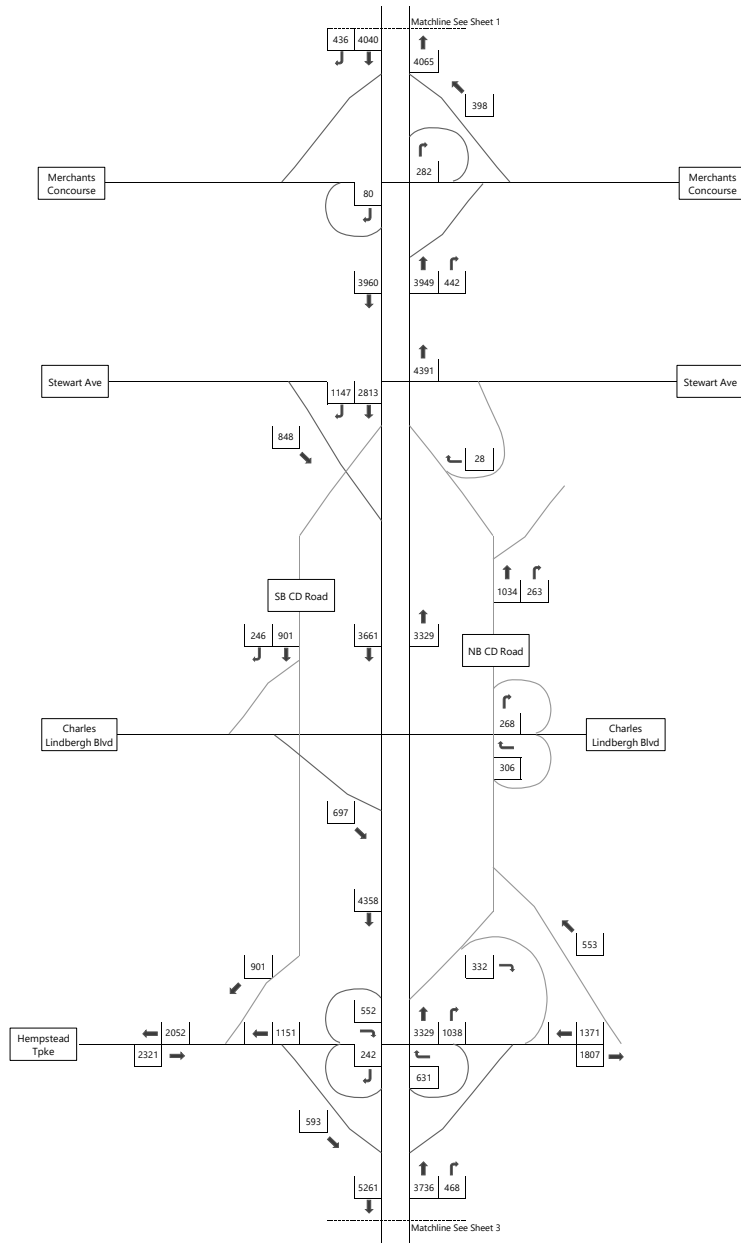

Figure V-A-2, Sheet 2
 2023 Existing Parkway Traffic Volumes
 Weekday PM Peak Hour
 26841.01 - Sands New York Integrated Resort
 Meadowbrook State Parkway



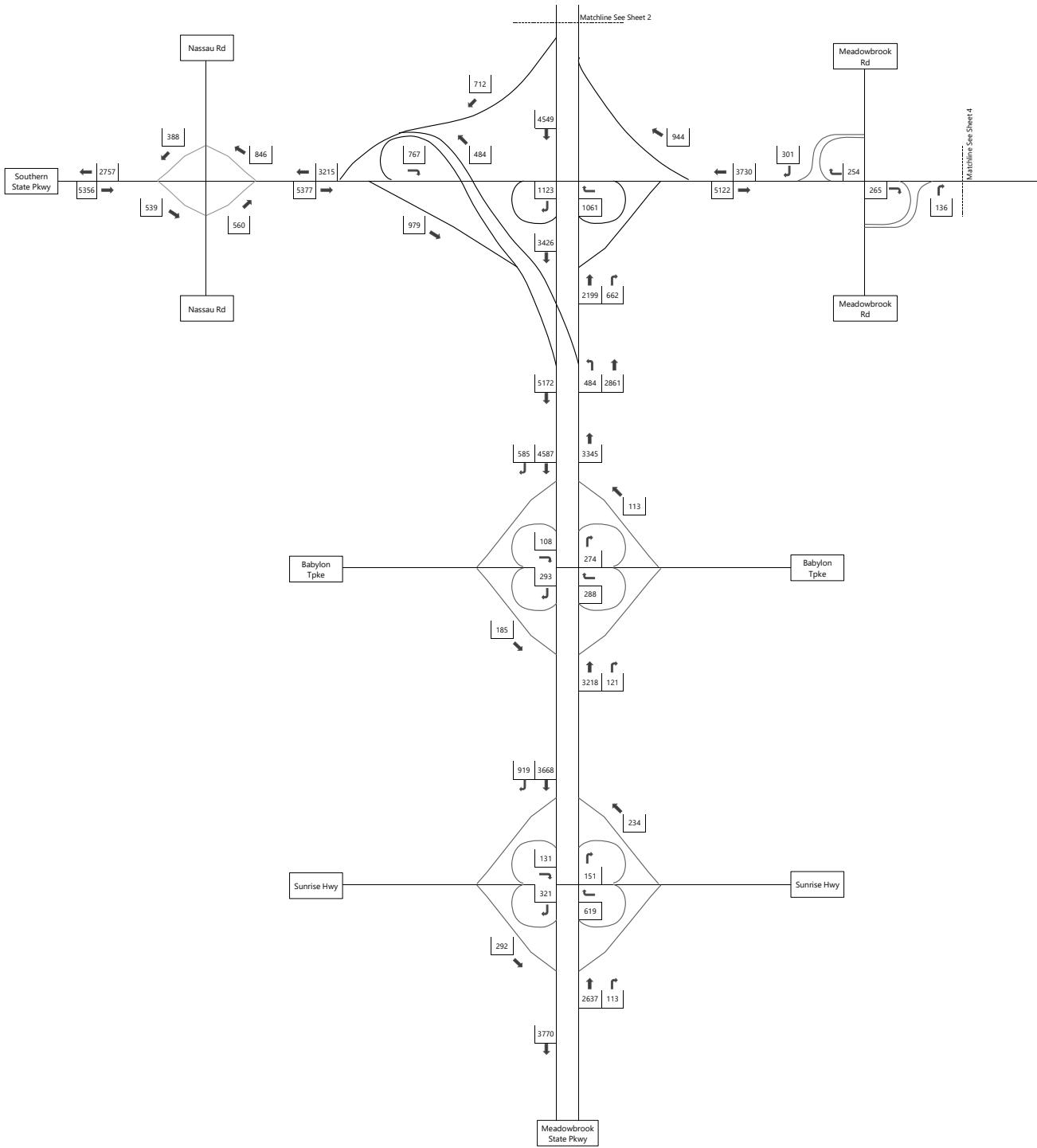

Figure V-A-2, Sheet 3
 2023 Existing Parkway Traffic Volumes
 Weekday PM Peak Hour
 26841.01 - Sands New York Integrated Resort
 Meadowbrook State Parkway



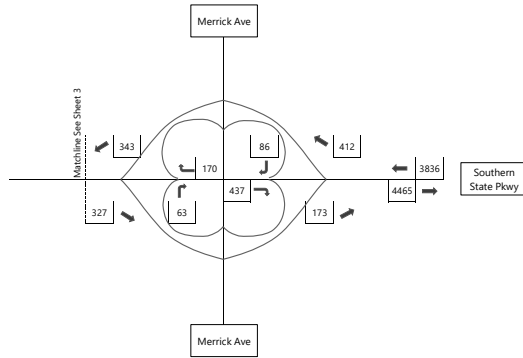
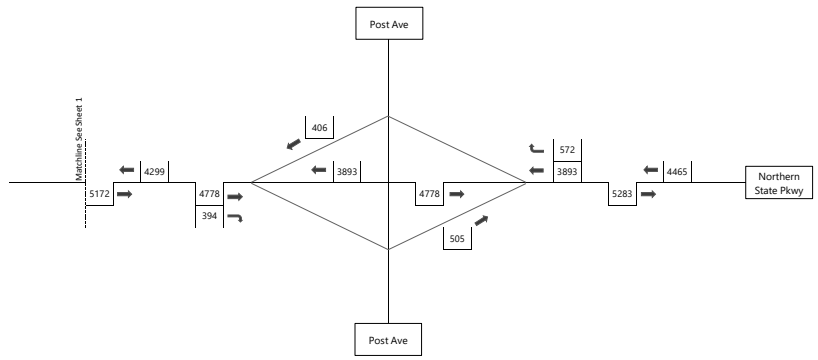

Figure V-A-2, Sheet 4
 2023 Existing Parkway Traffic Volumes
 Weekday PM Peak Hour
 26841.01 - Sands New York Integrated Resort
 Meadowbrook State Parkway



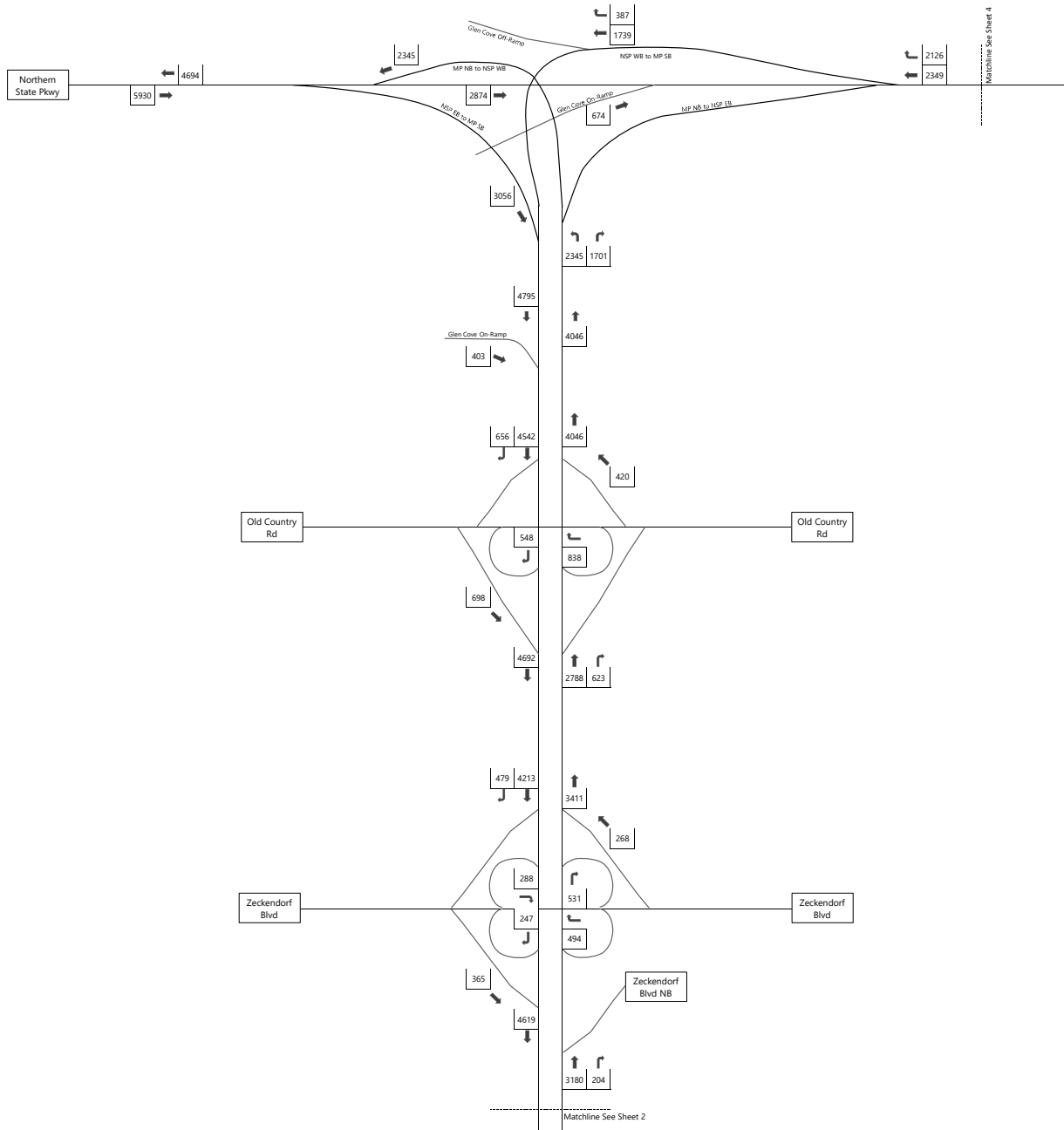

Figure V-A-3, Sheet 1
 2023 Existing Parkway Traffic Volumes
 Friday Evening Peak Hour
 26841.01 - Sands New York Integrated Resort
 Meadowbrook State Parkway



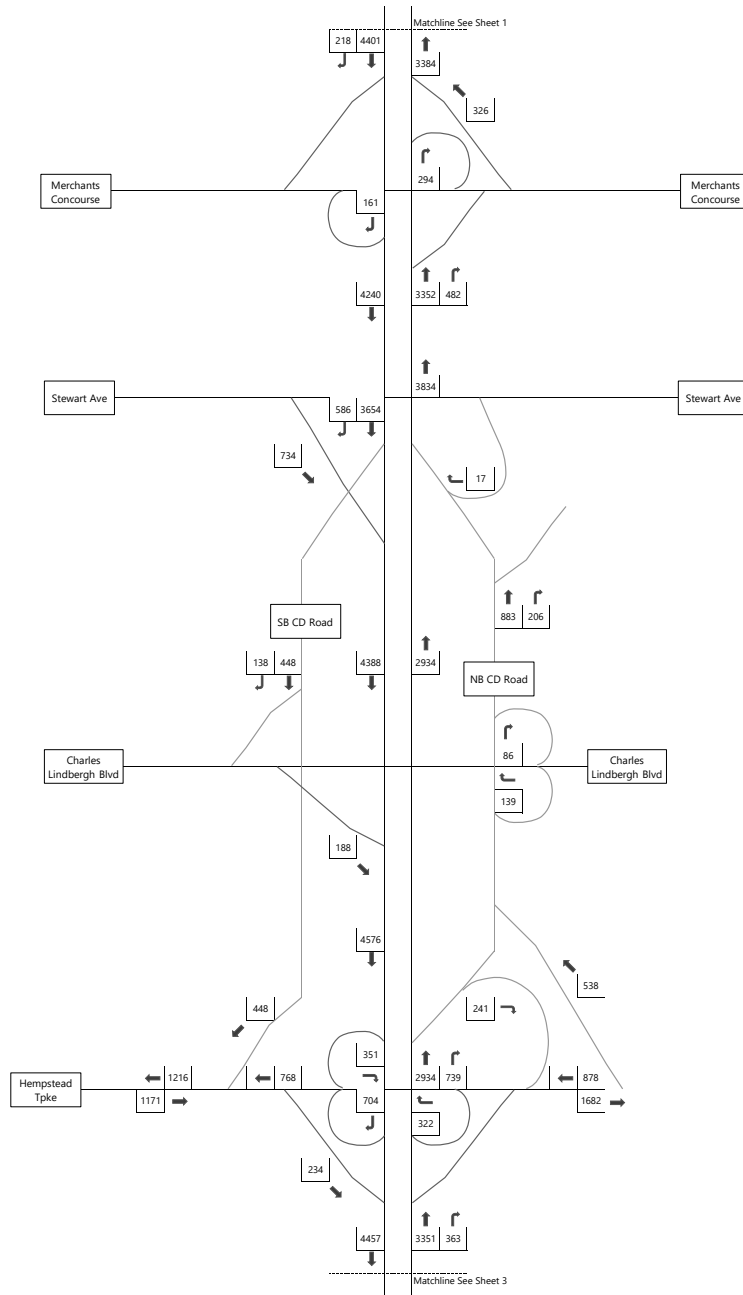

Figure V-A-3, Sheet 2
 2023 Existing Parkway Traffic Volumes
 Friday Evening Peak Hour
 26841.01 - Sands New York Integrated Resort
 Meadowbrook State Parkway



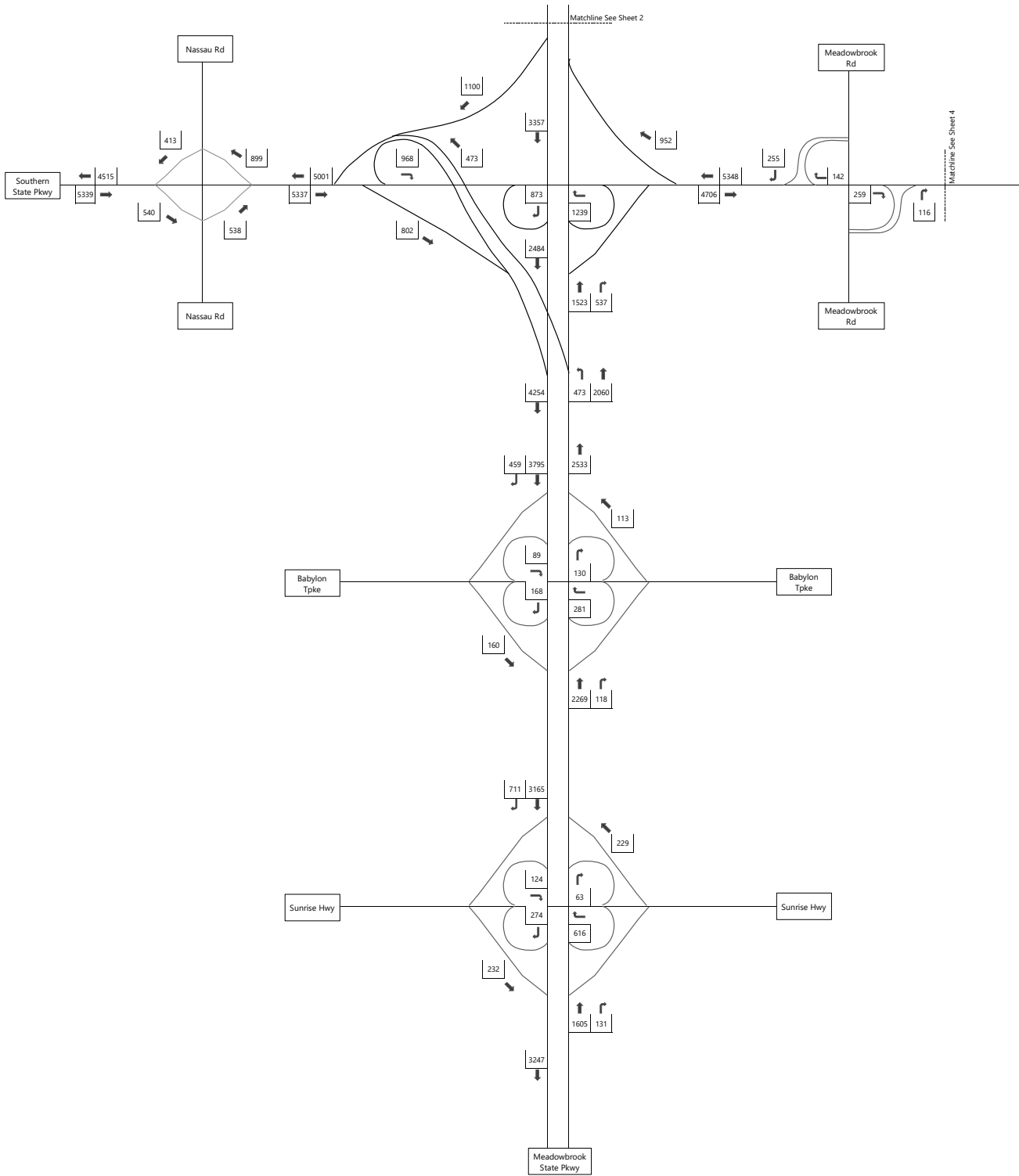

Figure V-A-3, Sheet 3
 2023 Existing Parkway Traffic Volumes
 Friday Evening Peak Hour
 26841.01 - Sands New York Integrated Resort
 Meadowbrook State Parkway



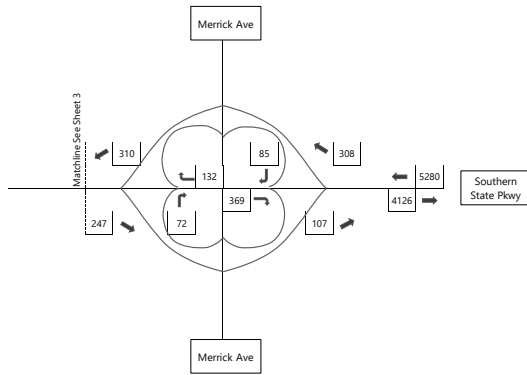
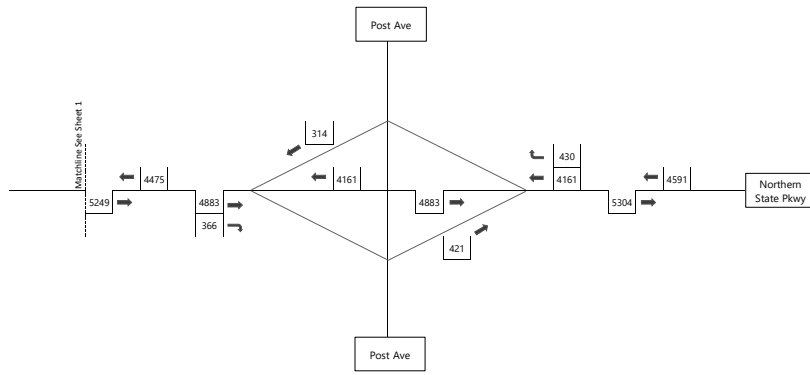

Figure V-A-3, Sheet 4
 2023 Existing Parkway Traffic Volumes
 Friday Evening Peak Hour
 26841.01 - Sands New York Integrated Resort
 Meadowbrook State Parkway



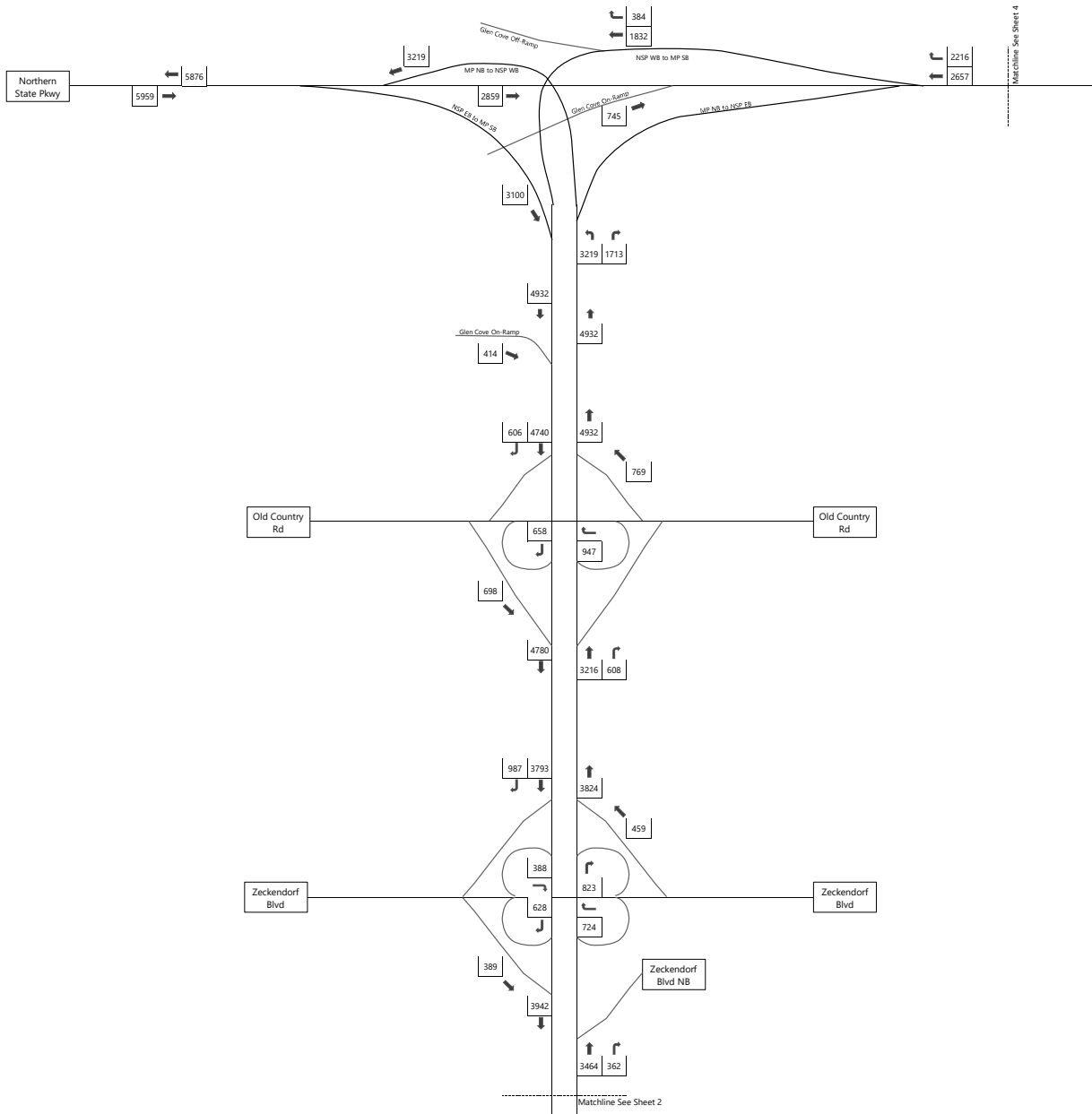

Figure V-A-4, Sheet 1
 2023 Existing Parkway Traffic Volumes
 Saturday Midday Peak Hour
 26841.01 - Sands New York Integrated Resort
 Meadowbrook State Parkway



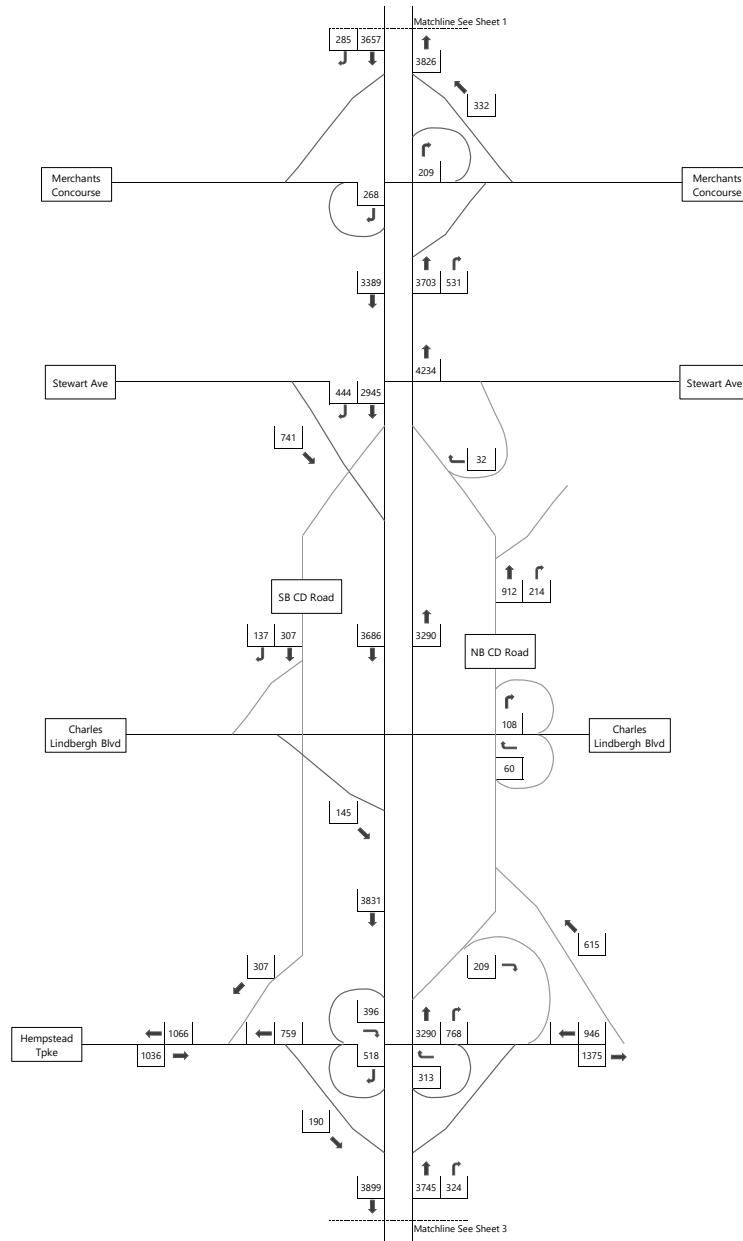

Figure V-A-4, Sheet 2
 2023 Existing Parkway Traffic Volumes
 Saturday Midday Peak Hour
 26841.01 - Sands New York Integrated Resort
 Meadowbrook State Parkway



Not to Scale



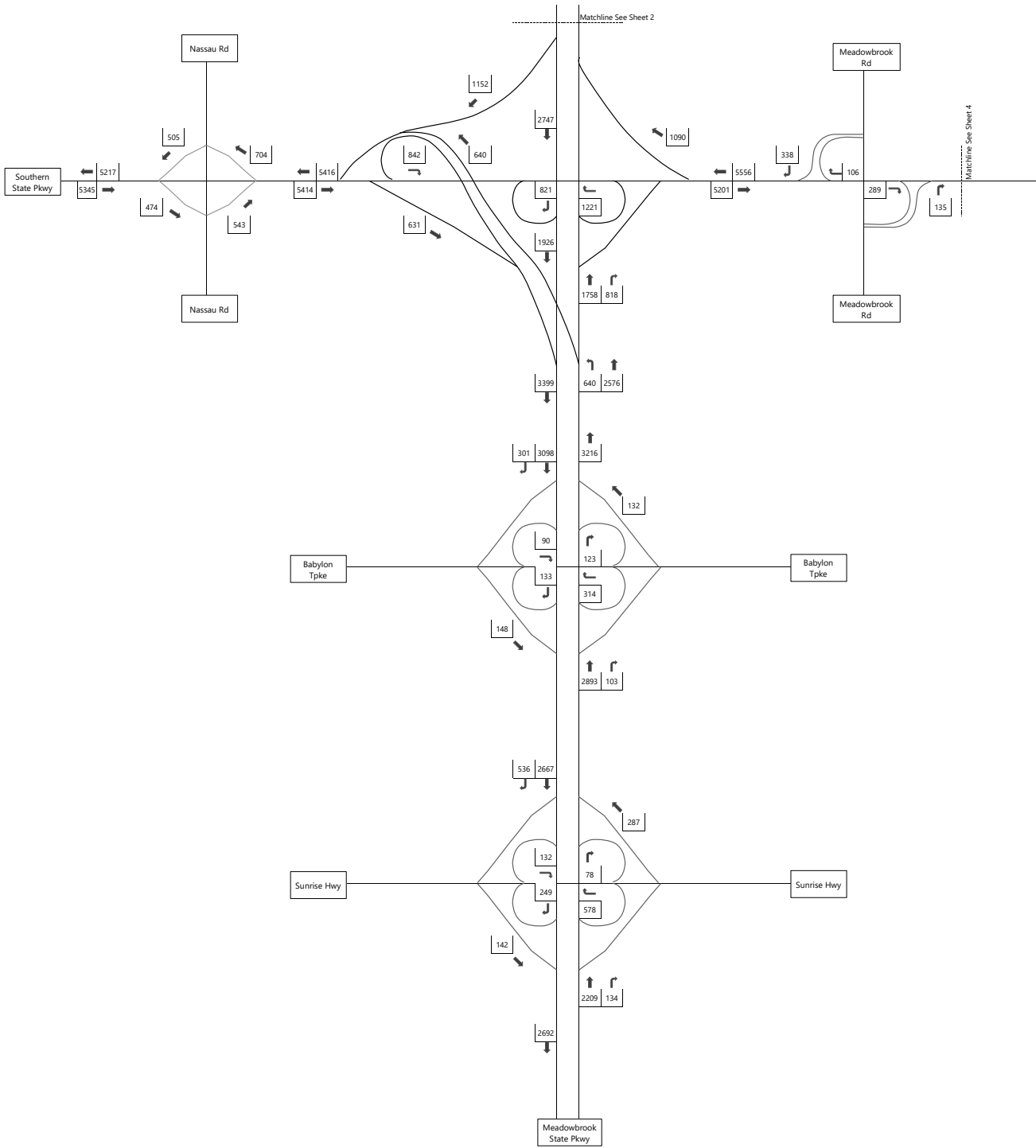

Figure V-A-4, Sheet 3
 2023 Existing Parkway Traffic Volumes
 Saturday Midday Peak Hour
 26841.01 - Sands New York Integrated Resort
 Meadowbrook State Parkway



Not to Scale



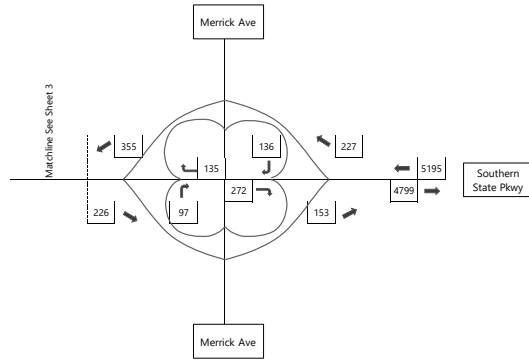
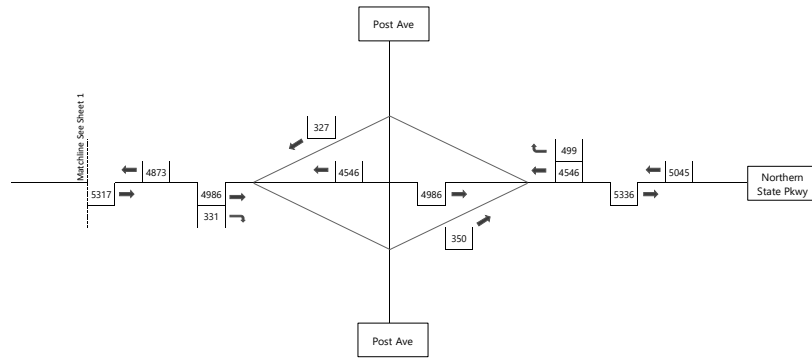

Figure V-A-4, Sheet 4
 2023 Existing Parkway Traffic Volumes
 Saturday Midday Peak Hour
 26841.01 - Sands New York Integrated Resort
 Meadowbrook State Parkway



Not to Scale



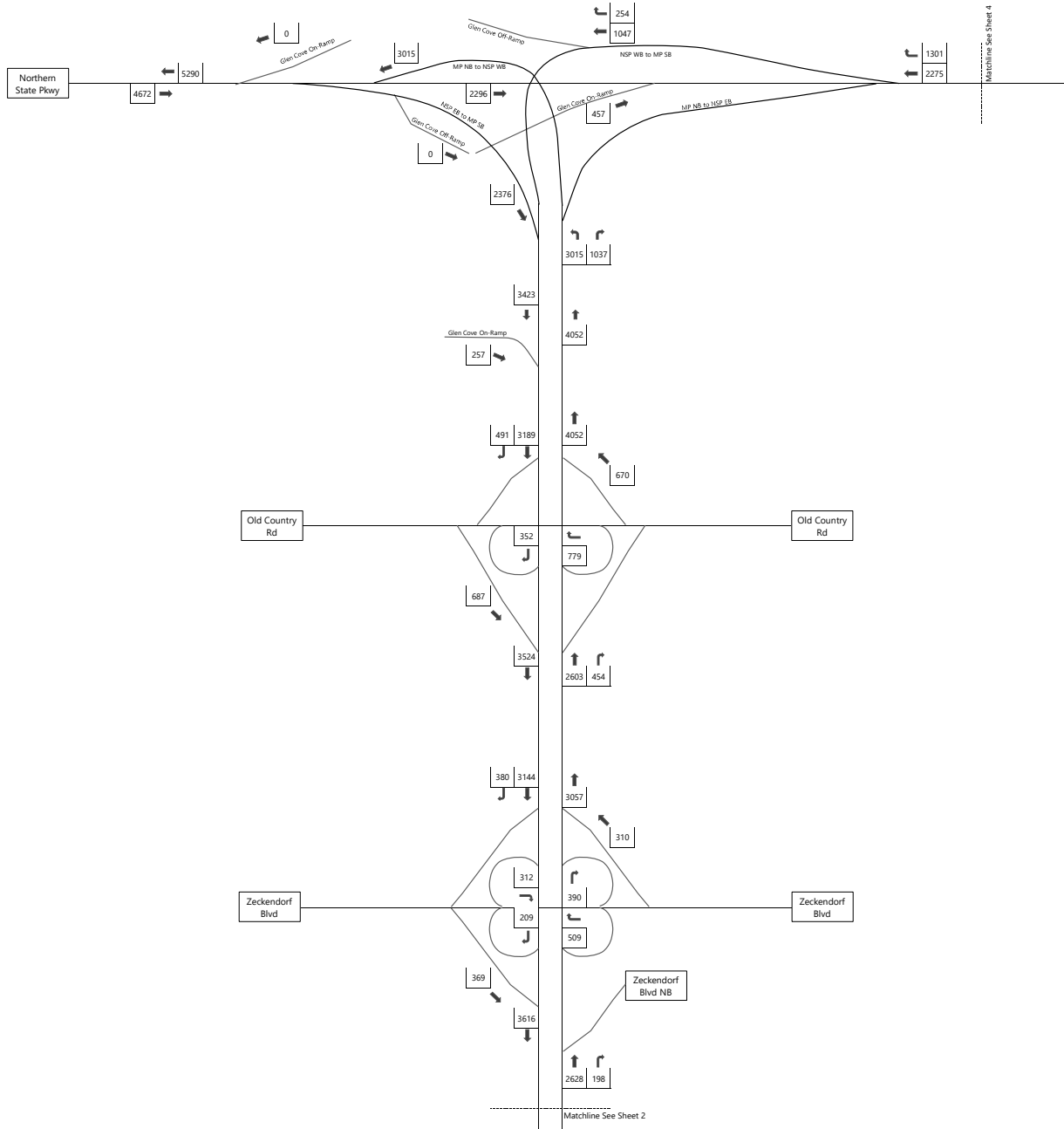

Figure V-A-5, Sheet 1
 2023 Existing Parkway Traffic Volumes
 Saturday Evening Peak Hour
 26841.01 - Sands New York Integrated Resort
 Meadowbrook State Parkway



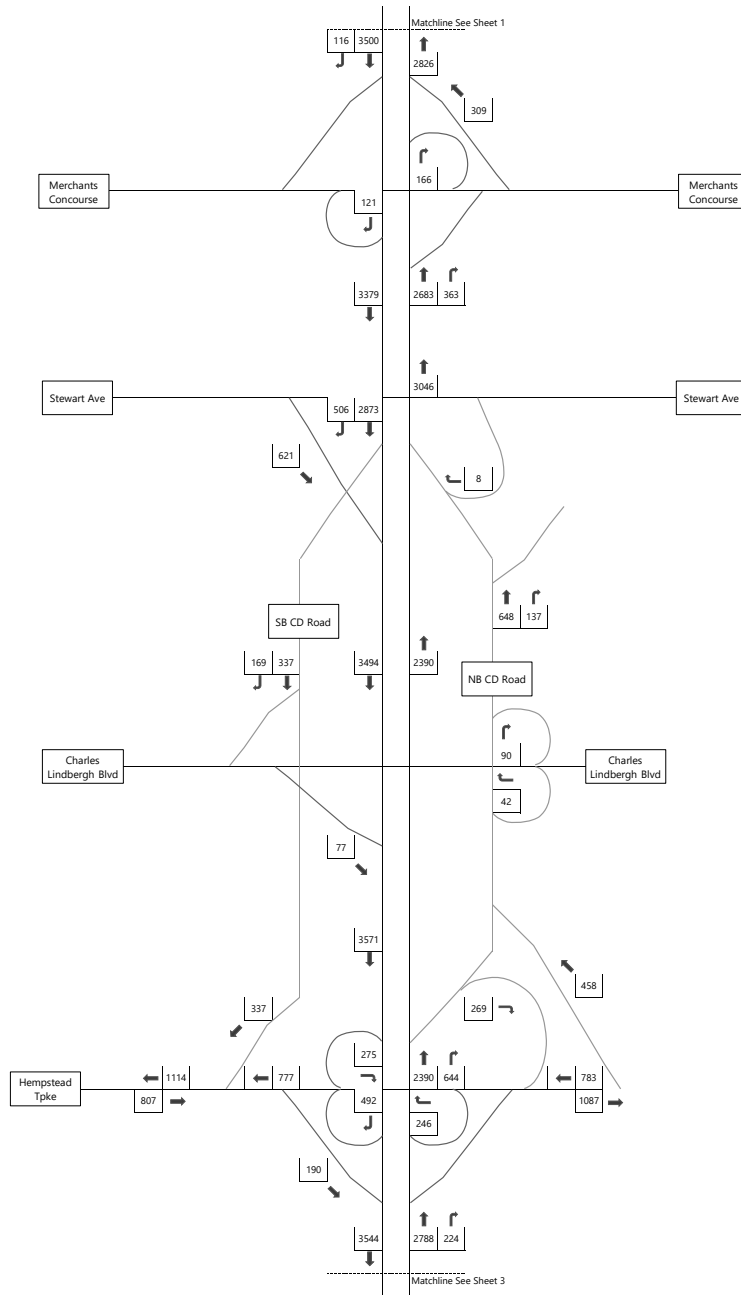

Figure V-A-5, Sheet 2
 2023 Existing Parkway Traffic Volumes
 Saturday Evening Peak Hour
 26841.01 - Sands New York Integrated Resort
 Meadowbrook State Parkway



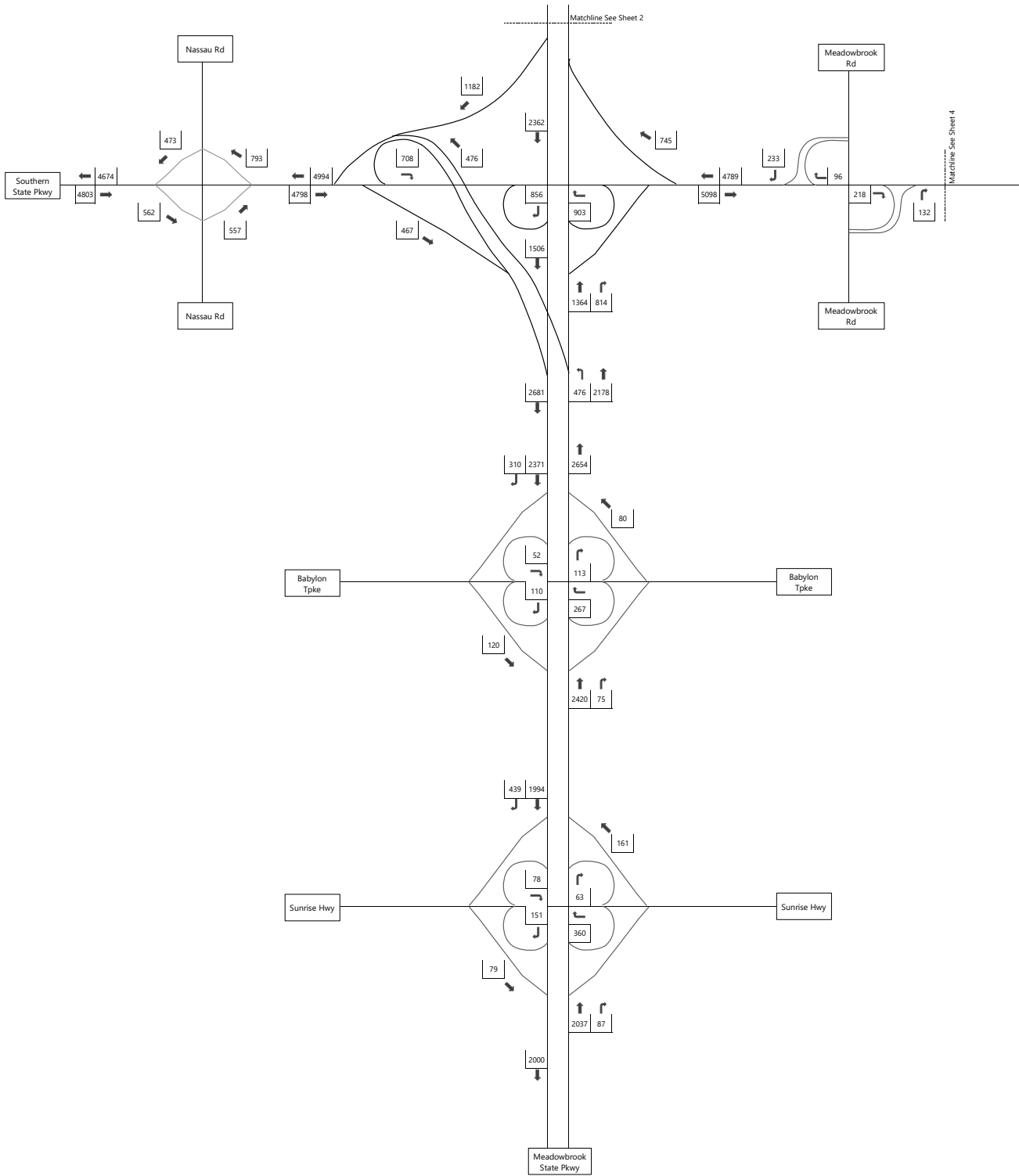

Figure V-A-5, Sheet 3
 2023 Existing Parkway Traffic Volumes
 Saturday Evening Peak Hour
 26841.01 - Sands New York Integrated Resort
 Meadowbrook State Parkway



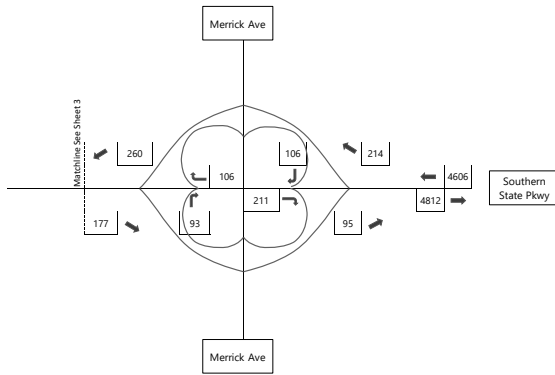
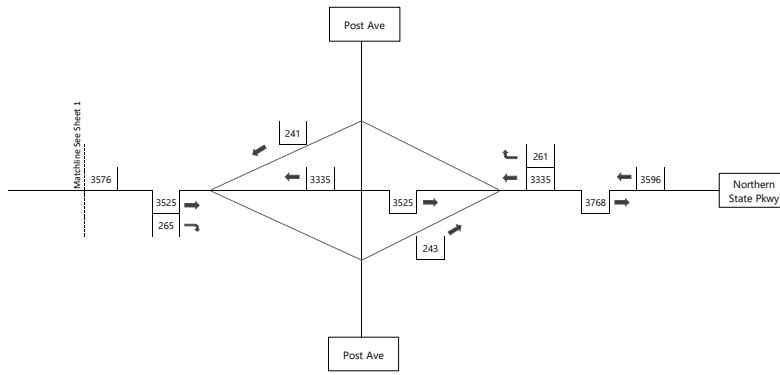

Figure V-A-5, Sheet 4
 2023 Existing Parkway Traffic Volumes
 Saturday Evening Peak Hour
 26841.01 - Sands New York Integrated Resort
 Meadowbrook State Parkway



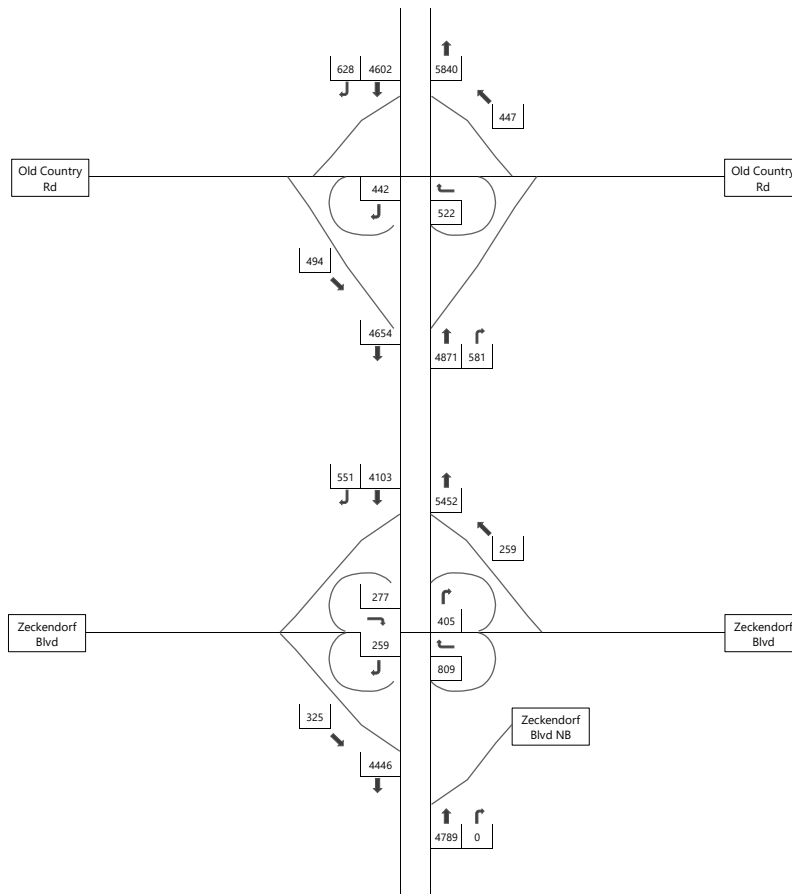

Figure V-A-6, Sheet 1
 2023 Existing Traffic Volumes
 Weekday PM Peak Hour - Holiday
 26841.01 - Sands New York Integrated Resort
 Meadowbrook State Parkway



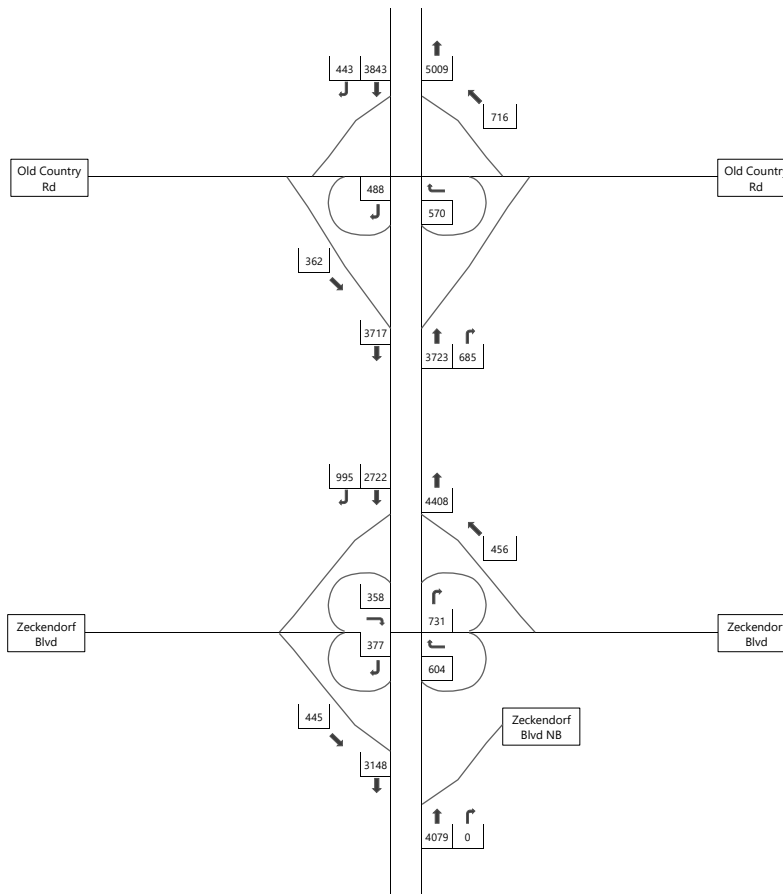

Figure V-A-7, Sheet 1
 2023 Existing Traffic Volumes
 Saturday Midday Peak Hour - Holiday
 26841.01 - Sands New York Integrated Resort
 Meadowbrook State Parkway





V-B Combined OPD Traffic Volumes

**26841.01: Sands Integrated Resort
Traffic Impact Study Attachments
Attachment F – Parkway Peak Hour Traffic Volume Figures**



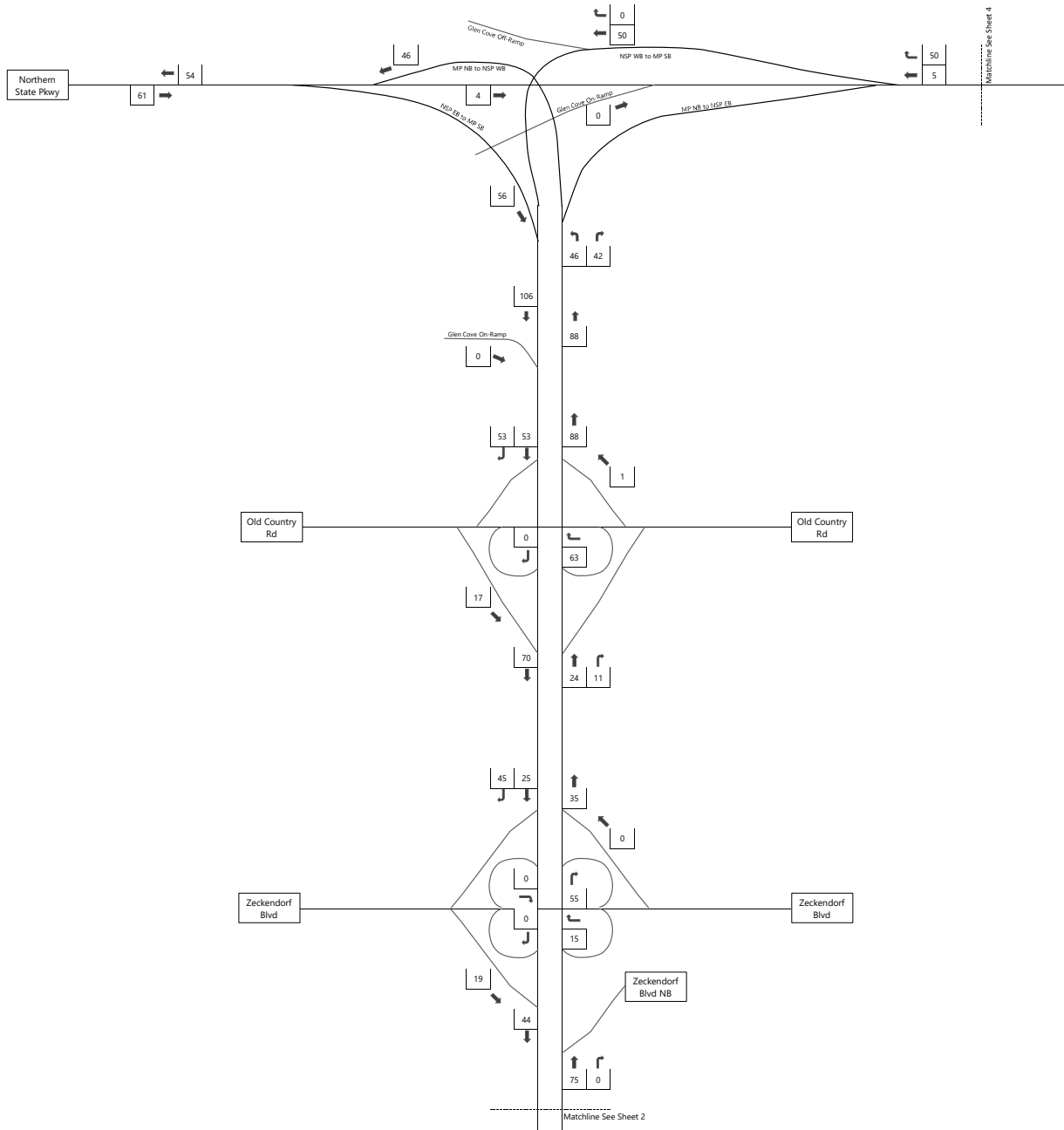

Figure V-B-1, Sheet 1
 Combined OPD Parkway Traffic Volumes
 Weekday AM Peak Hour
 26841.01 - Sands New York Integrated Resort
 Meadowbrook State Parkway



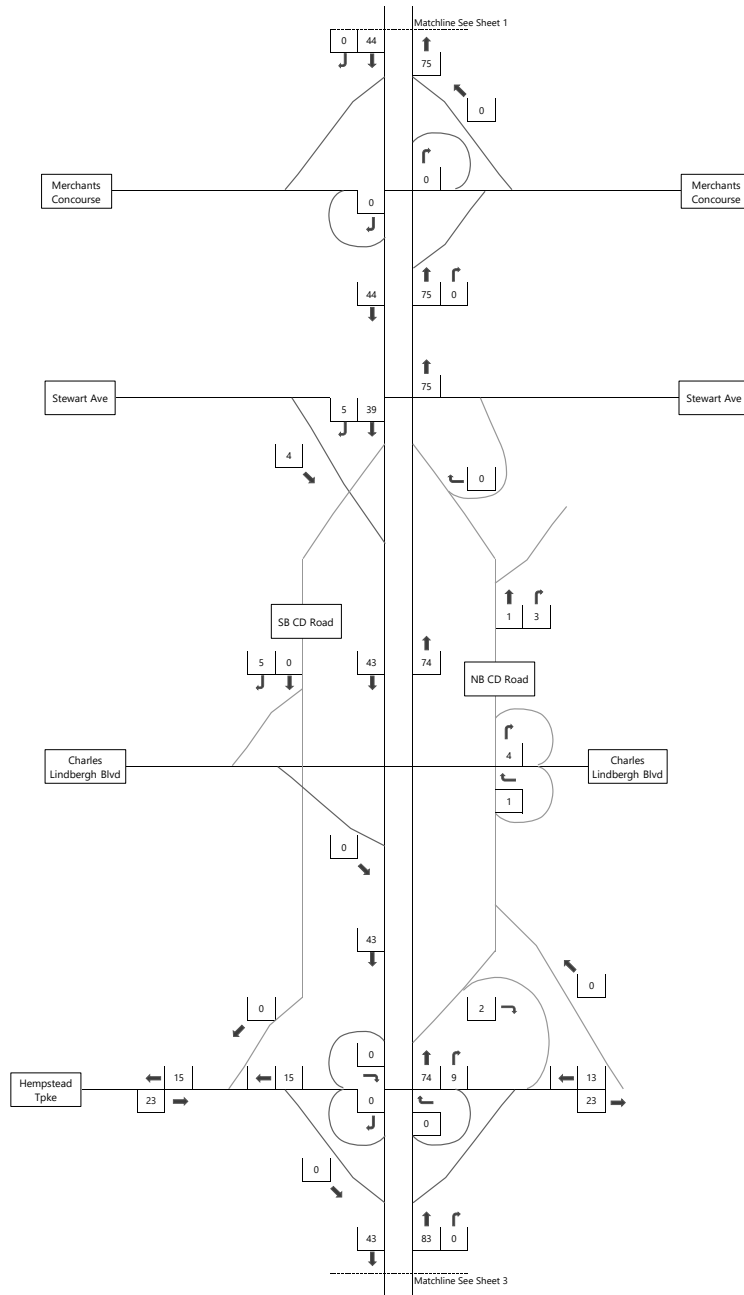

Figure V-B-1, Sheet 2
 Combined OPD Parkway Traffic Volumes
 Weekday AM Peak Hour
 26841.01 - Sands New York Integrated Resort
 Meadowbrook State Parkway



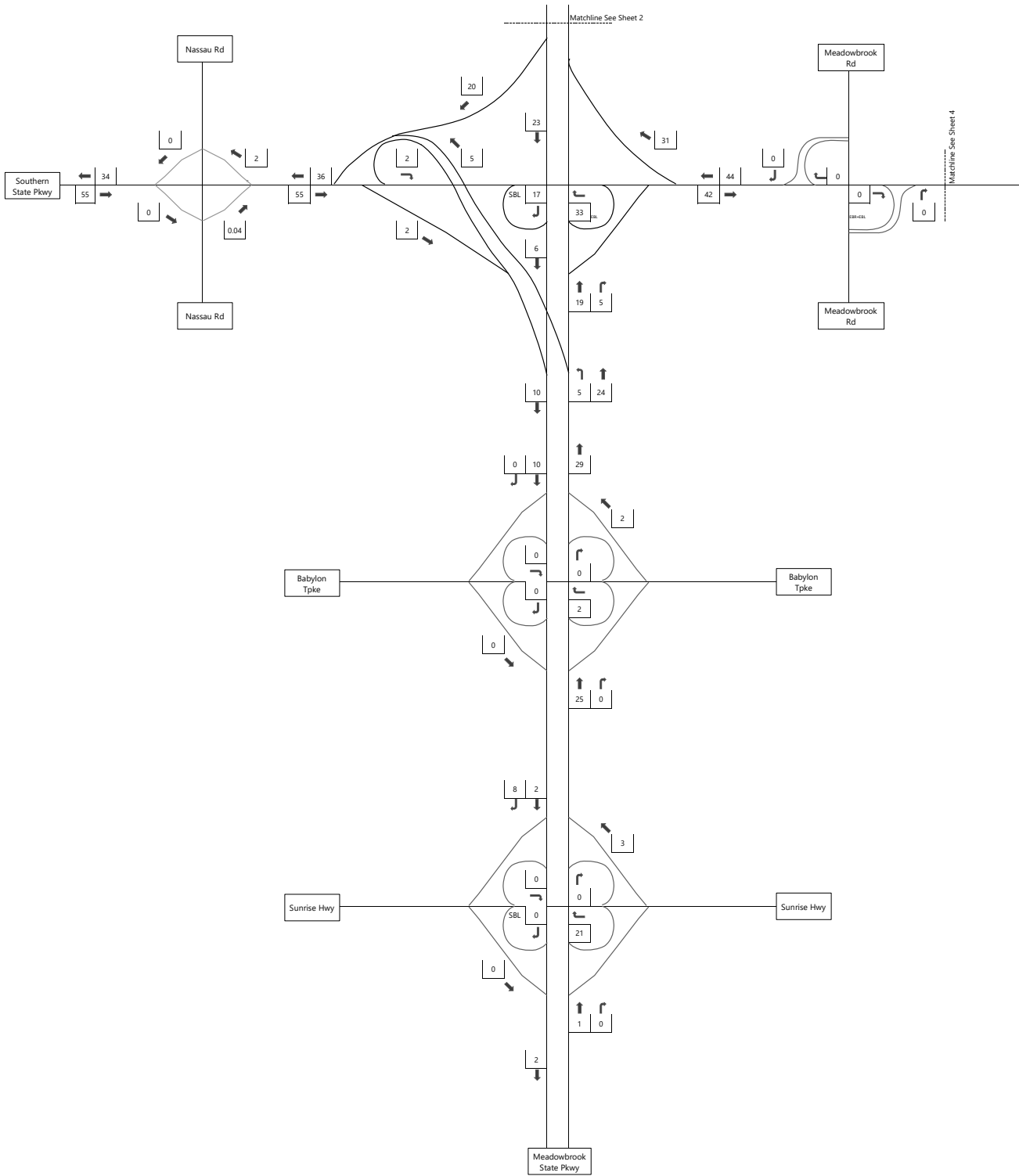

Figure V-B-1, Sheet 3
 Combined OPD Parkway Traffic Volumes
 Weekday AM Peak Hour
 26841.01 - Sands New York Integrated Resort
 Meadowbrook State Parkway



Not to Scale



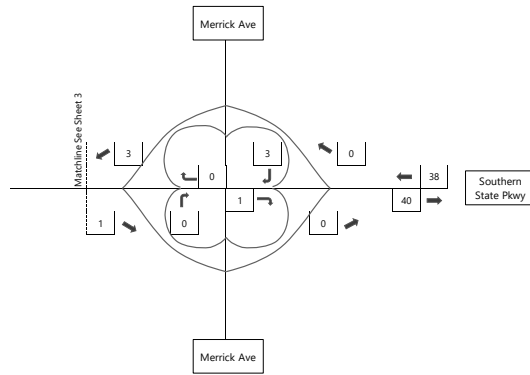
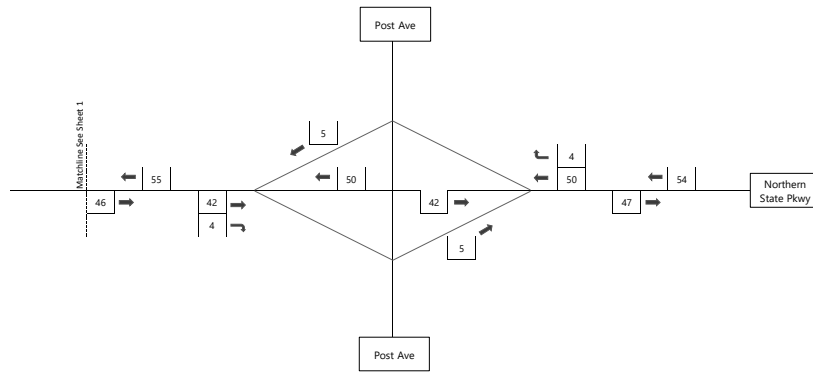

Figure V-B-1, Sheet 4
 Combined OPD Parkway Traffic Volumes
 Weekday AM Peak Hour
 26841.01 - Sands New York Integrated Resort
 Meadowbrook State Parkway



Not to Scale



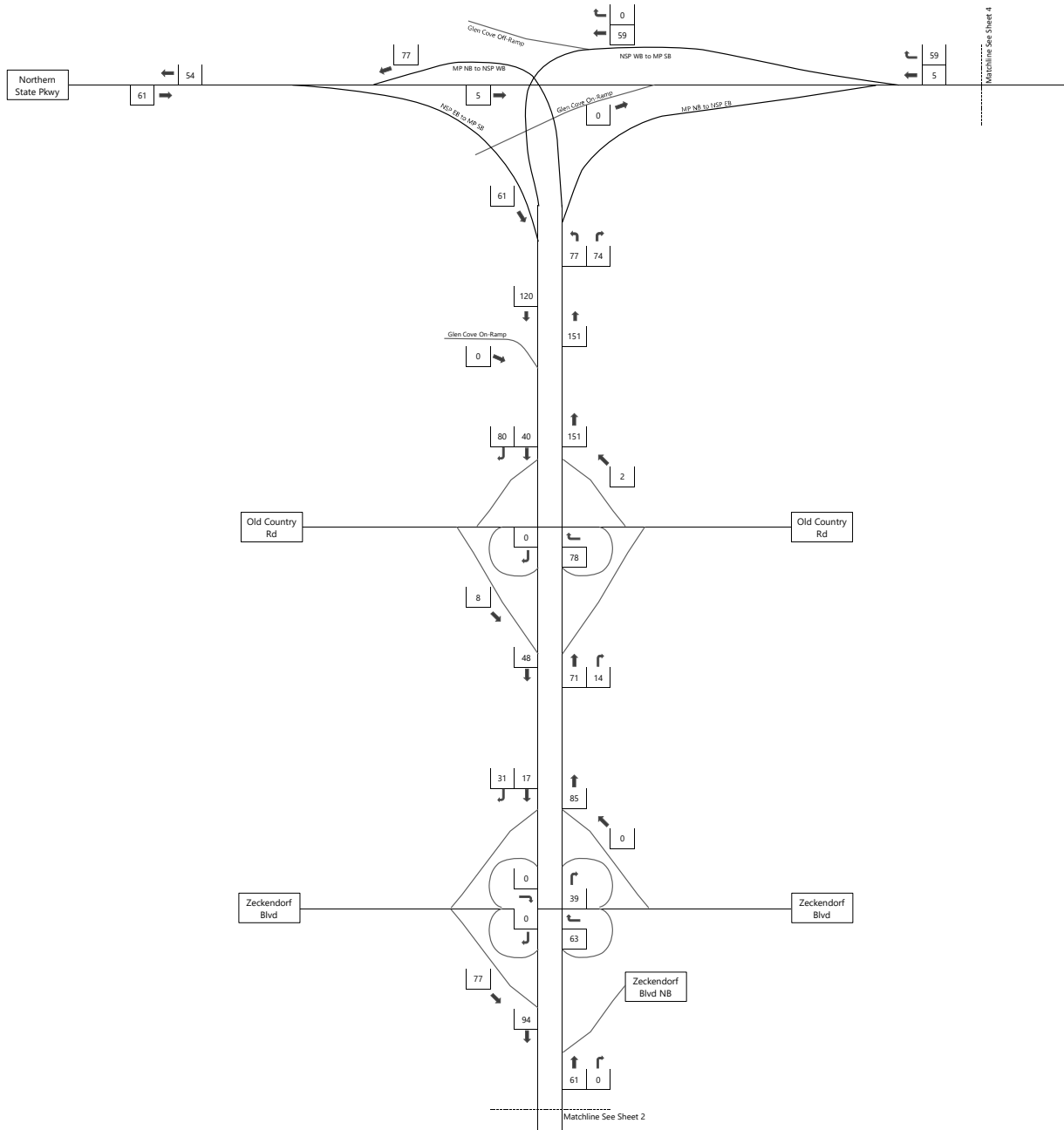

Figure V-B-2, Sheet 1
 Combined OPD Parkway Traffic Volumes
 Weekday PM Peak Hour
 26841.01 - Sands New York Integrated Resort
 Meadowbrook State Parkway



Not to Scale



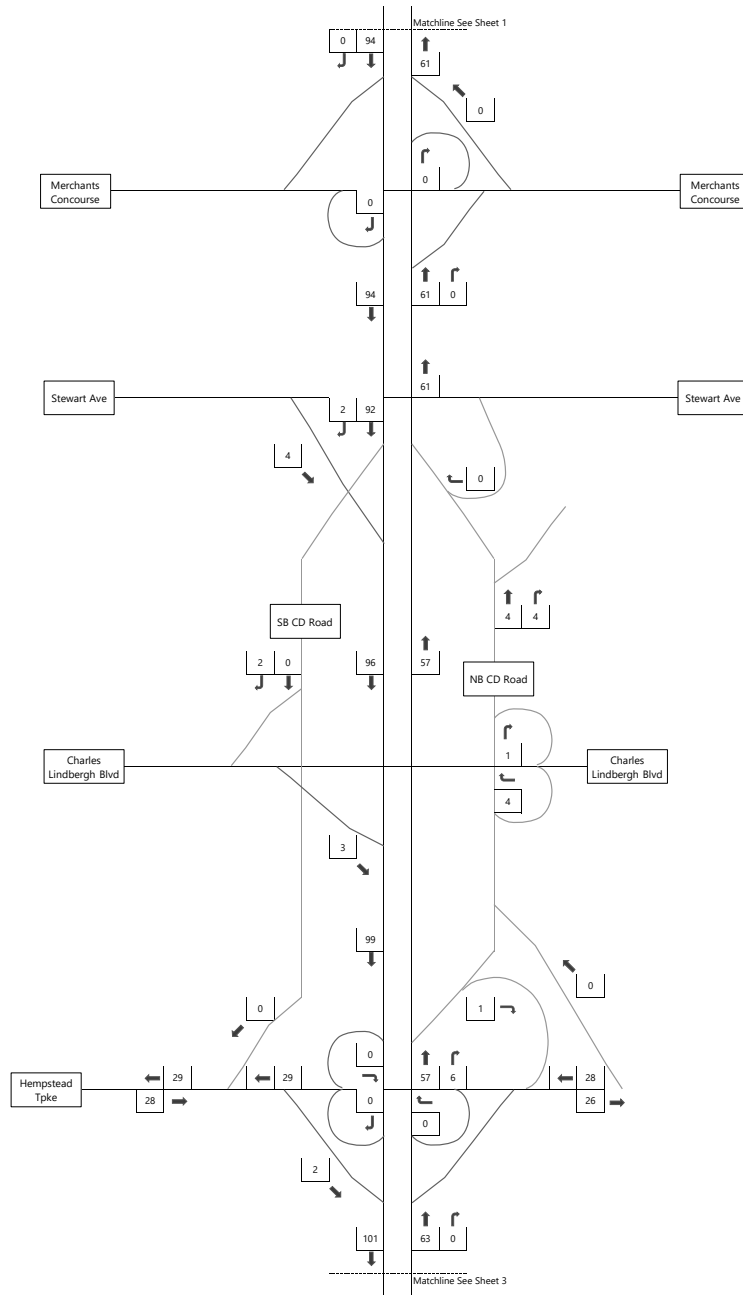

Figure V-B-2, Sheet 2
 Combined OPD Parkway Traffic Volumes
 Weekday PM Peak Hour
 26841.01 - Sands New York Integrated Resort
 Meadowbrook State Parkway



Not to Scale



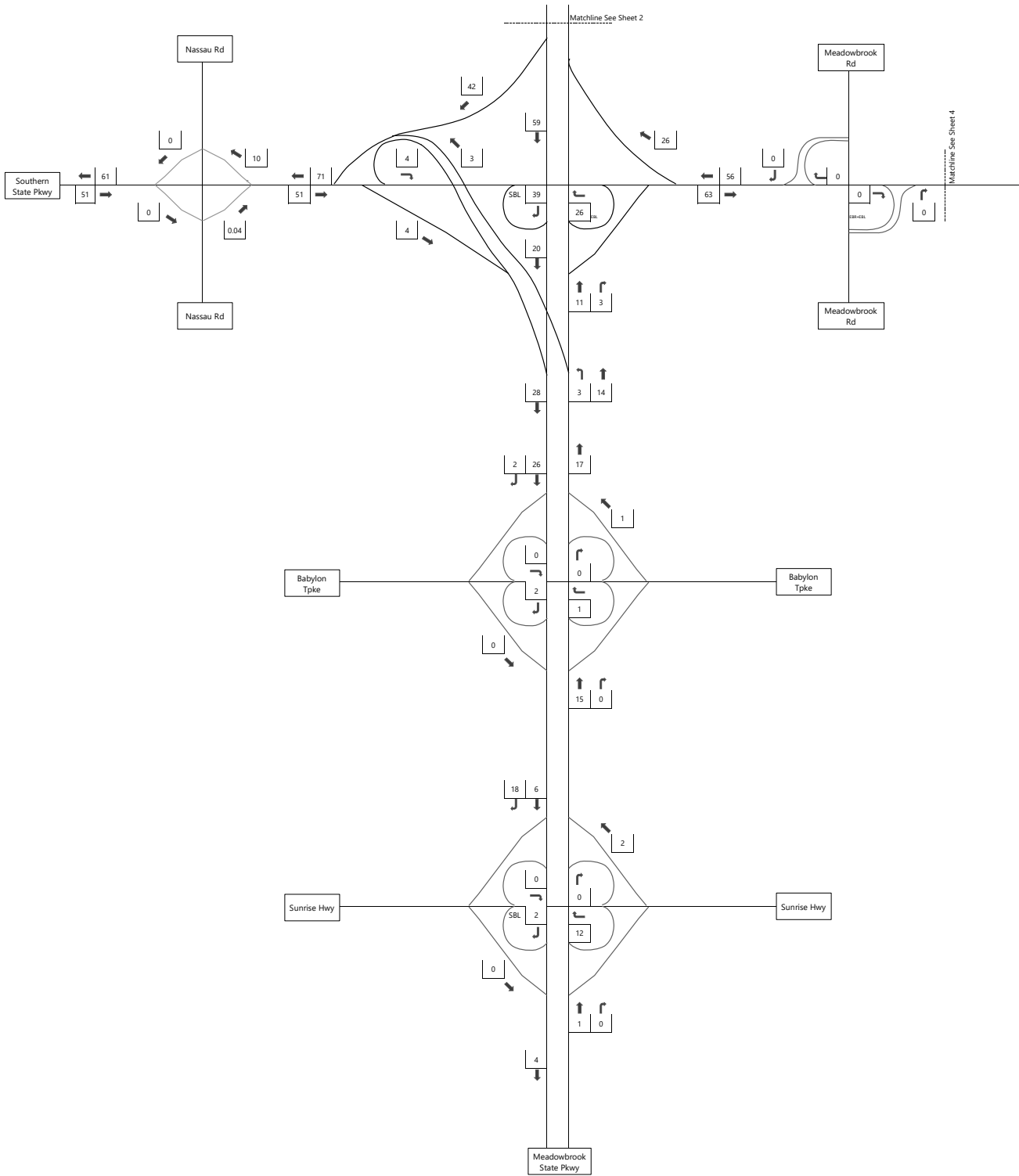

Figure V-B-2, Sheet 3
 Combined OPD Parkway Traffic Volumes
 Weekday PM Peak Hour
 26841.01 - Sands New York Integrated Resort
 Meadowbrook State Parkway



Not to Scale



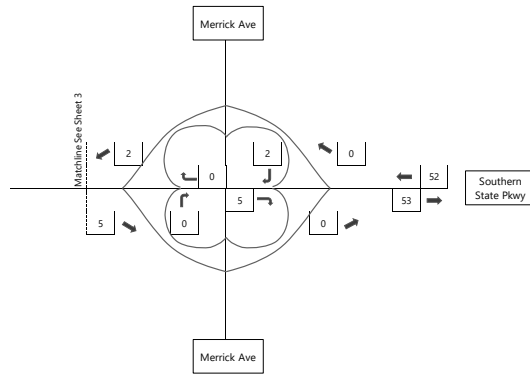
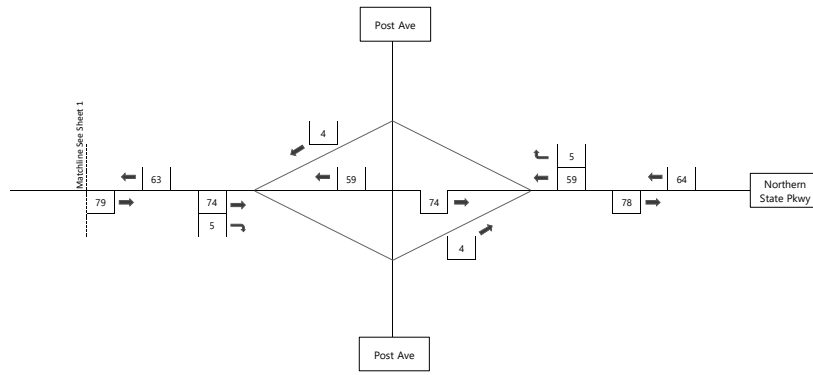

Figure V-B-2, Sheet 4
 Combined OPD Parkway Traffic Volumes
 Weekday PM Peak Hour
 26841.01 - Sands New York Integrated Resort
 Meadowbrook State Parkway



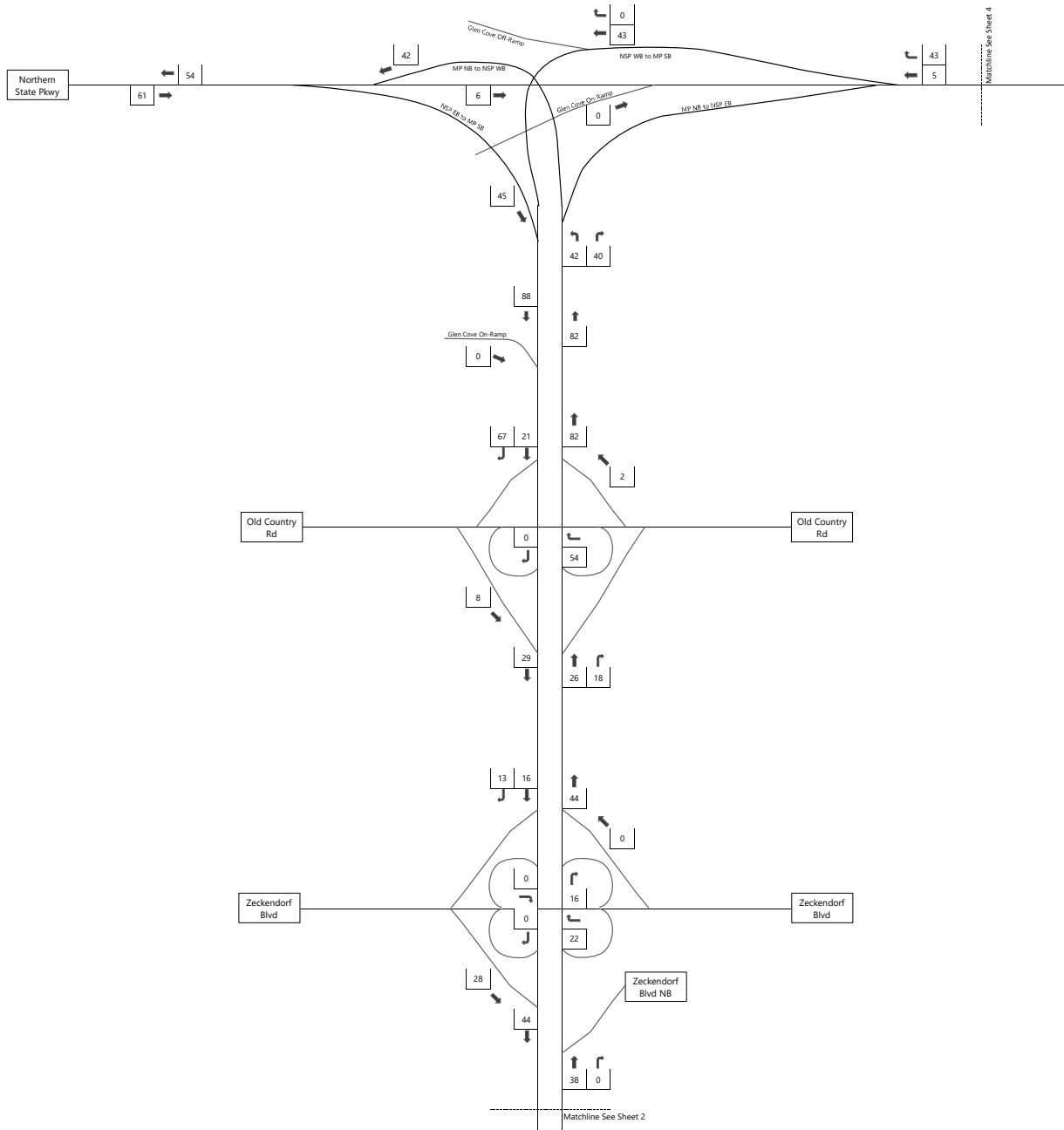

Figure V-B-3, Sheet 1
 Combined OPD Parkway Traffic Volumes
 Friday Evening Peak Hour
 26841.01 - Sands New York Integrated Resort
 Meadowbrook State Parkway



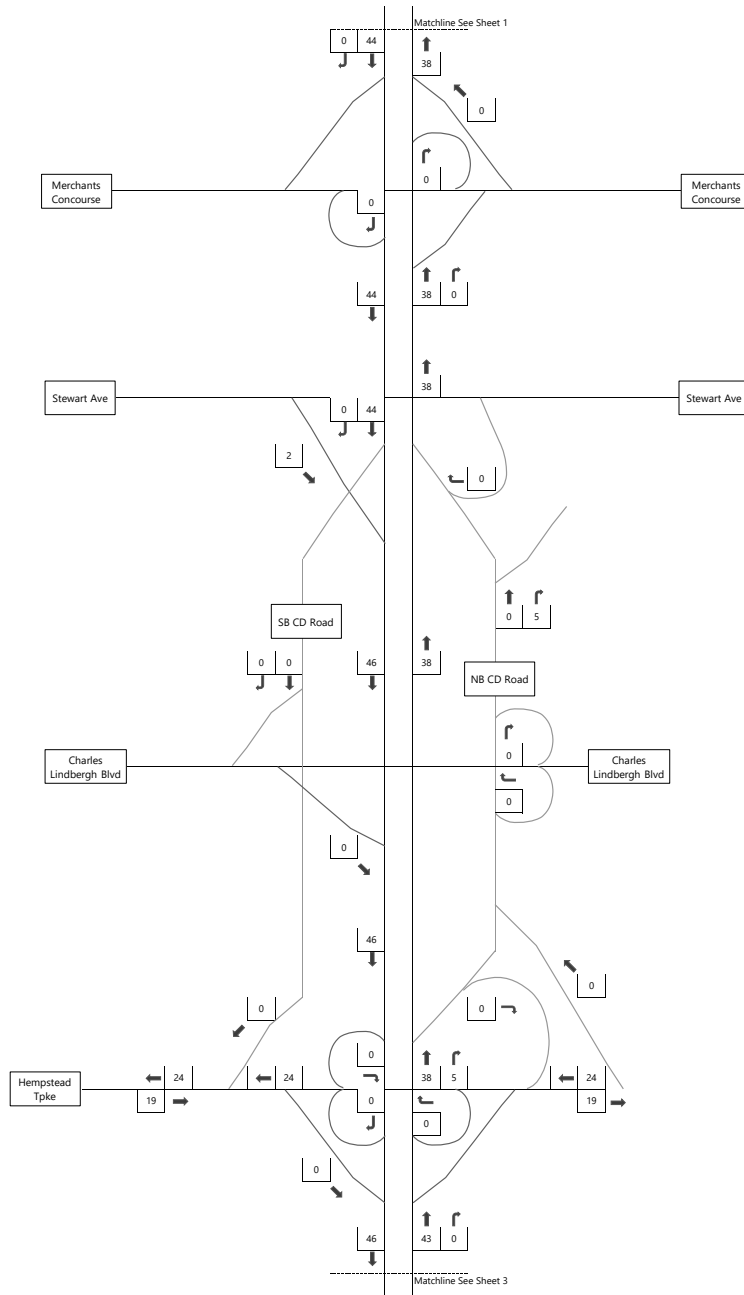

Figure V-B-3, Sheet 2
 Combined OPD Parkway Traffic Volumes
 Friday Evening Peak Hour
 26841.01 - Sands New York Integrated Resort
 Meadowbrook State Parkway



Not to Scale



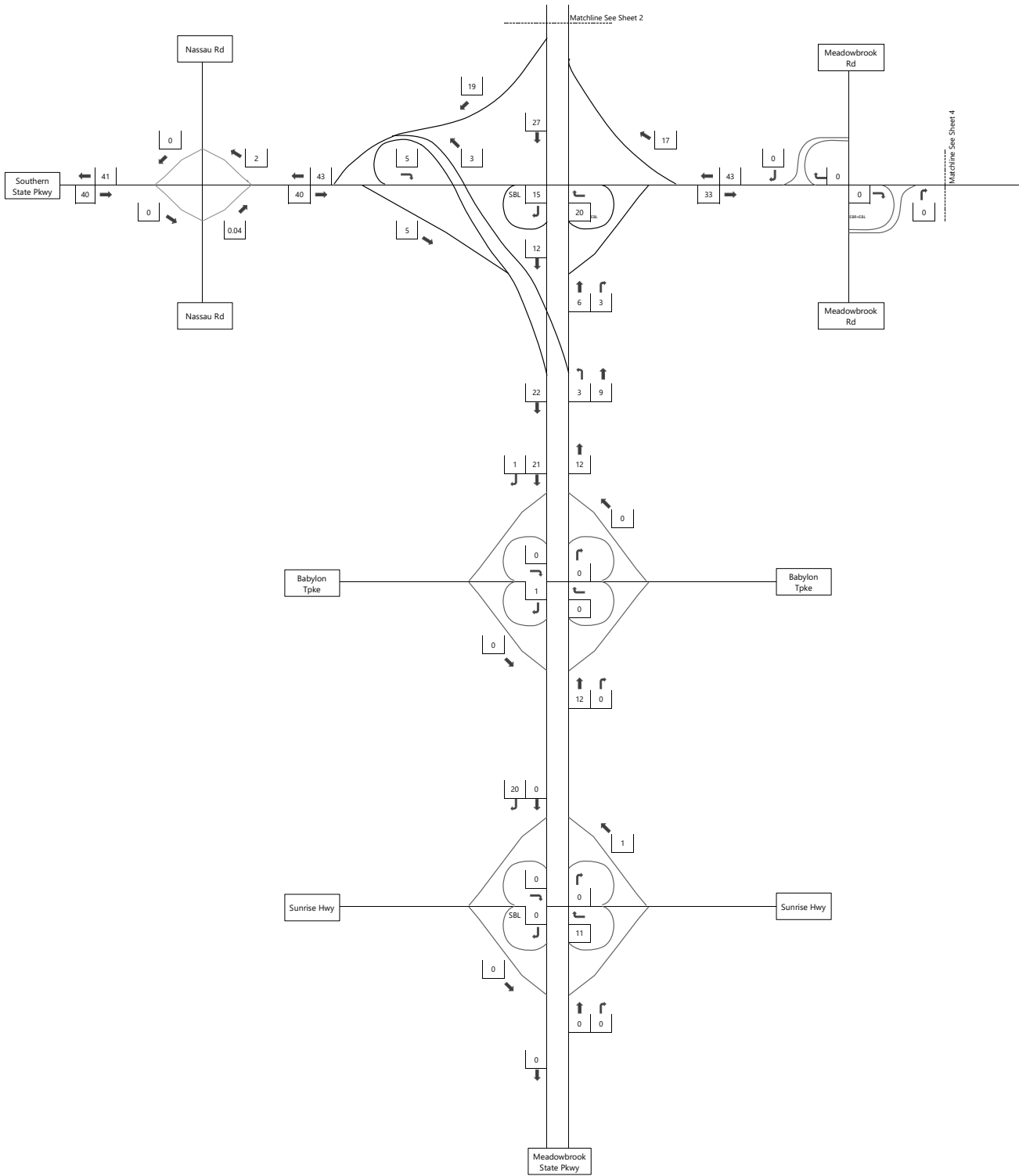

Figure V-B-3, Sheet 3
 Combined OPD Parkway Traffic Volumes
 Friday Evening Peak Hour
 26841.01 - Sands New York Integrated Resort
 Meadowbrook State Parkway



Not to Scale



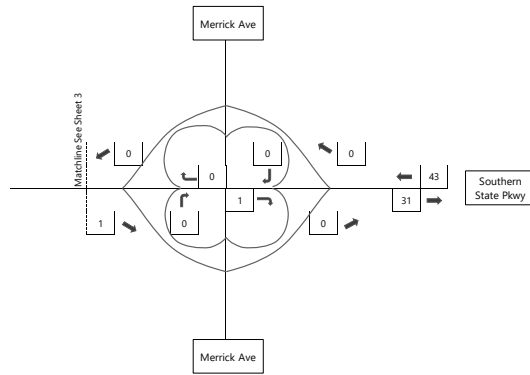
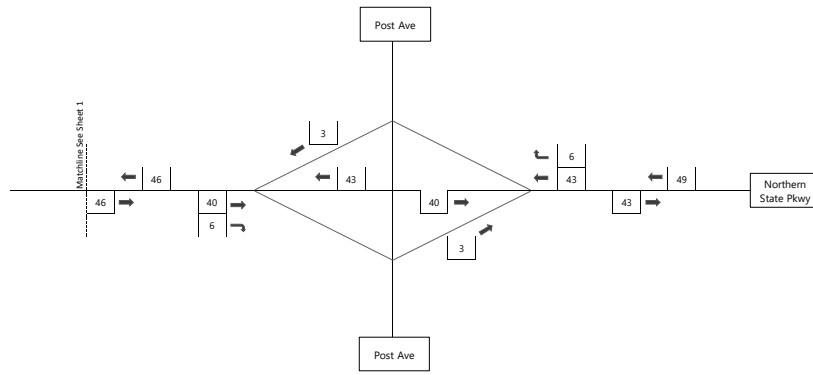

Figure V-B-3, Sheet 4
 Combined OPD Parkway Traffic Volumes
 Friday Evening Peak Hour
 26841.01 - Sands New York Integrated Resort
 Meadowbrook State Parkway



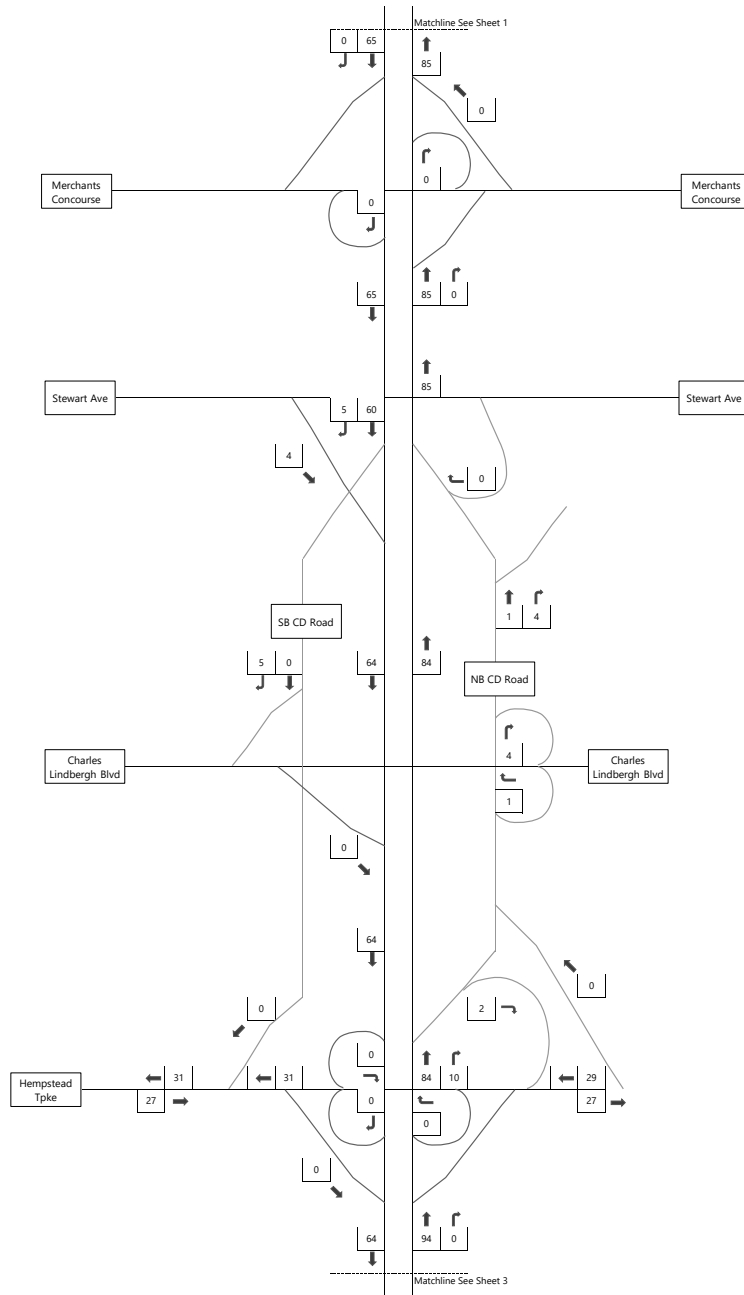

Figure V-B-4, Sheet 2
 Combined OPD Parkway Traffic Volumes
 Saturday Midday Peak Hour
 26841.01 - Sands New York Integrated Resort
 Meadowbrook State Parkway



Not to Scale



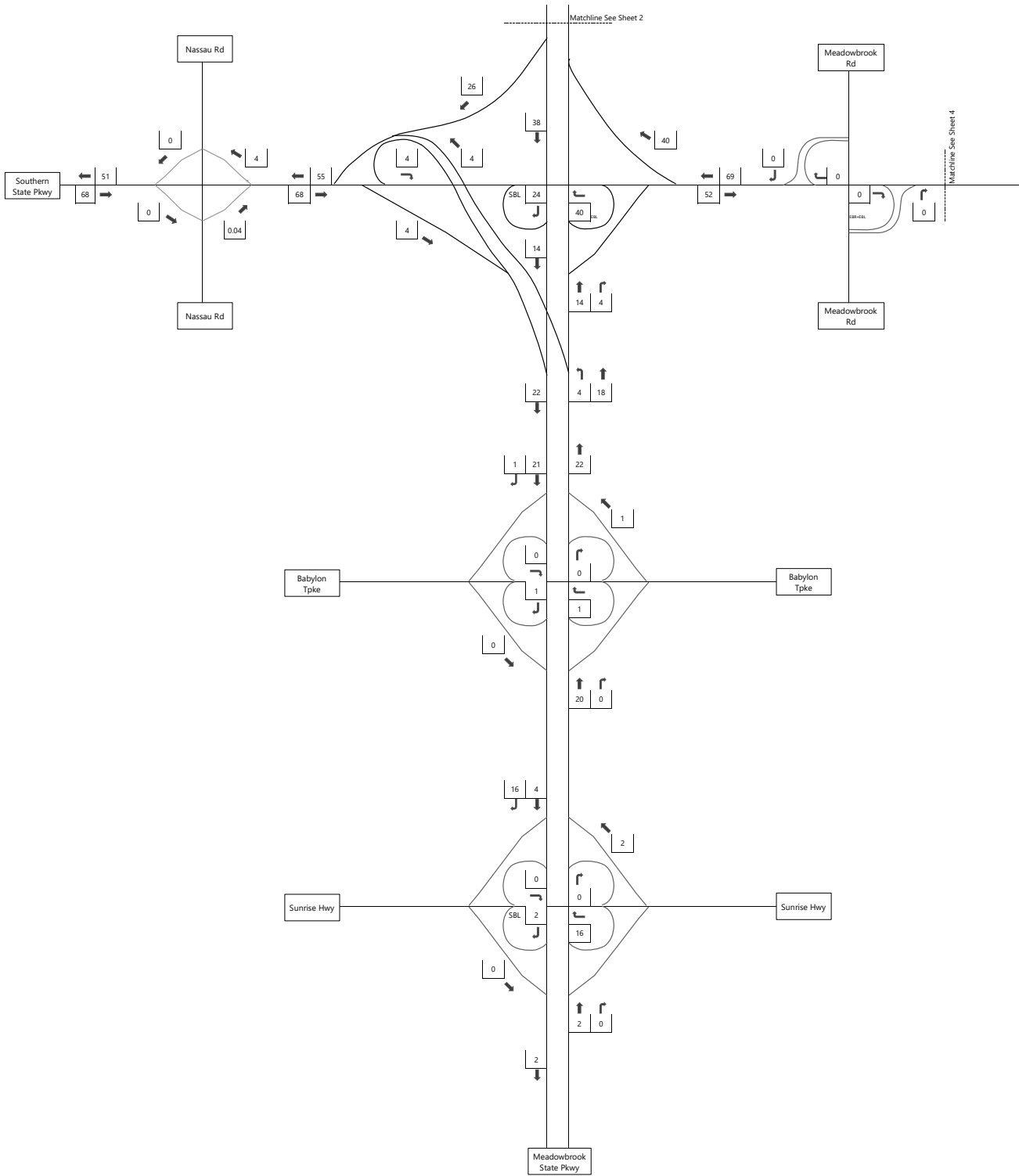

Figure V-B-4, Sheet 3
 Combined OPD Parkway Traffic Volumes
 Saturday Midday Peak Hour
 26841.01 - Sands New York Integrated Resort
 Meadowbrook State Parkway



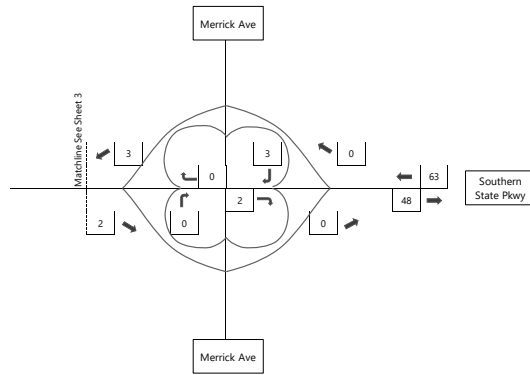
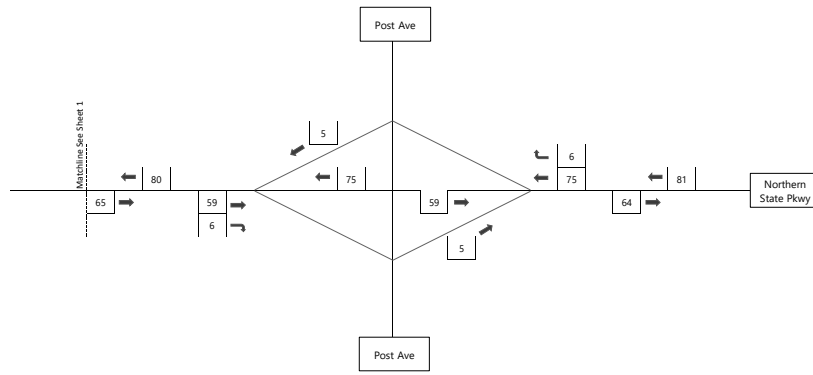

Figure V-B-4, Sheet 4
 Combined OPD Parkway Traffic Volumes
 Saturday Midday Peak Hour
 26841.01 - Sands New York Integrated Resort
 Meadowbrook State Parkway



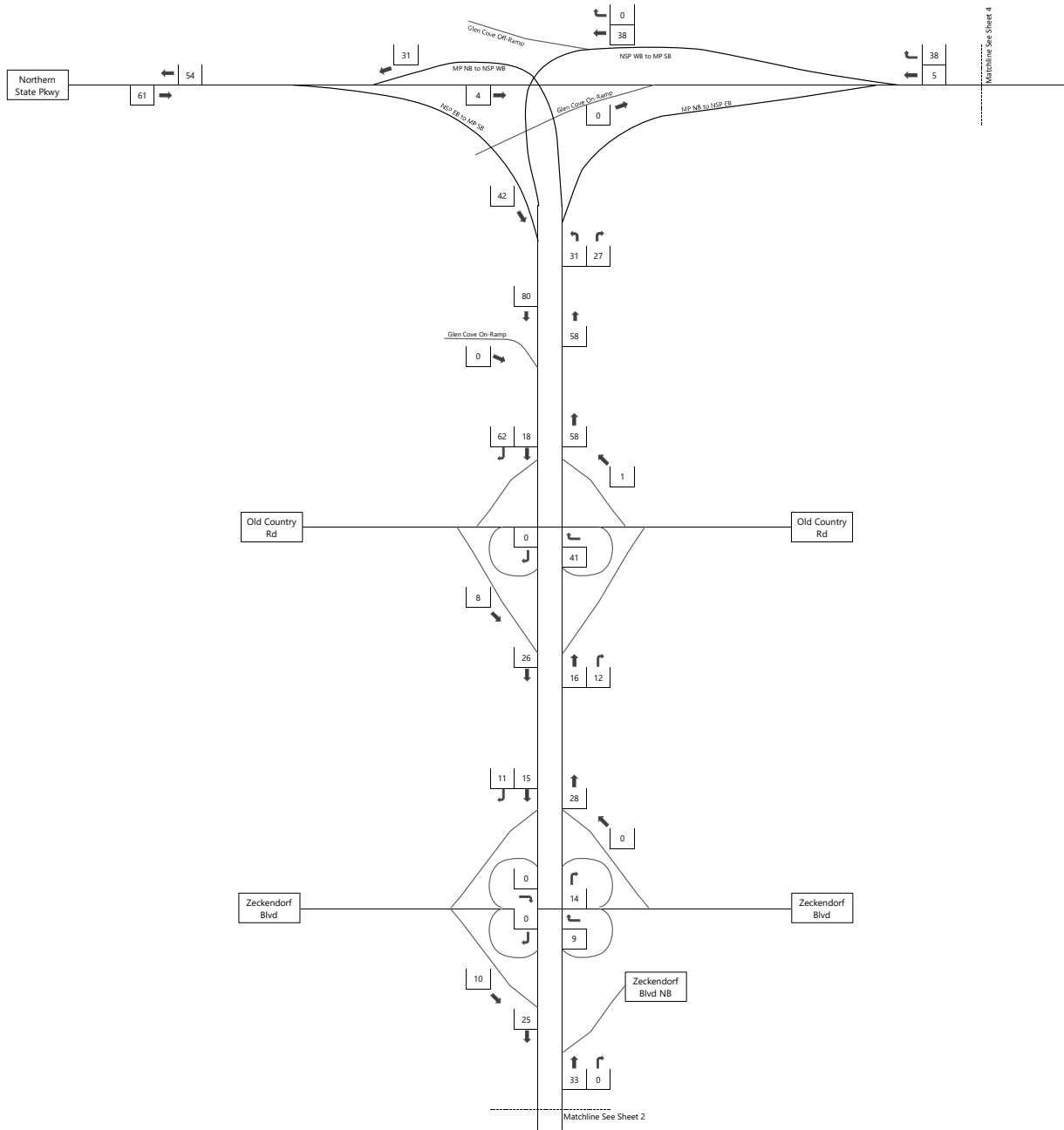

Figure V-B-5, Sheet 1
 Combined OPD Parkway Traffic Volumes
 Saturday Evening Peak Hour
 26841.01 - Sands New York Integrated Resort
 Meadowbrook State Parkway



Not to Scale



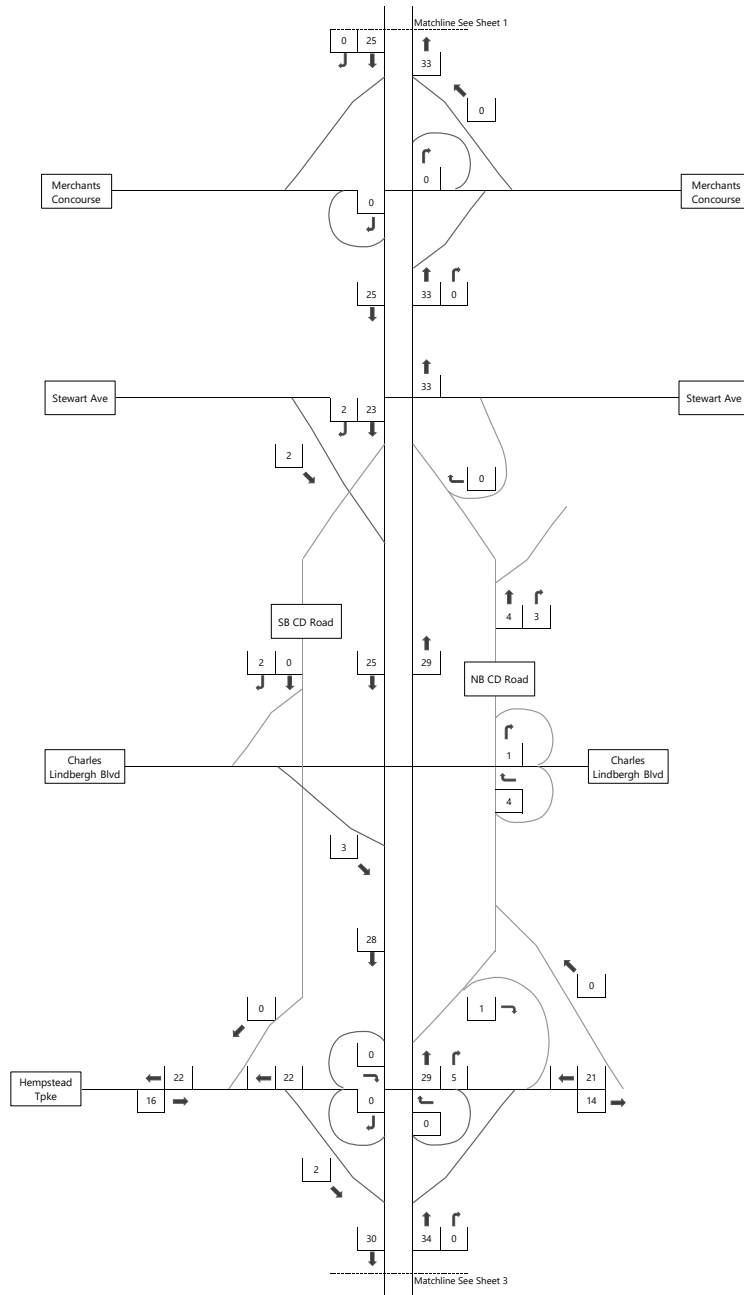

Figure V-B-5, Sheet 2
 Combined OPD Parkway Traffic Volumes
 Saturday Evening Peak Hour
 26841.01 - Sands New York Integrated Resort
 Meadowbrook State Parkway



Not to Scale



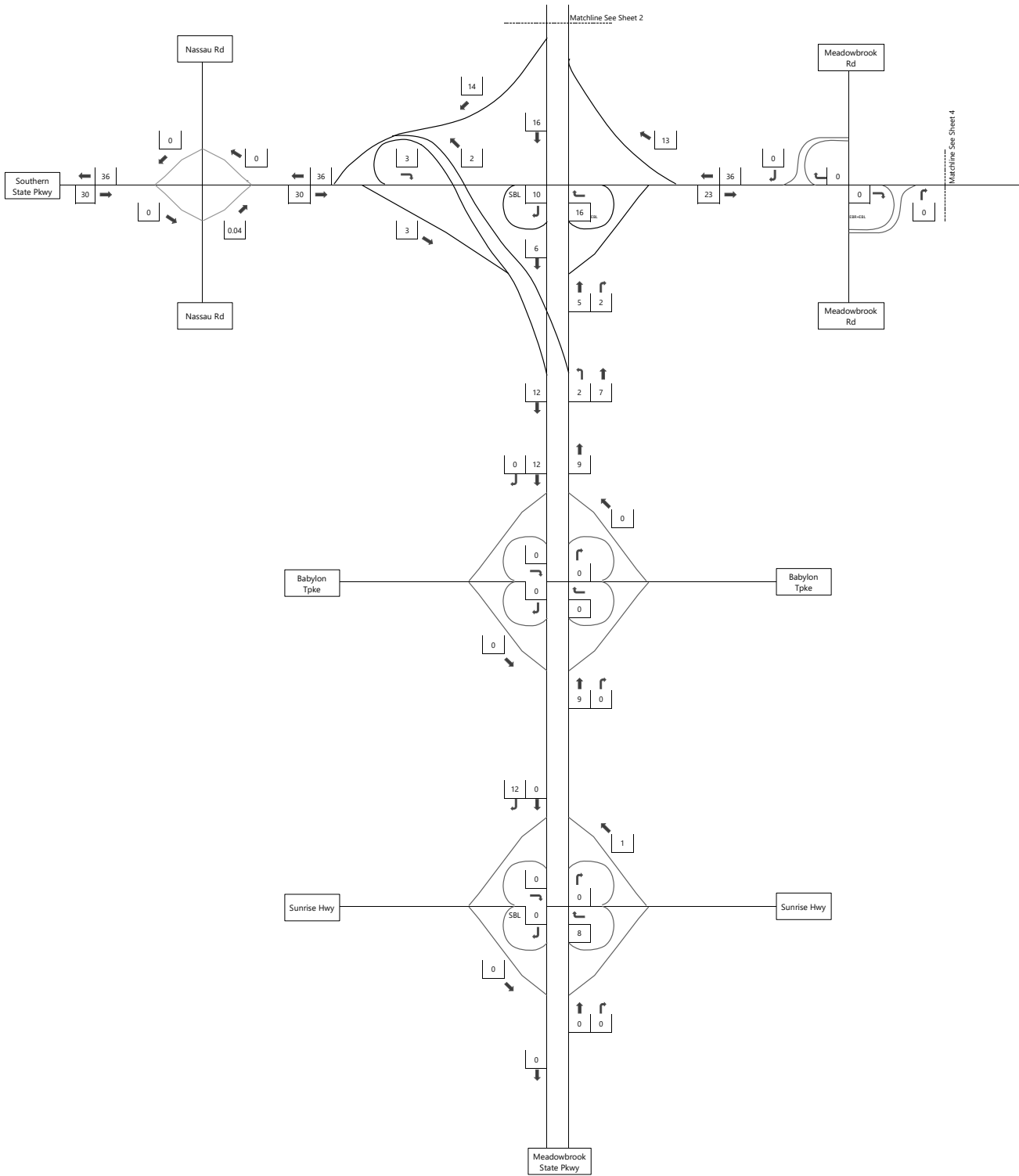

Figure V-B-5, Sheet 3
 Combined OPD Parkway Traffic Volumes
 Saturday Evening Peak Hour
 26841.01 - Sands New York Integrated Resort
 Meadowbrook State Parkway



Not to Scale



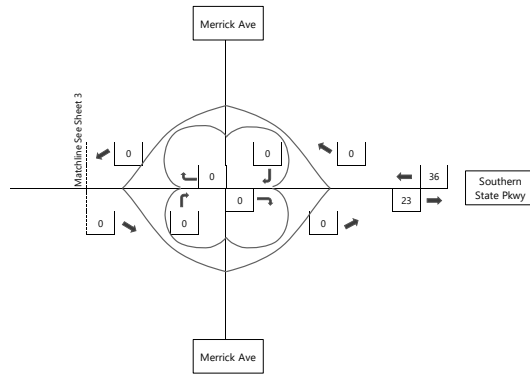
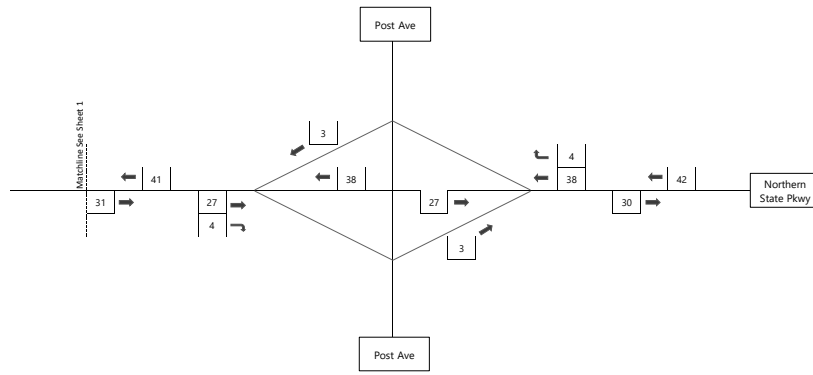

Figure V-B-5, Sheet 4
 Combined OPD Parkway Traffic Volumes
 Saturday Evening Peak Hour
 26841.01 - Sands New York Integrated Resort
 Meadowbrook State Parkway





2030 Full Build

V-C 2030 No-Build Traffic Volumes

**26841.01: Sands Integrated Resort
Traffic Impact Study Attachments
Attachment F – Parkway Peak Hour Traffic Volume Figures**



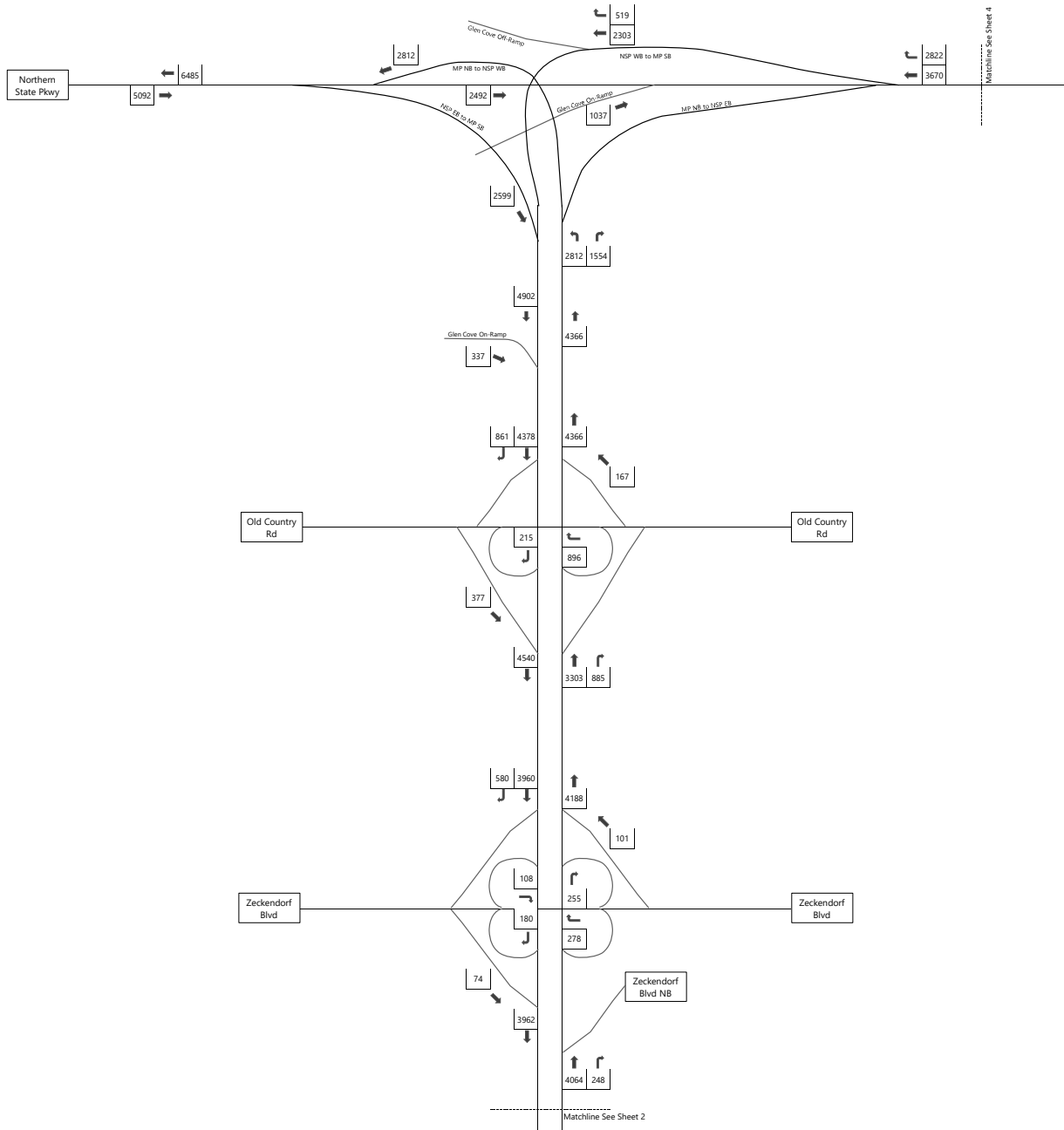

Figure V-C-1, Sheet 1
 2030 No-Build Parkway Traffic Volumes
 Weekday AM Peak Hour
 26841.01 - Sands New York Integrated Resort
 Meadowbrook State Parkway



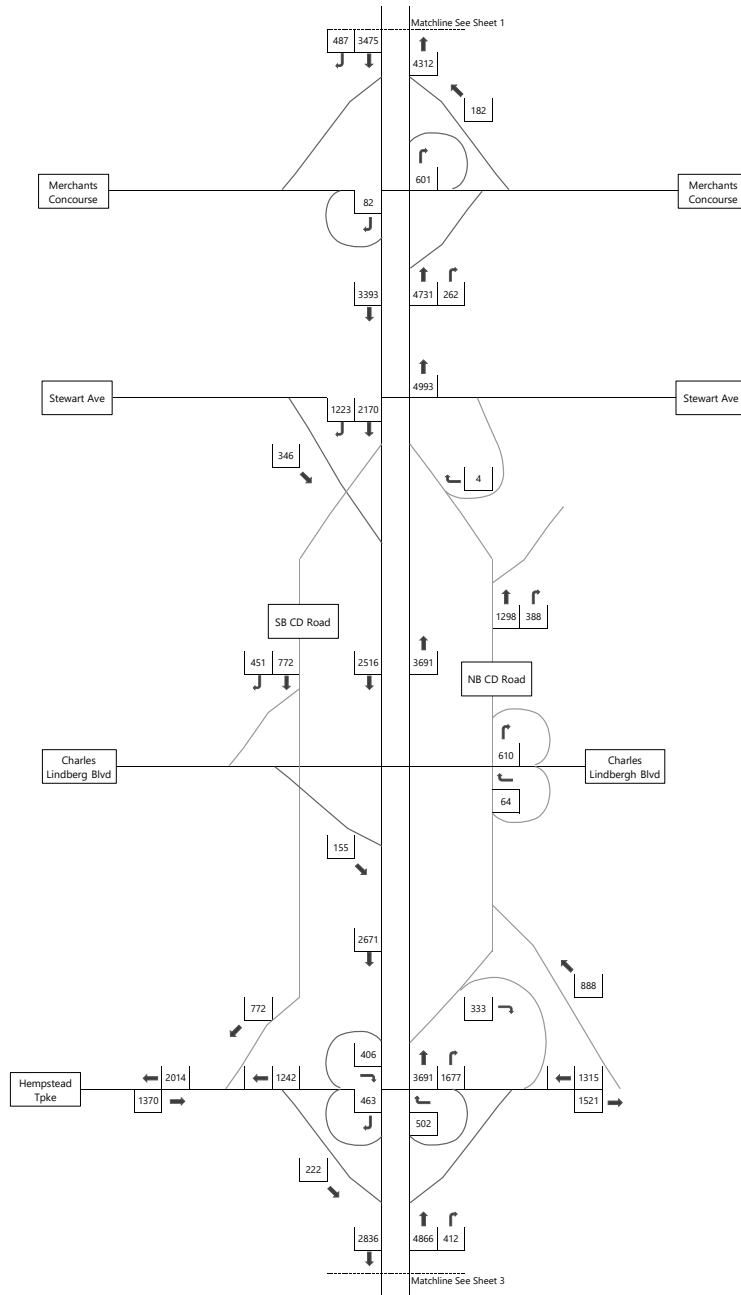

Figure V-C-1, Sheet 2
 2030 No-Build Parkway Traffic Volumes
 Weekday AM Peak Hour
 26841.01 - Sands New York Integrated Resort
 Meadowbrook State Parkway



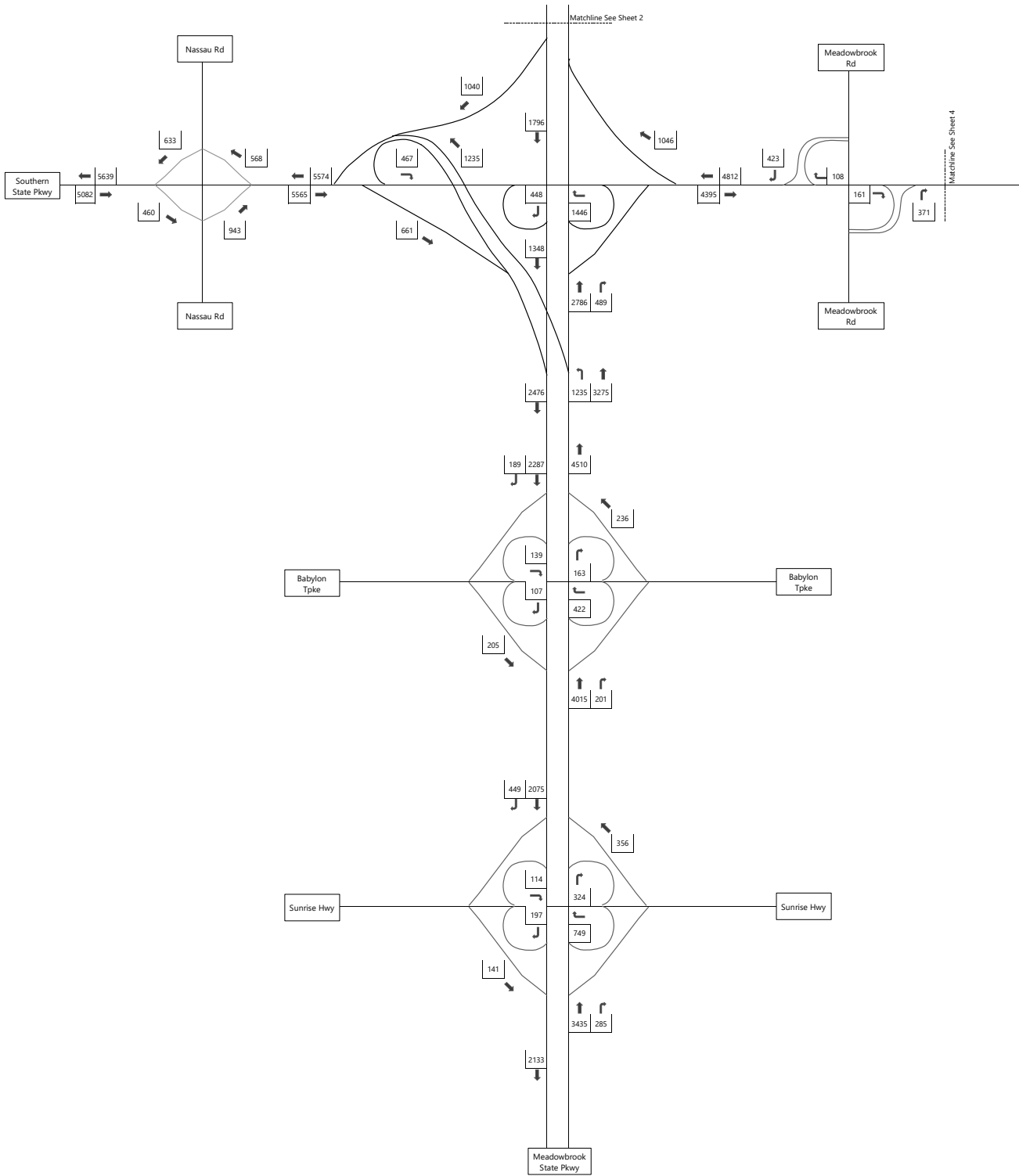

Figure V-C-1, Sheet 3
 2030 No-Build Parkway Traffic Volumes
 Weekday AM Peak Hour
 26841.01 - Sands New York Integrated Resort
 Meadowbrook State Parkway



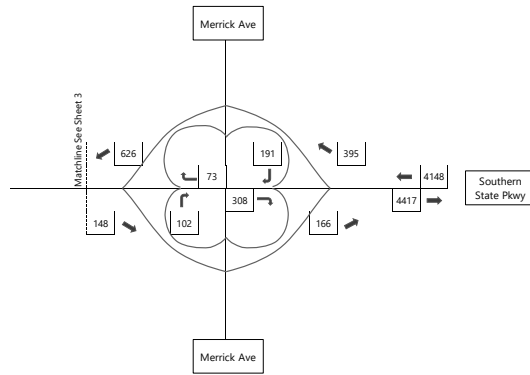
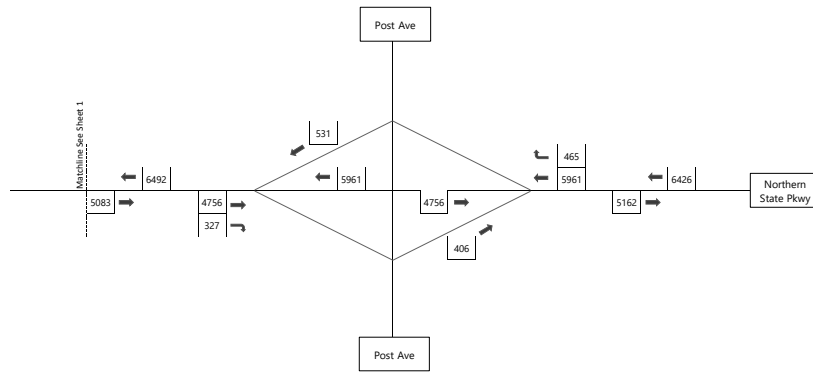

Figure V-C-1, Sheet 4
 2030 No-Build Parkway Traffic Volumes
 Weekday AM Peak Hour
 26841.01 - Sands New York Integrated Resort
 Meadowbrook State Parkway



Not to Scale



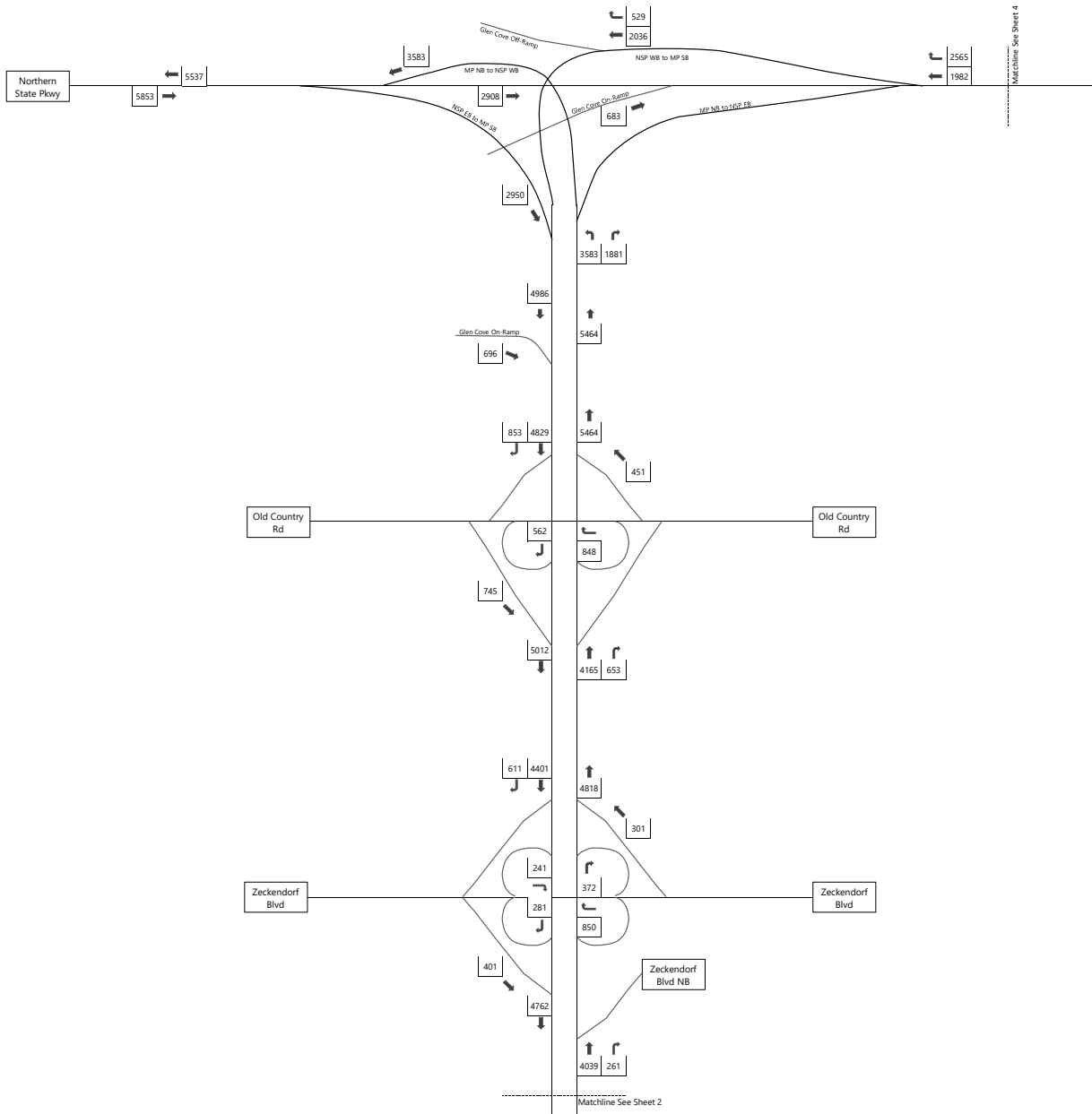

Figure V-C-2, Sheet 1
 2030 No-Build Parkway Traffic Volumes
 Weekday PM Peak Hour
 26841.01 - Sands New York Integrated Resort
 Meadowbrook State Parkway



Not to Scale



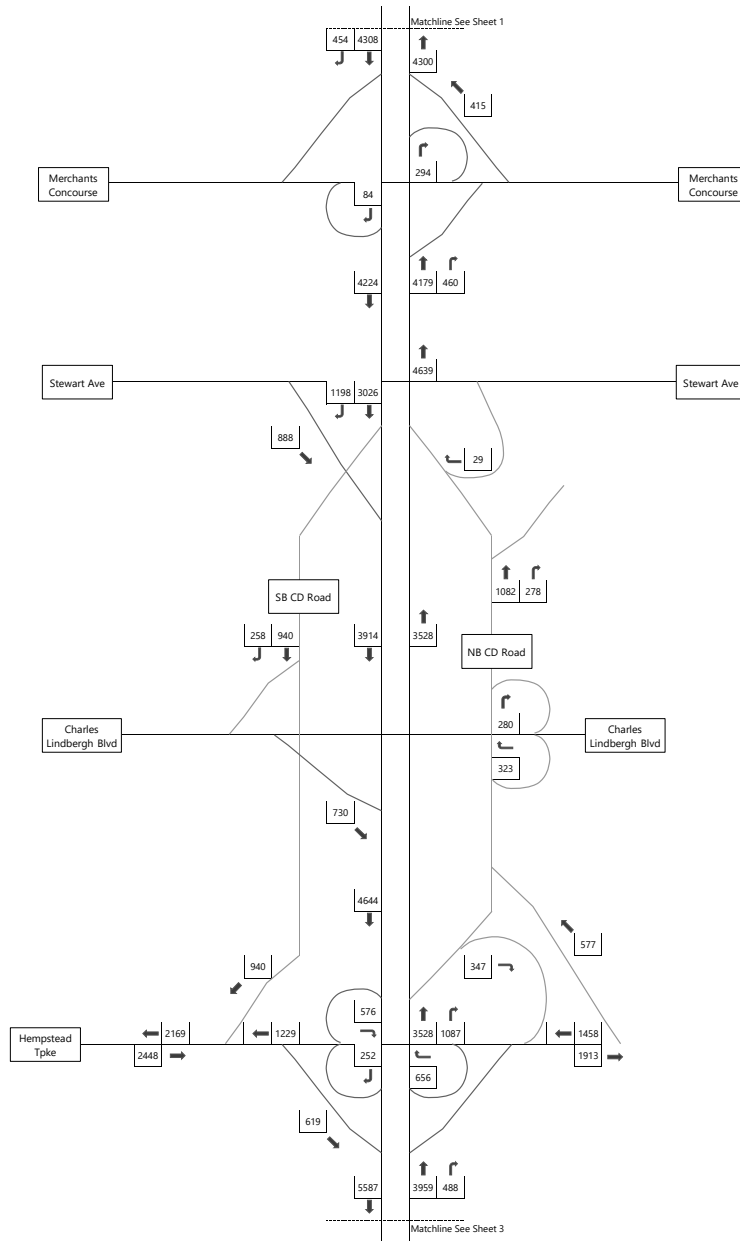

Figure V-C-2, Sheet 2
 2030 No-Build Parkway Traffic Volumes
 Weekday PM Peak Hour
 26841.01 - Sands New York Integrated Resort
 Meadowbrook State Parkway



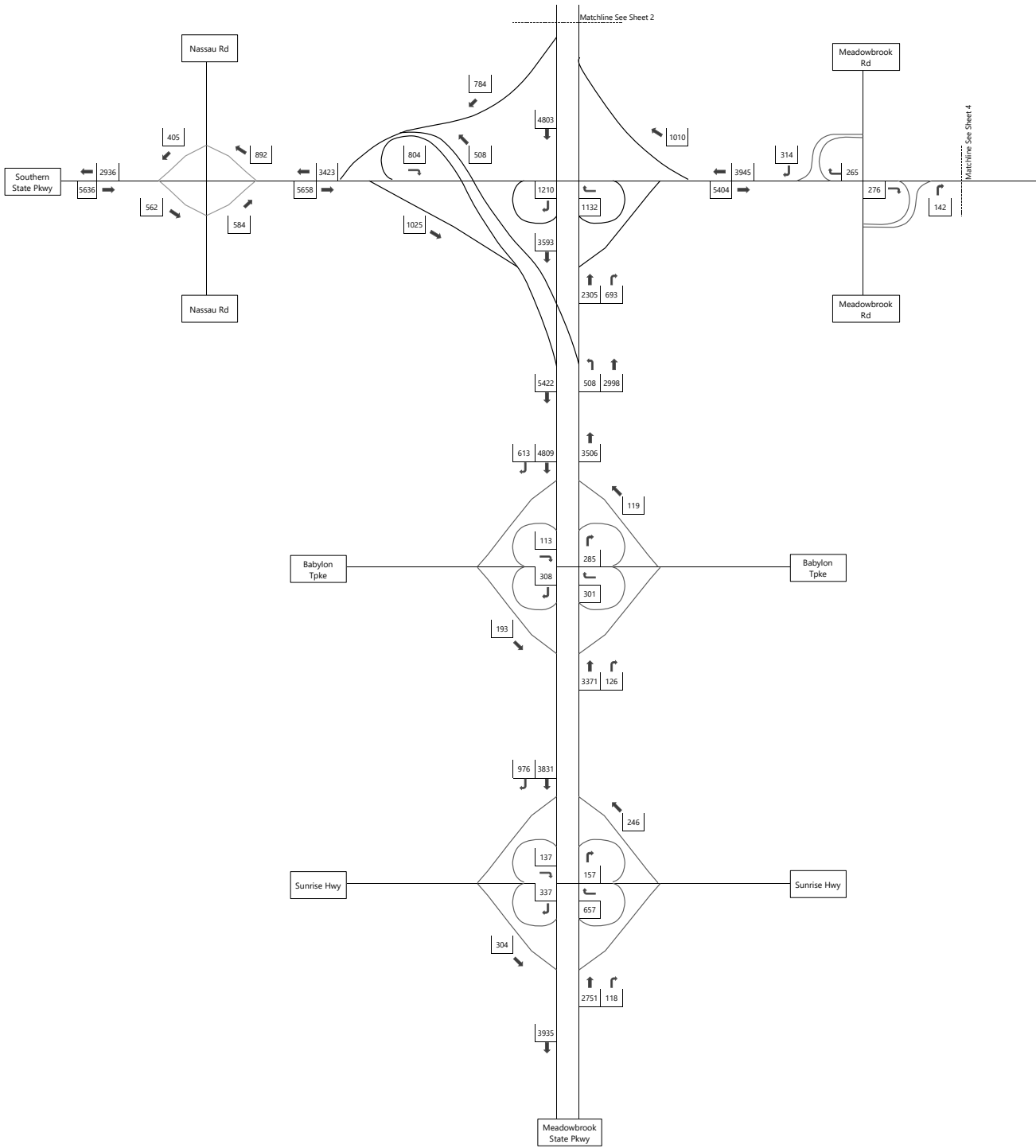

Figure V-C-2, Sheet 3
 2030 No-Build Parkway Traffic Volumes
 Weekday PM Peak Hour
 26841.01 - Sands New York Integrated Resort
 Meadowbrook State Parkway



Not to Scale



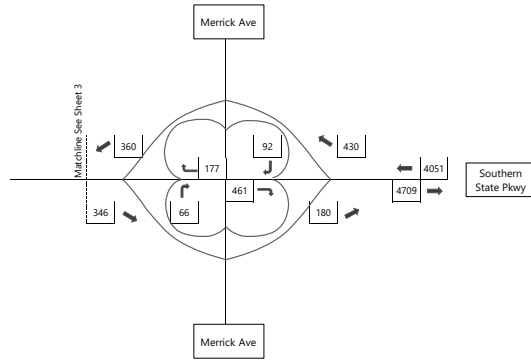
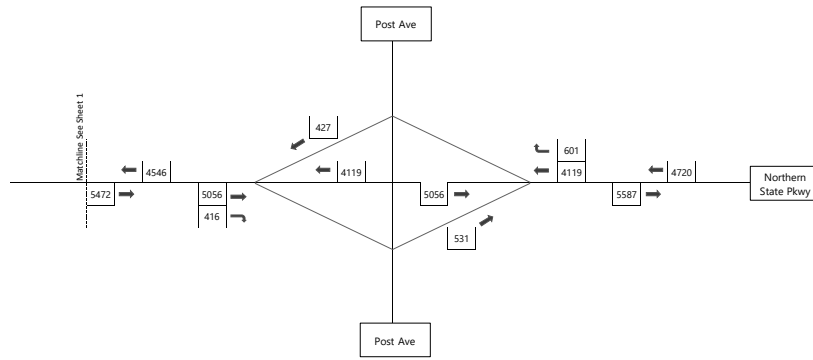

Figure V-C-2, Sheet 4
 2030 No-Build Parkway Traffic Volumes
 Weekday PM Peak Hour
 26841.01 - Sands New York Integrated Resort
 Meadowbrook State Parkway



Not to Scale



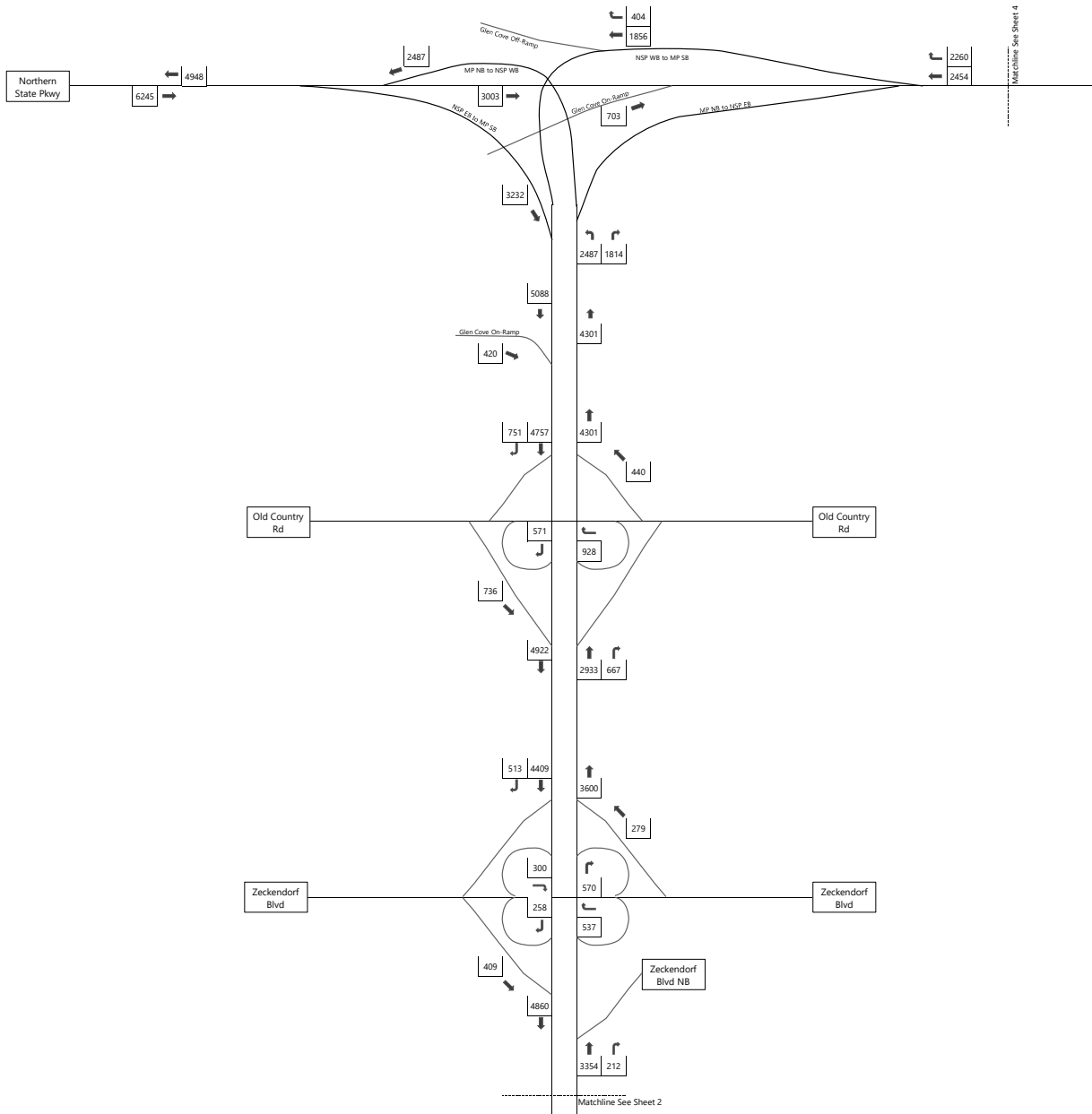

Figure V-C-3, Sheet 1
 2030 No-Build Parkway Traffic Volumes
 Friday Evening Peak Hour
 26841.01 - Sands New York Integrated Resort
 Meadowbrook State Parkway



Not to Scale



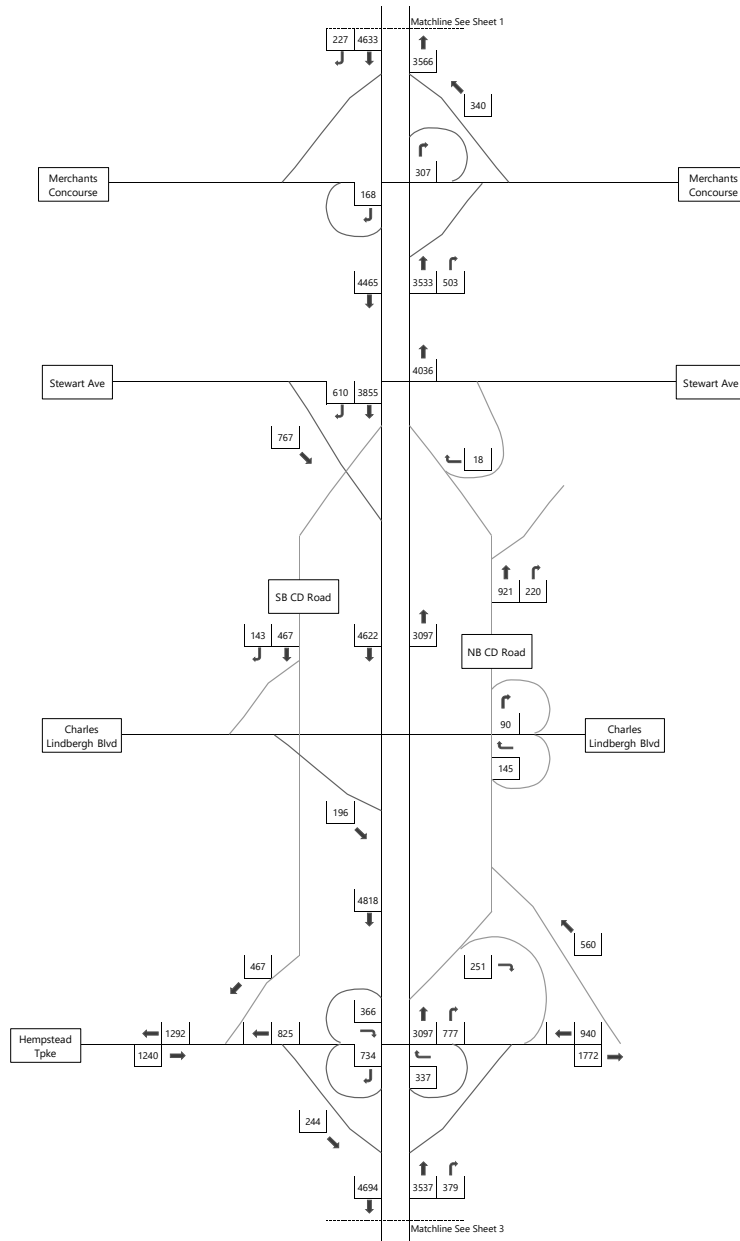

Figure V-C-3, Sheet 2
 2030 No-Build Parkway Traffic Volumes
 Friday Evening Peak Hour
 26841.01 - Sands New York Integrated Resort
 Meadowbrook State Parkway



Not to Scale



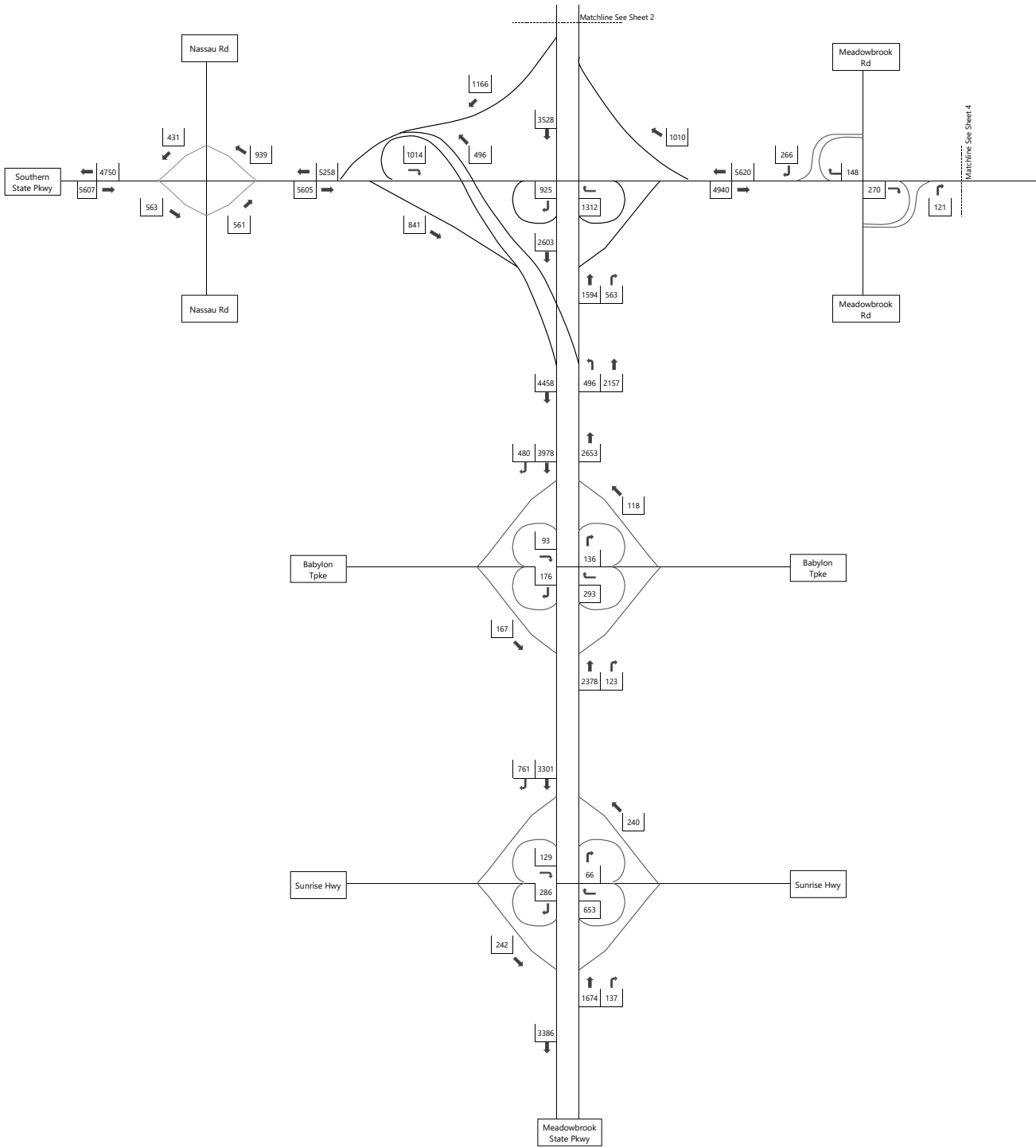

Figure V-C-3, Sheet 3
 2030 No-Build Parkway Traffic Volumes
 Friday Evening Peak Hour
 26841.01 - Sands New York Integrated Resort
 Meadowbrook State Parkway



Not to Scale



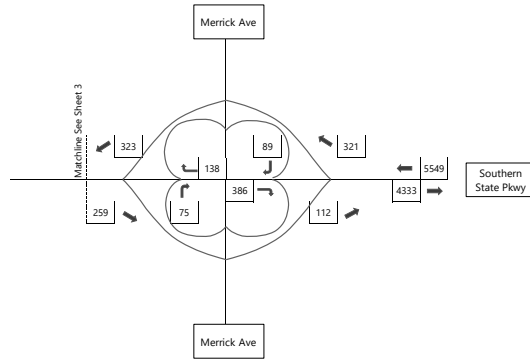
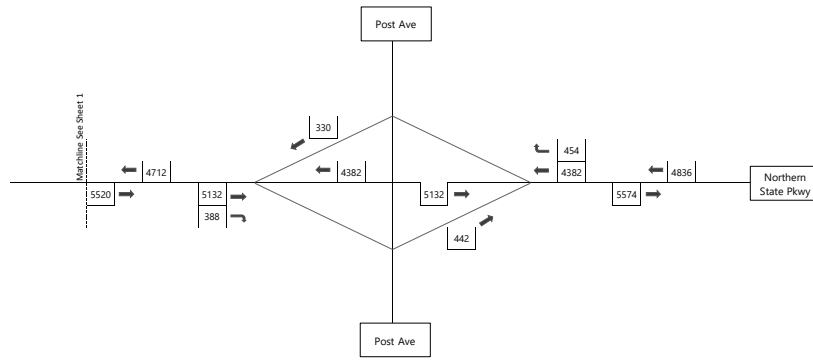

Figure V-C-3, Sheet 4
 2030 No-Build Parkway Traffic Volumes
 Friday Evening Peak Hour
 26841.01 - Sands New York Integrated Resort
 Meadowbrook State Parkway



Not to Scale



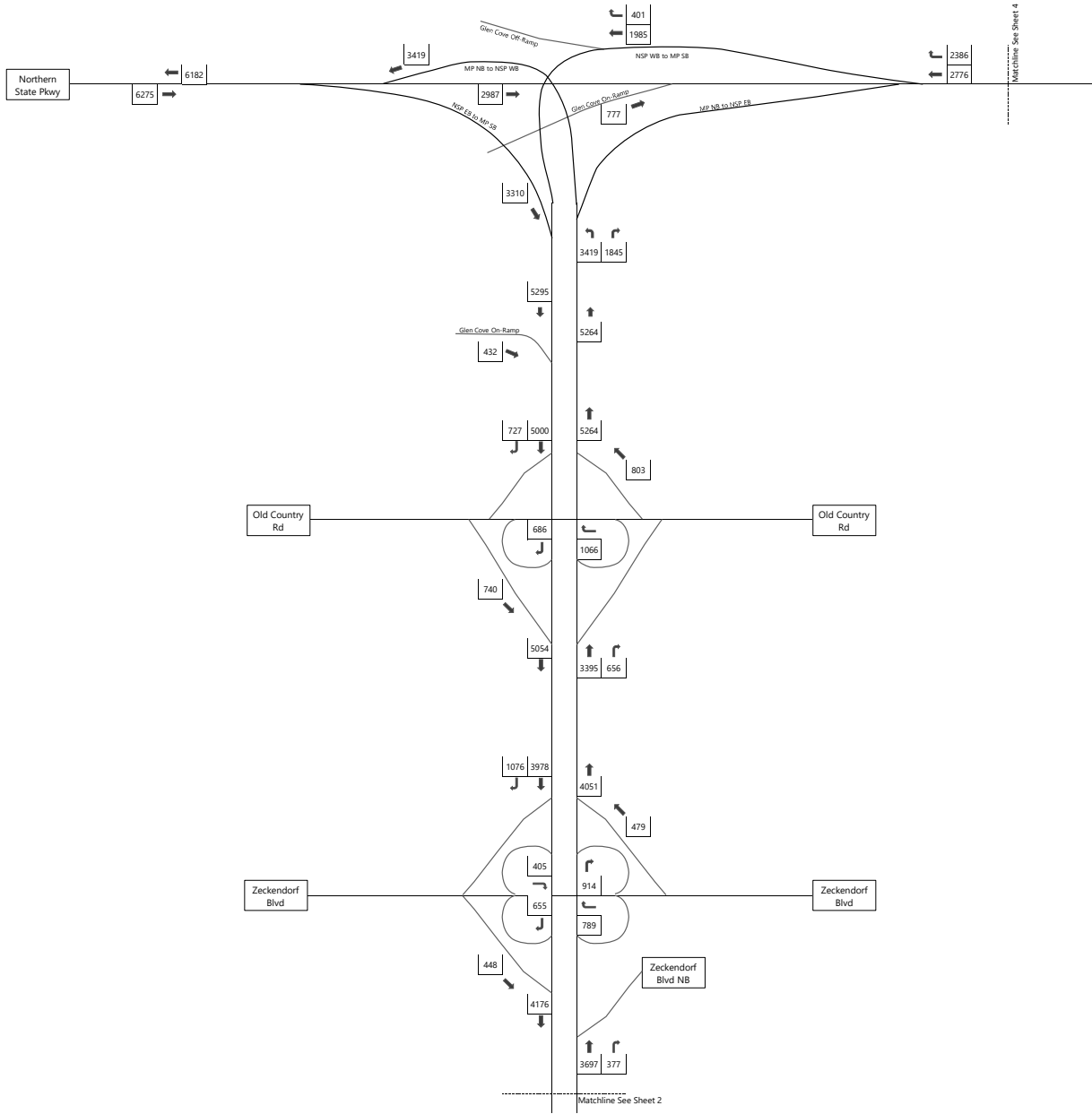

Figure V-C-4, Sheet 1
 2030 No-Build Parkway Traffic Volumes
 Saturday Midday Peak Hour
 26841.01 - Sands New York Integrated Resort
 Meadowbrook State Parkway



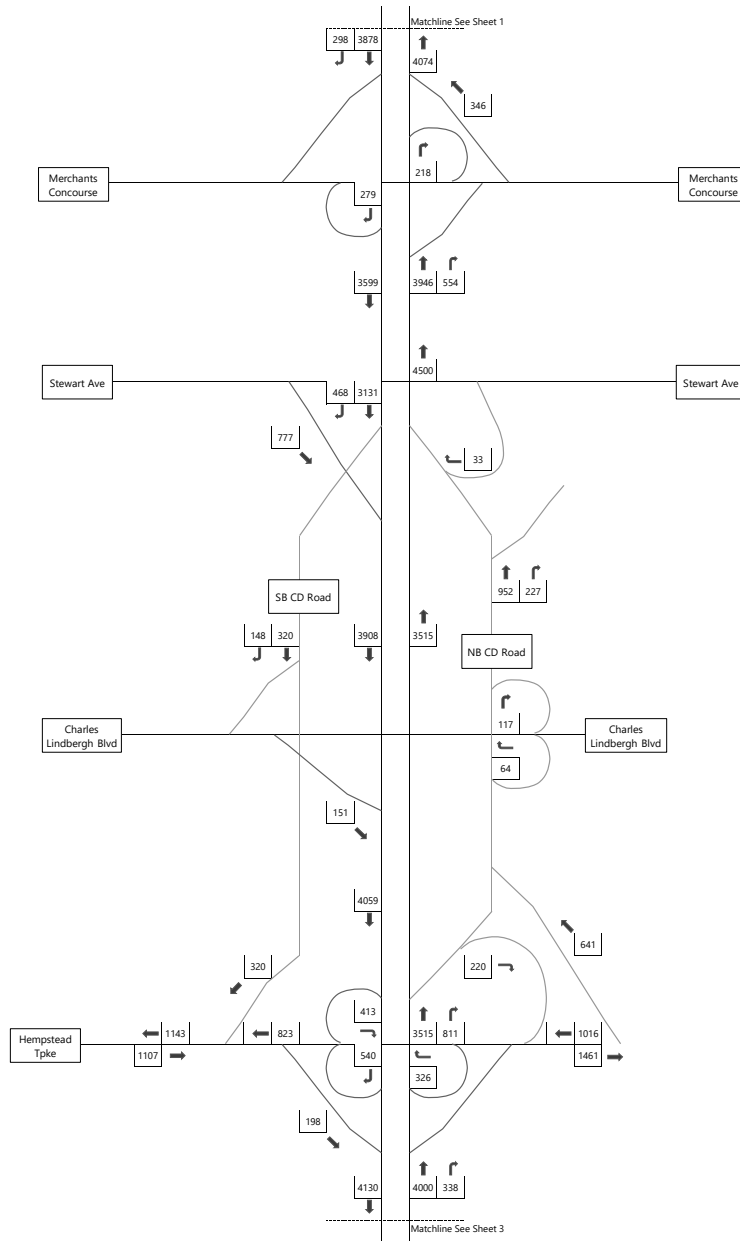

Figure V-C-4, Sheet 2
 2030 No-Build Parkway Traffic Volumes
 Saturday Midday Peak Hour
 26841.01 - Sands New York Integrated Resort
 Meadowbrook State Parkway



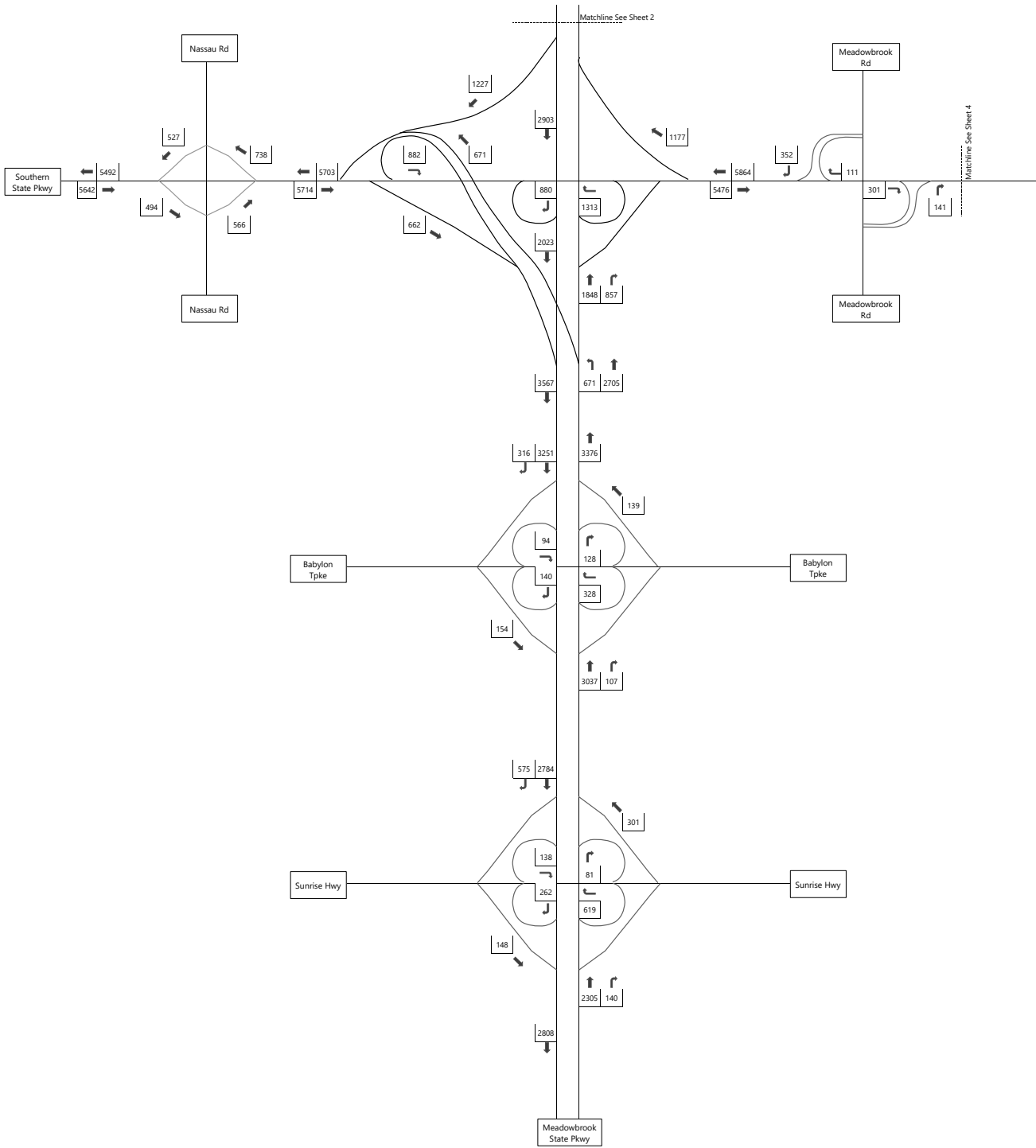

Figure V-C-4, Sheet 3
 2030 No-Build Parkway Traffic Volumes
 Saturday Midday Peak Hour
 26841.01 - Sands New York Integrated Resort
 Meadowbrook State Parkway



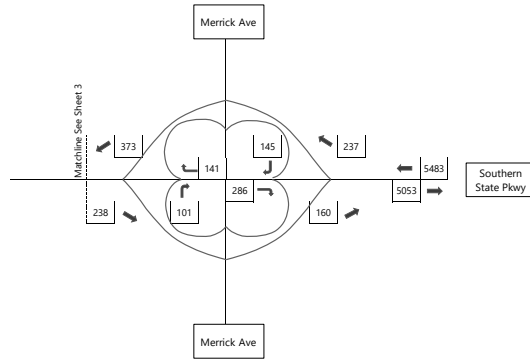
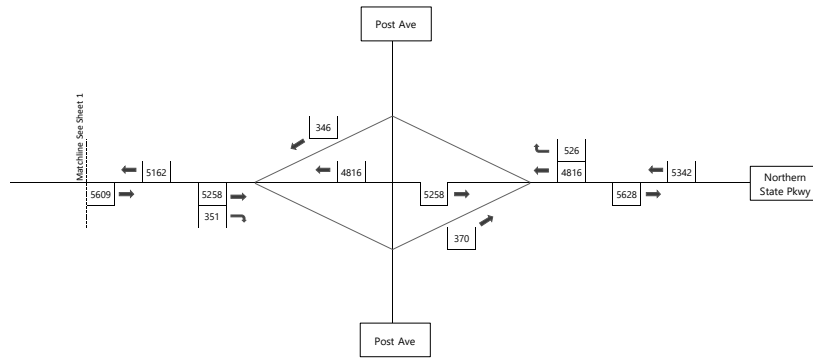

Figure V-C-4, Sheet 4
 2030 No-Build Parkway Traffic Volumes
 Saturday Midday Peak Hour
 26841.01 - Sands New York Integrated Resort
 Meadowbrook State Parkway



Not to Scale



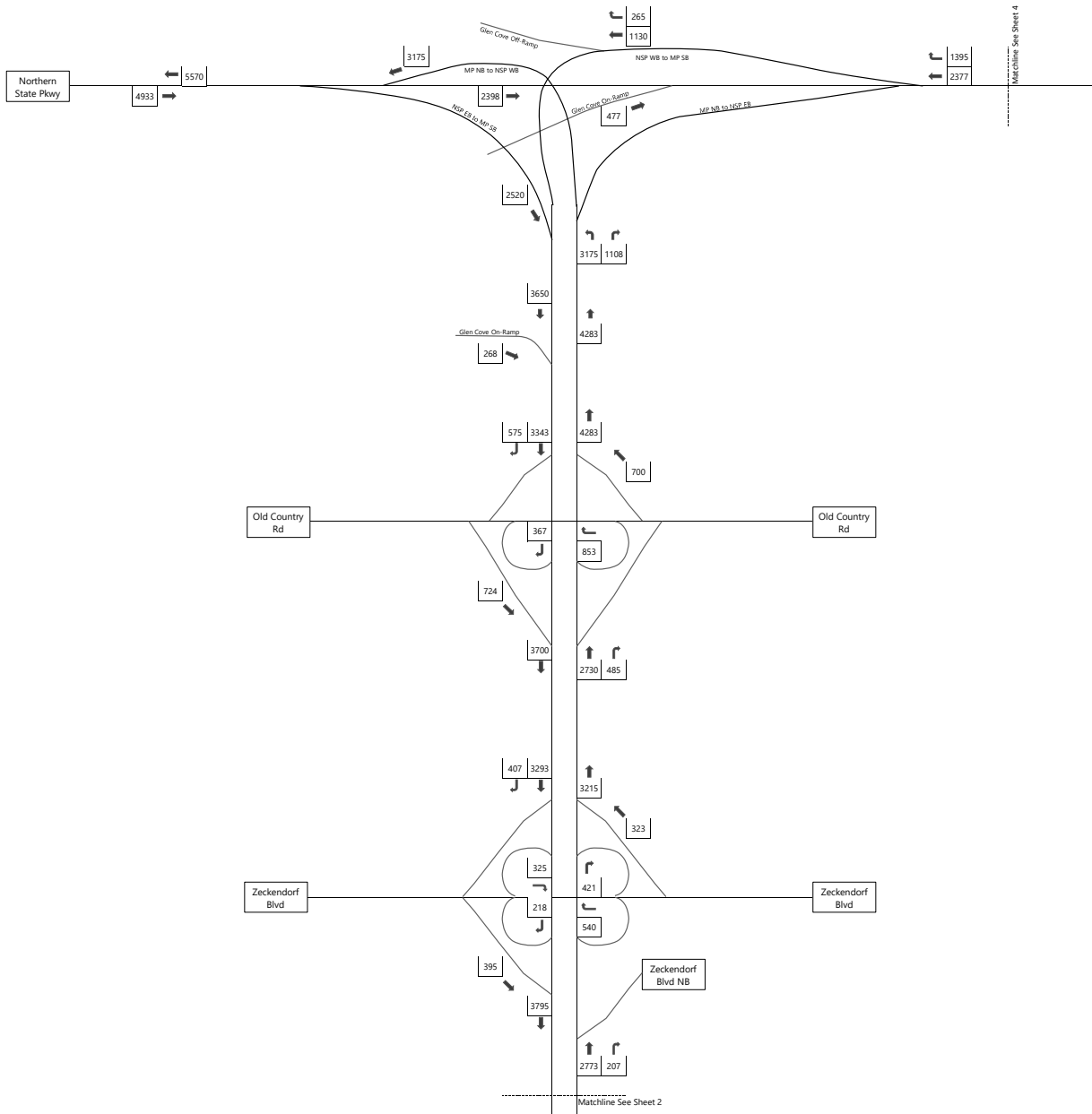

Figure V-C-5, Sheet 1
 2030 No-Build Parkway Traffic Volumes
 Saturday Evening Peak Hour
 26841.01 - Sands New York Integrated Resort
 Meadowbrook State Parkway



Not to Scale



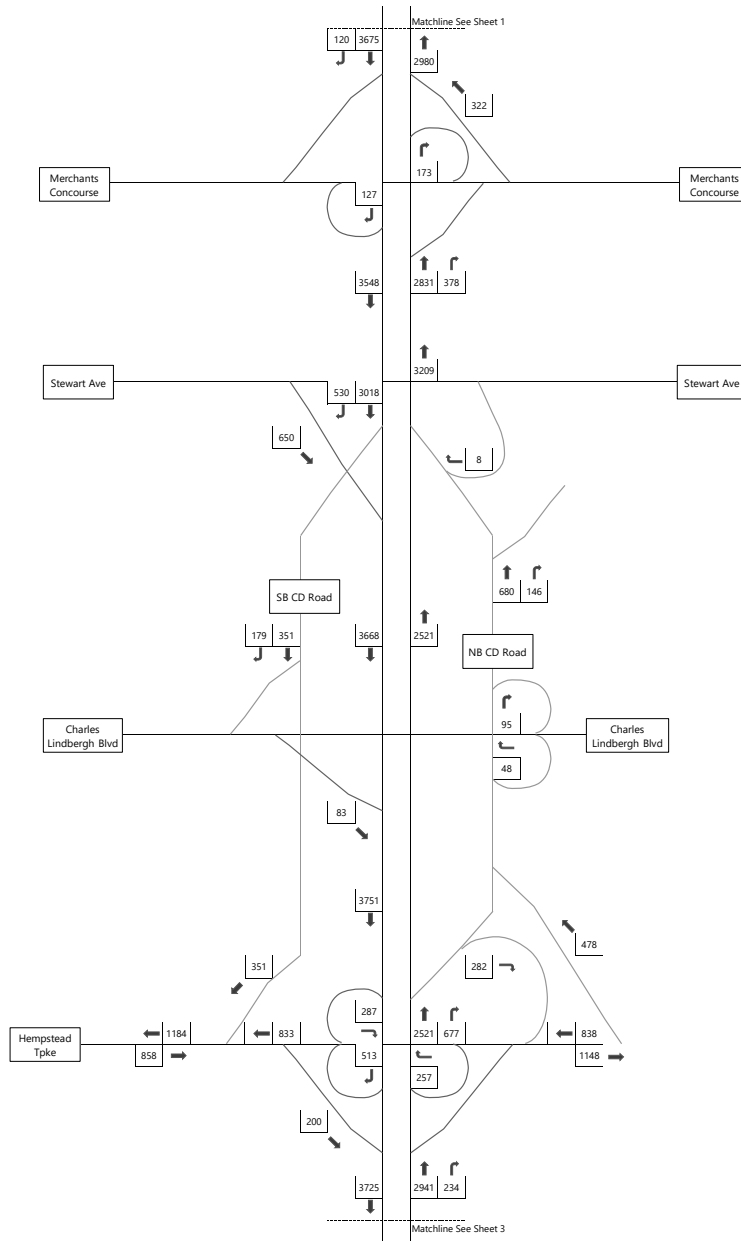

Figure V-C-5, Sheet 2
 2030 No-Build Parkway Traffic Volumes
 Saturday Evening Peak Hour
 26841.01 - Sands New York Integrated Resort
 Meadowbrook State Parkway



Not to Scale



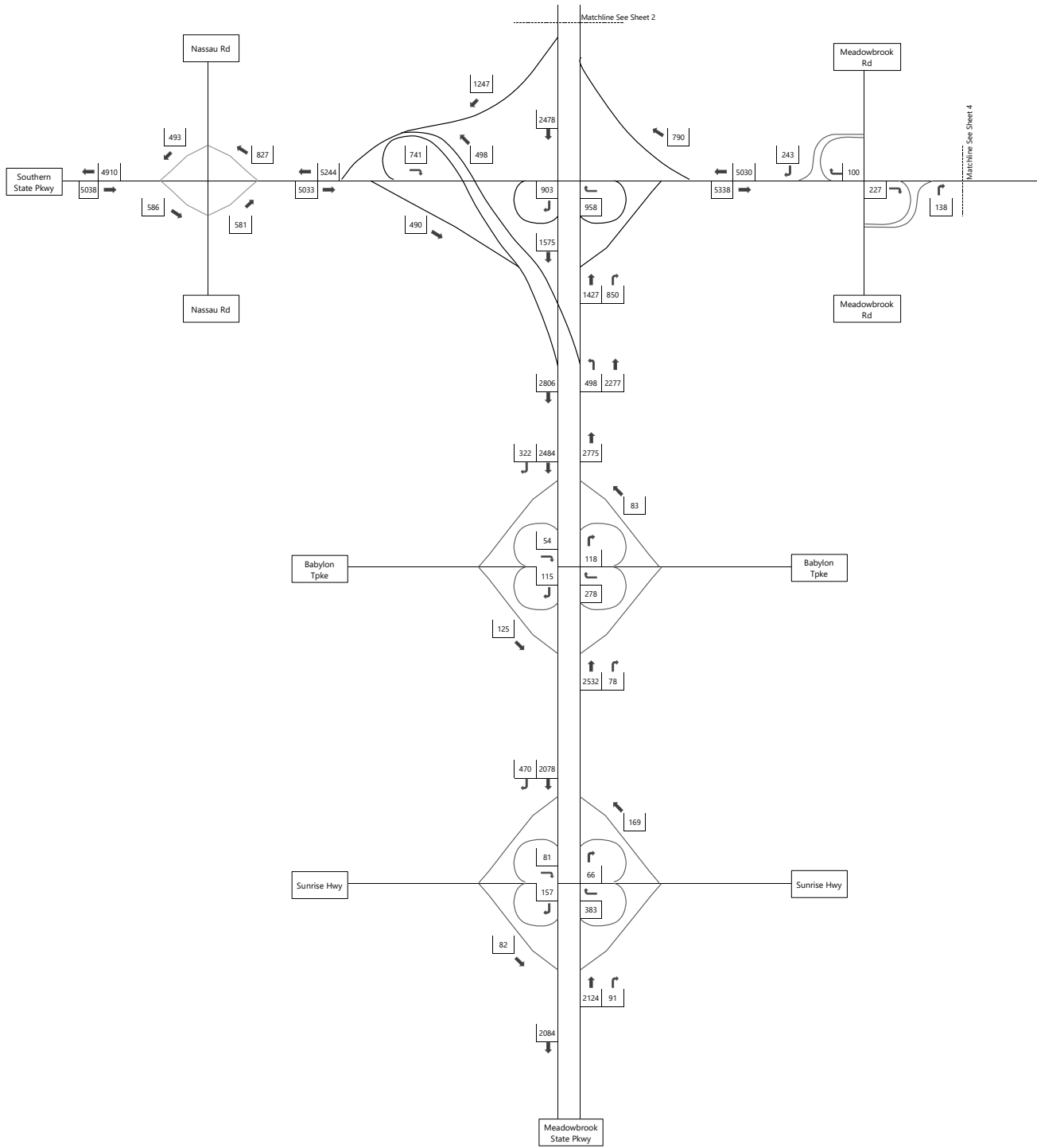

Figure V-C-5, Sheet 3
 2030 No-Build Parkway Traffic Volumes
 Saturday Evening Peak Hour
 26841.01 - Sands New York Integrated Resort
 Meadowbrook State Parkway



Not to Scale



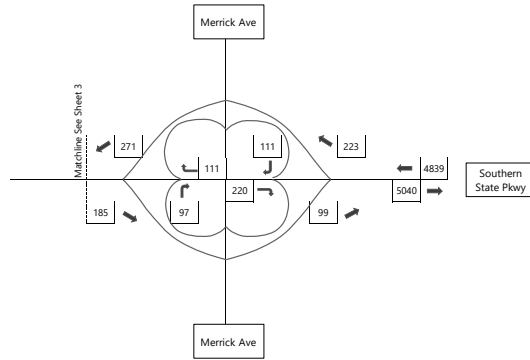
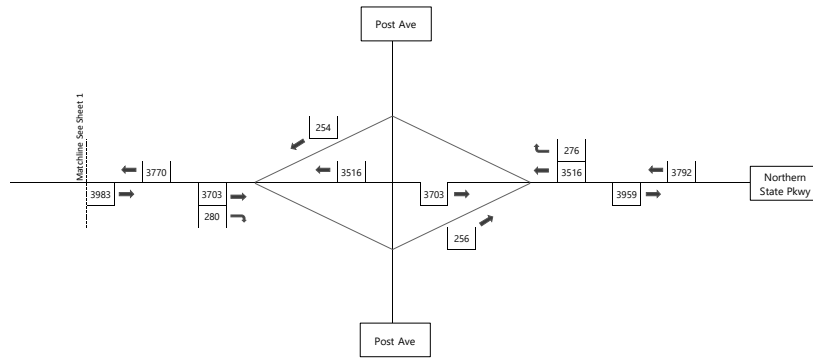

Figure V-C-5, Sheet 4
 2030 No-Build Parkway Traffic Volumes
 Saturday Evening Peak Hour
 26841.01 - Sands New York Integrated Resort
 Meadowbrook State Parkway



Not to Scale



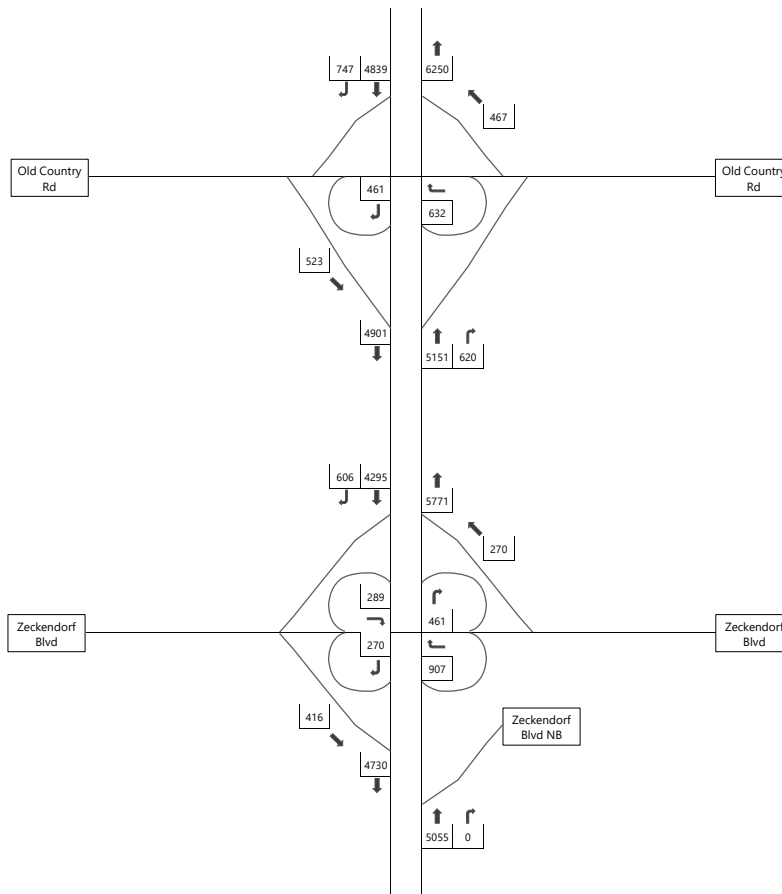

Figure V-C-6, Sheet 1
 2030 No-Build Parkway Traffic Volumes
 Weekday PM Peak Hour - Holiday
 26841.01 - Sands New York Integrated Resort
 Meadowbrook State Parkway



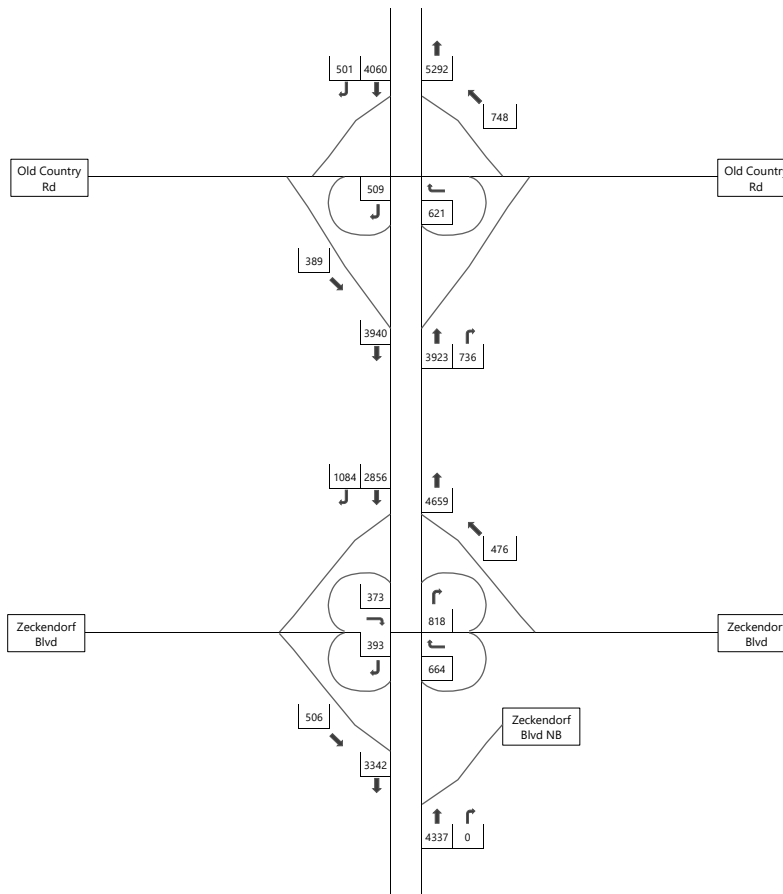

Figure V-C-7, Sheet 1
 2030 No-Build Traffic Volumes
 Saturday Midday Peak Hour - Holiday
 26841.01 - Sands New York Integrated Resort
 Meadowbrook State Parkway





2030 Full Build

V-D 2030 Trip Assignments

**26841.01: Sands Integrated Resort
Traffic Impact Study Attachments
Attachment F – Parkway Peak Hour Traffic Volume Figures**



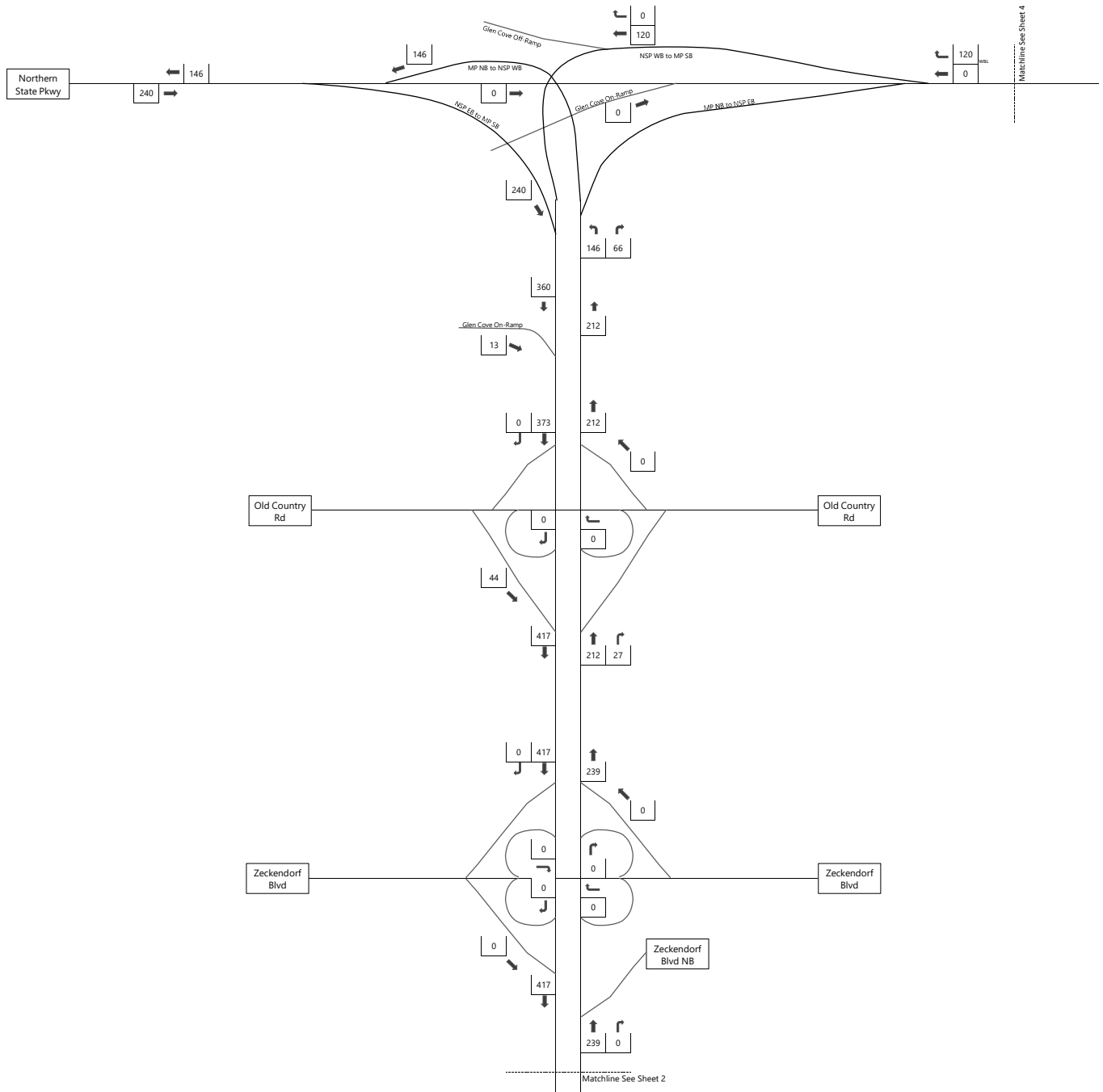

Figure V-D-1, Sheet 1
 2030 Combined Trip Assignment
 Weekday AM Peak Hour
 26841.01 - Sands New York Integrated Resort
 Meadowbrook State Parkway



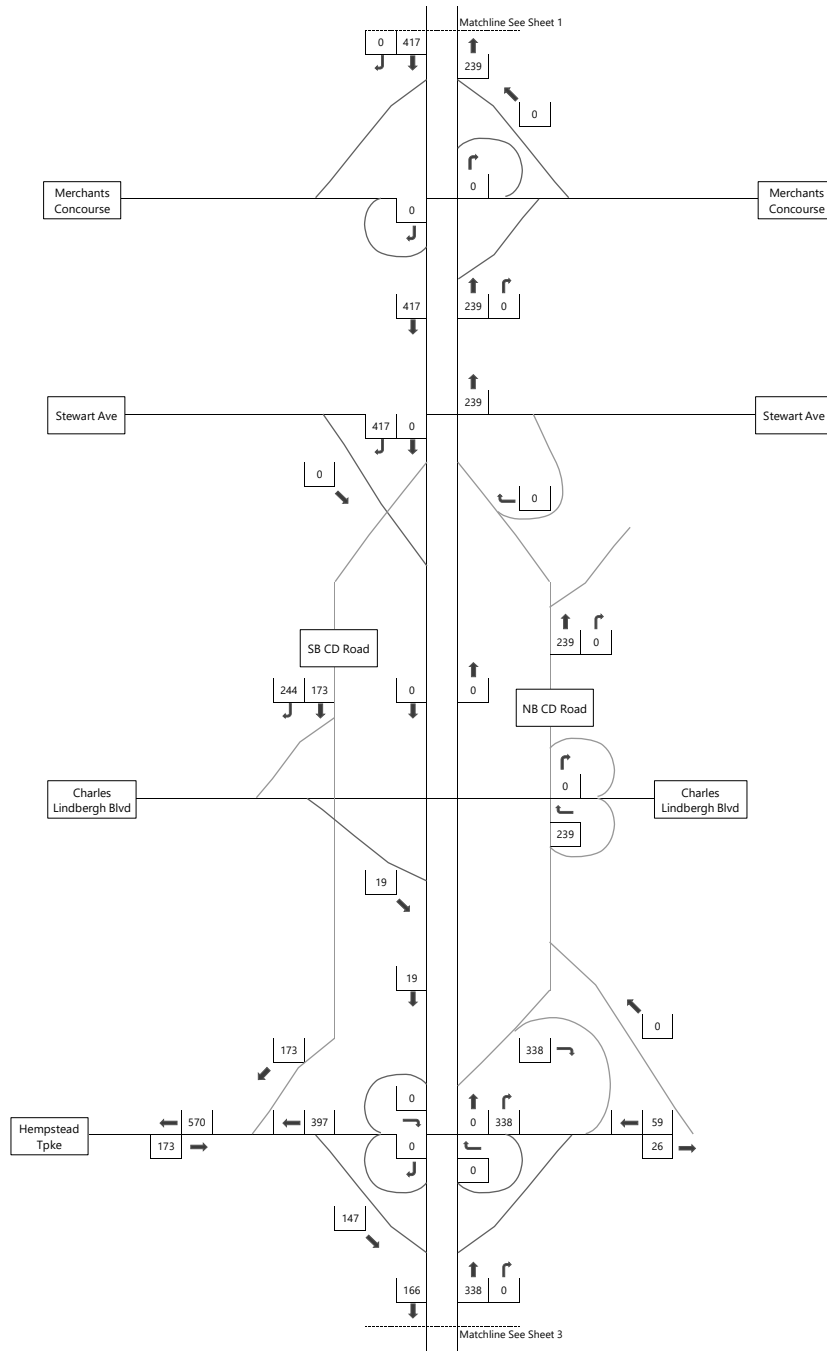

Figure V-D-1, Sheet 2
 2030 Combined Trip Assignment
 Weekday AM Peak Hour
 26841.01 - Sands New York Integrated Resort
 Meadowbrook State Parkway



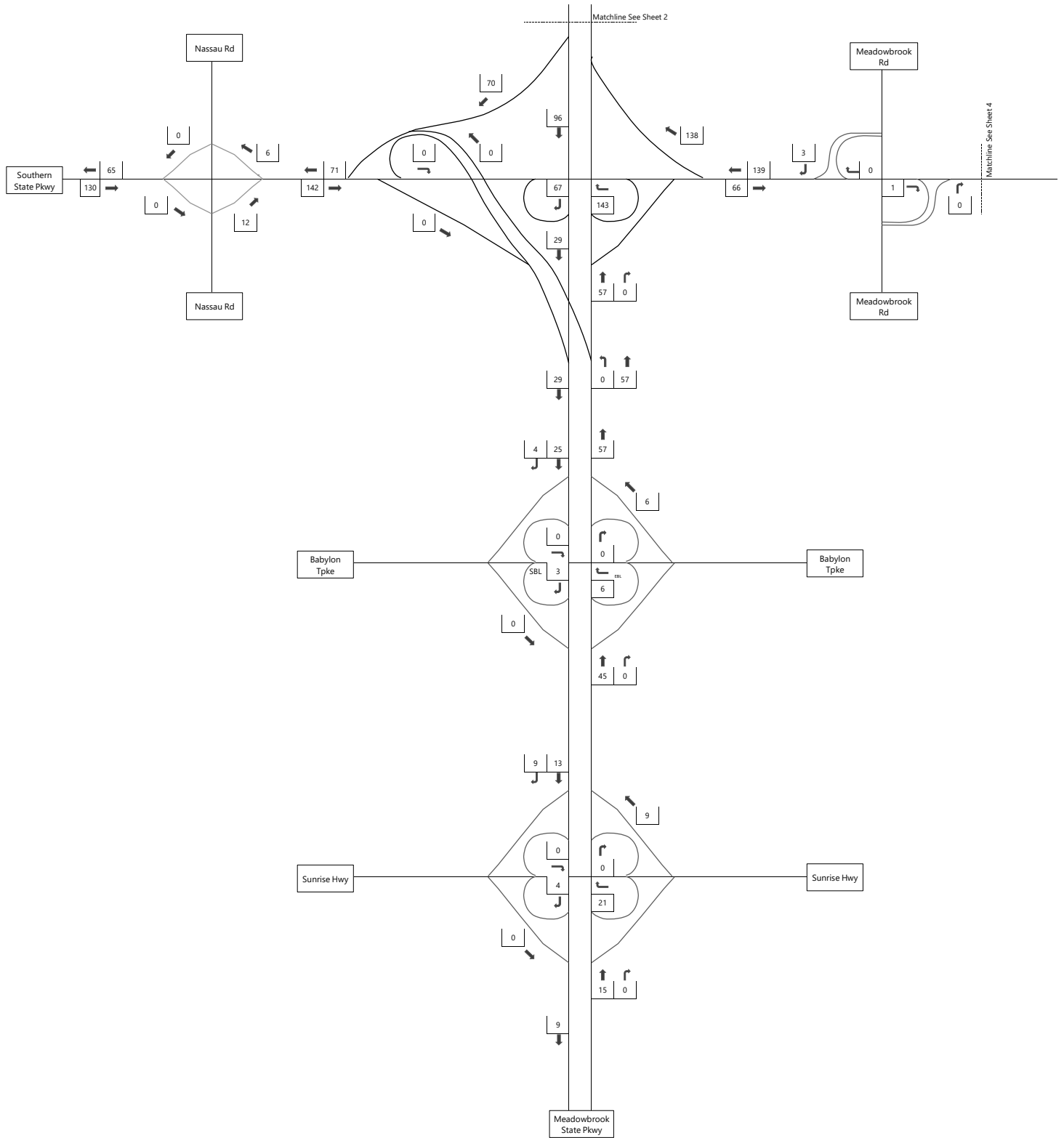

Figure V-D-1, Sheet 3
 2030 Combined Trip Assignment
 Weekday AM Peak Hour
 26841.01 - Sands New York Integrated Resort
 Meadowbrook State Parkway



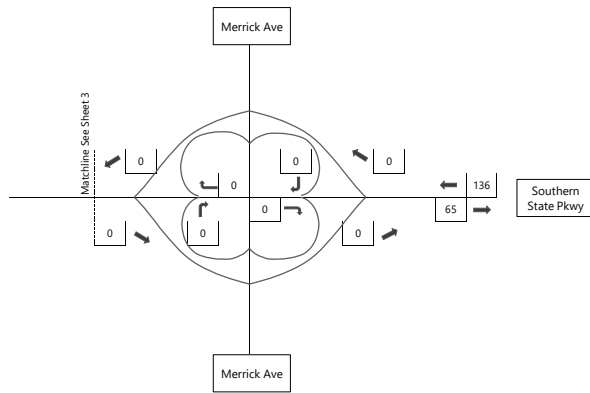
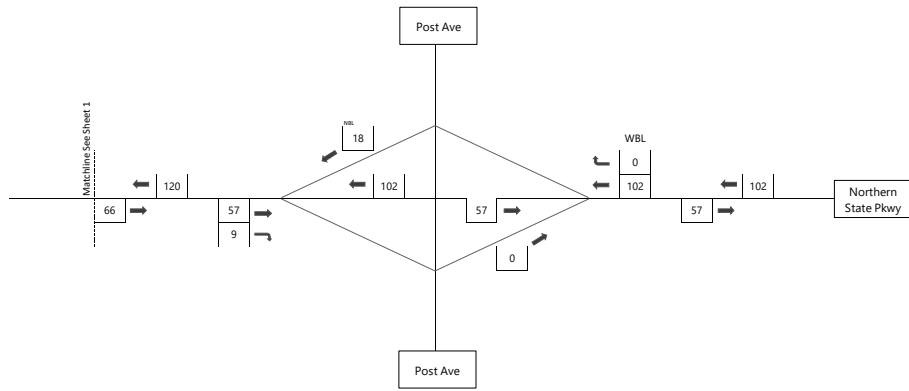

Figure V-D-1, Sheet 4
 2030 Combined Trip Assignment
 Weekday AM Peak Hour
 26841.01 - Sands New York Integrated Resort
 Meadowbrook State Parkway



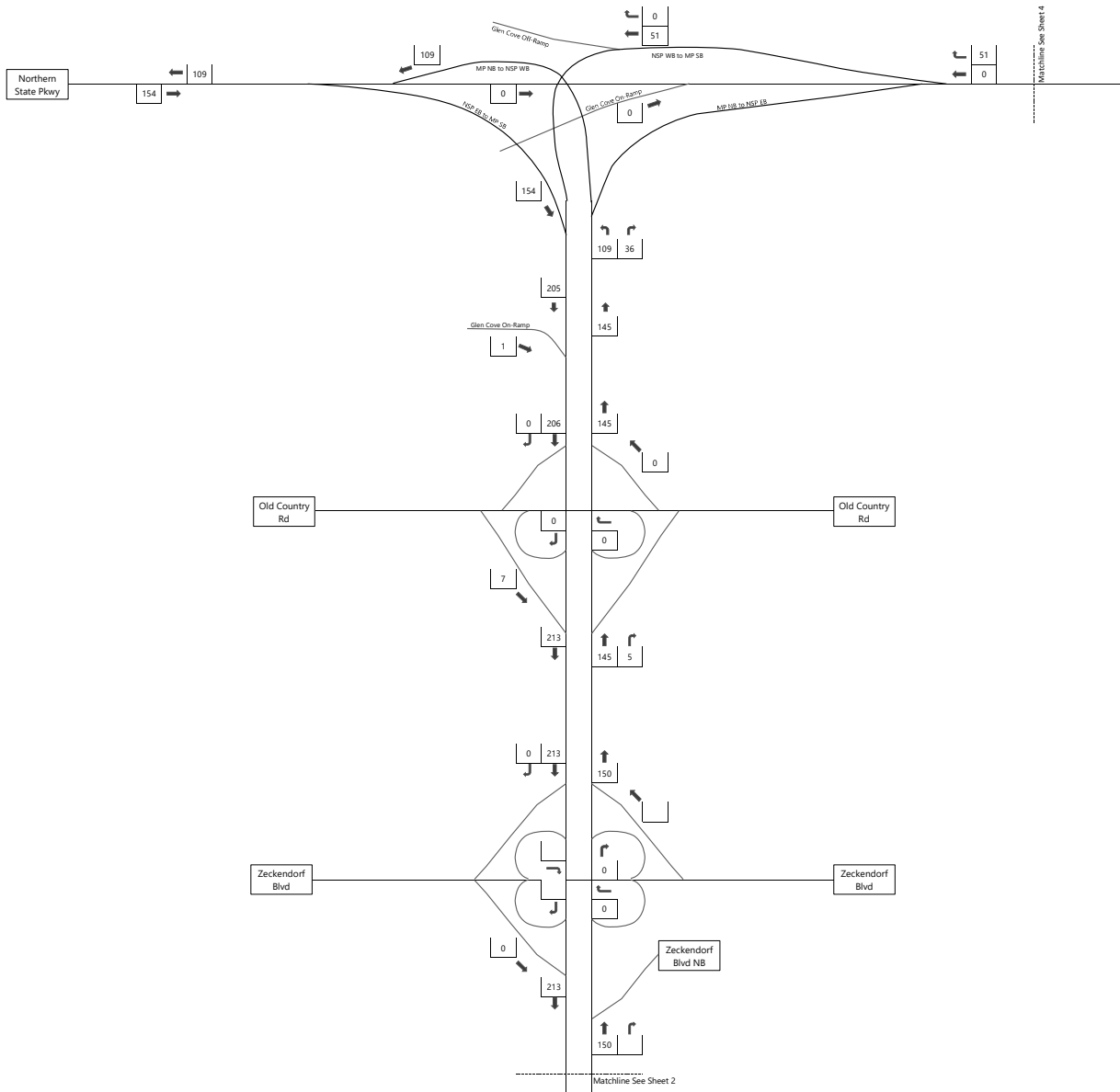

Figure V-D-1-1, Sheet 1
 2030 Trip Assignment - Casino/Hotel
 Weekday AM Peak Hour
 26841.01 - Sands New York Integrated Resort
 Meadowbrook State Parkway



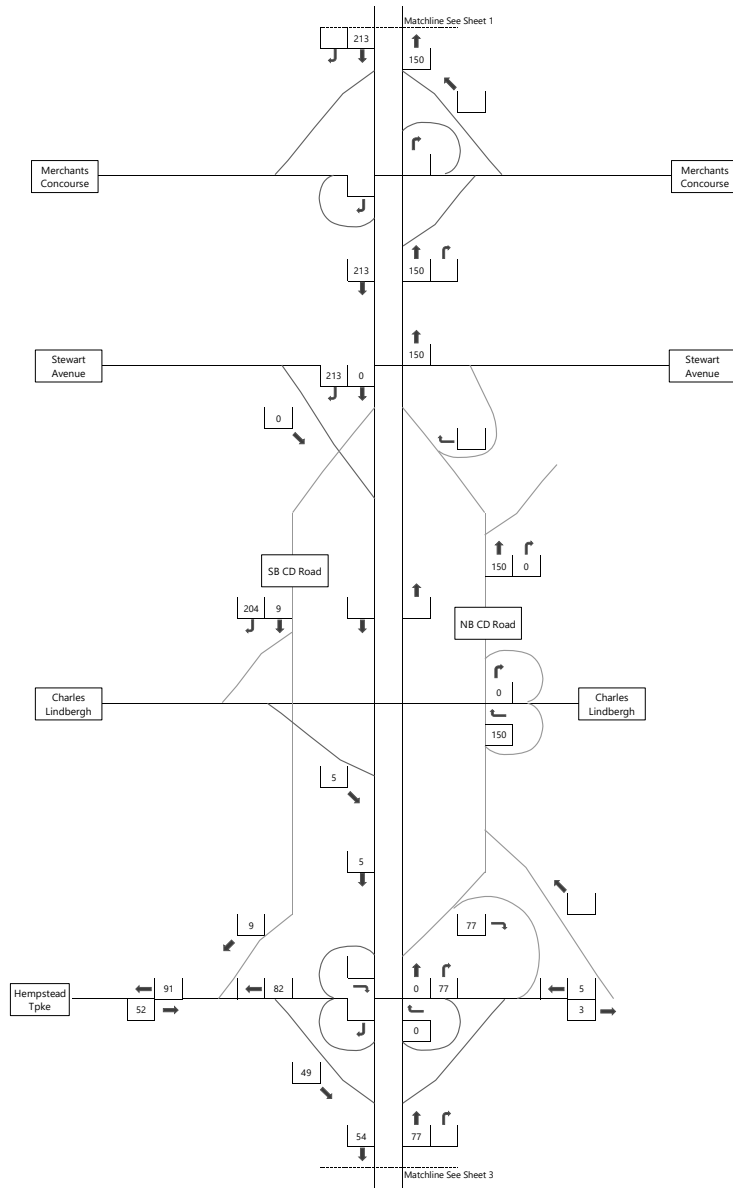

Figure V-D-1-1, Sheet 2
 2030 Trip Assignment - Casino/Hotel
 Weekday AM Peak Hour
 26841.01 - Sands New York Integrated Resort
 Meadowbrook State Parkway



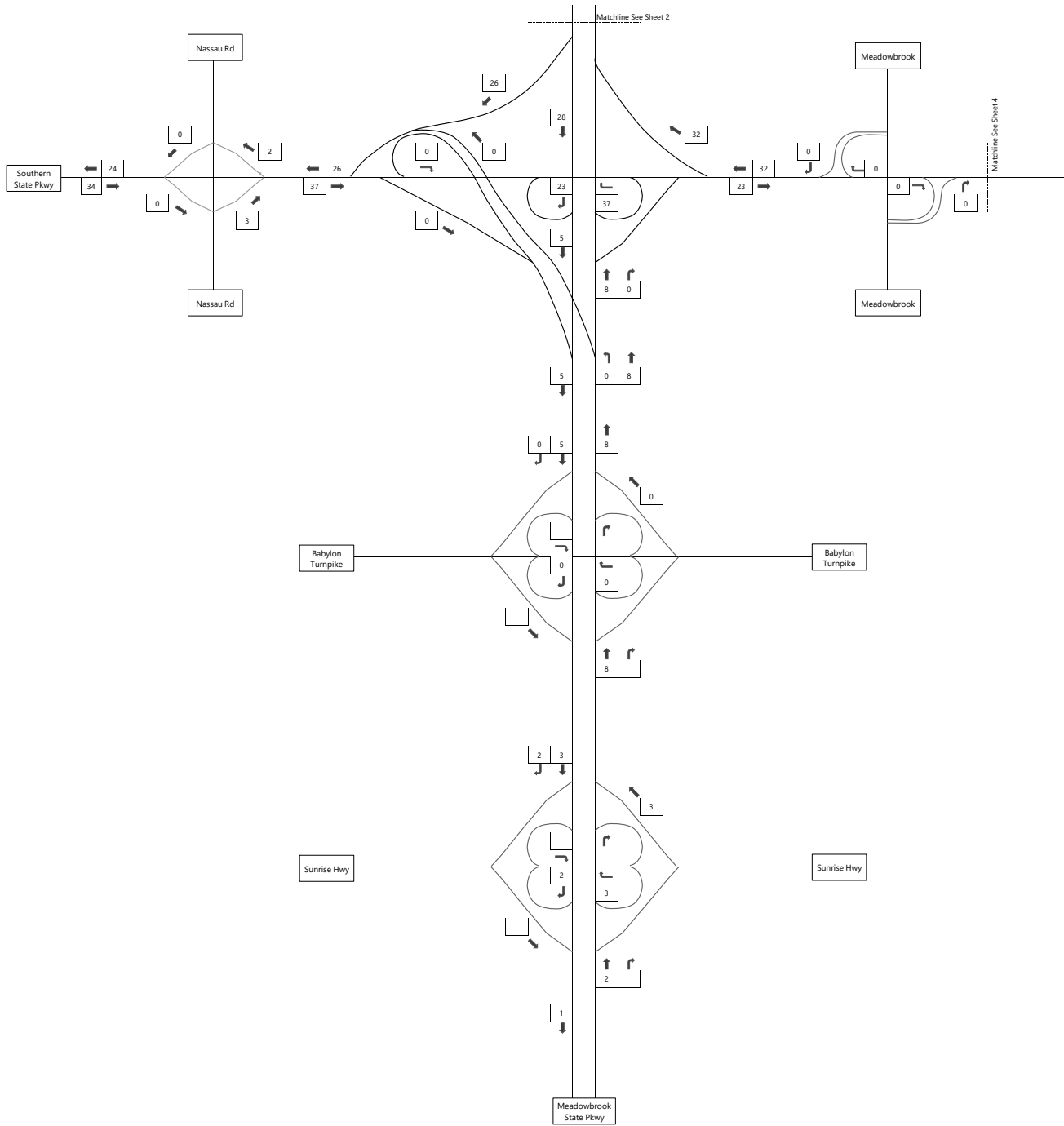

Figure V-D-1-1, Sheet 3
 2030 Trip Assignment - Casino/Hotel
 Weekday AM Peak Hour
 26841.01 - Sands New York Integrated Resort
 Meadowbrook State Parkway



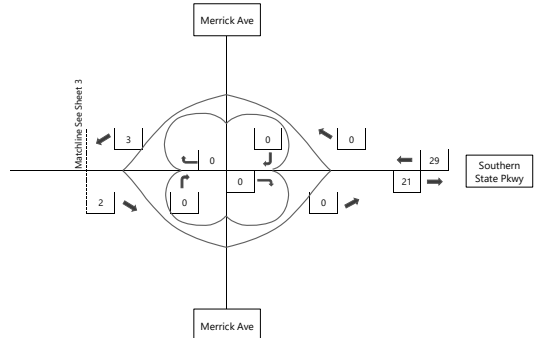
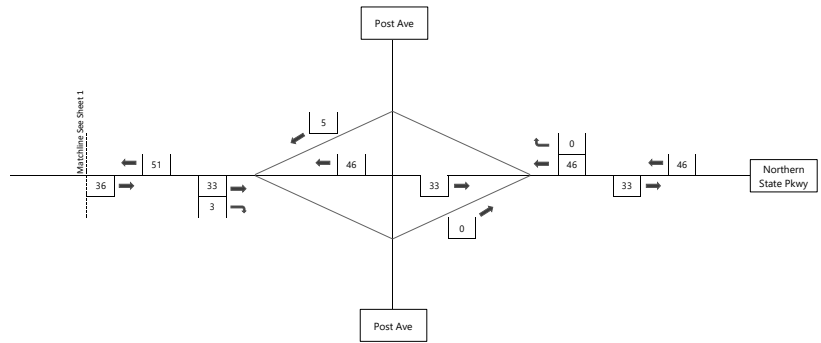

Figure V-D-1-1, Sheet 4
 2030 Trip Assignment - Casino/Hotel
 Weekday AM Peak Hour
 26841.01 - Sands New York Integrated Resort
 Meadowbrook State Parkway



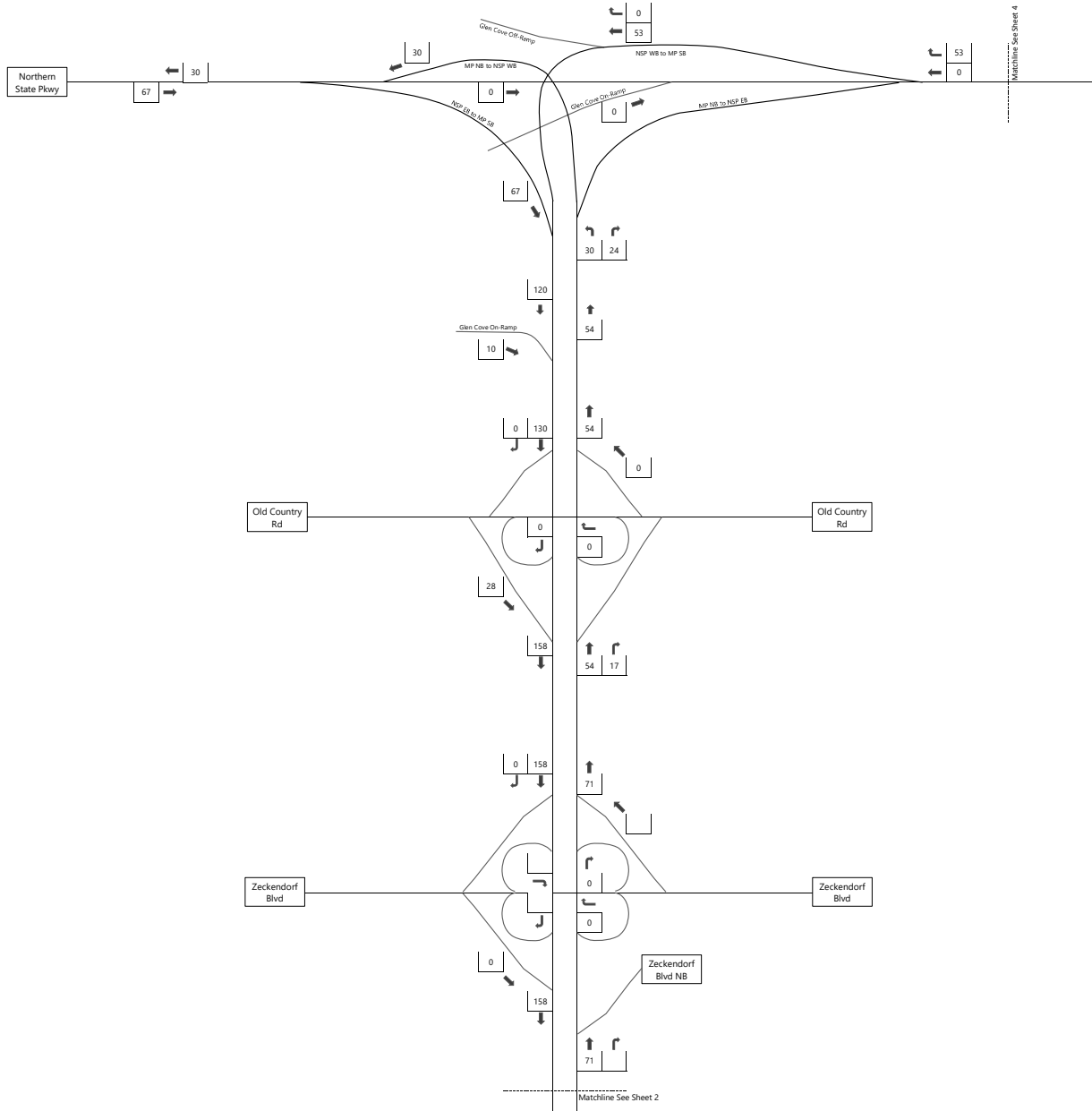

Figure V-D-1-2, Sheet 1
 2030 Trip Assignment - Employee
 Weekday AM Peak Hour
 26841.01 - Sands New York Integrated Resort
 Meadowbrook State Parkway



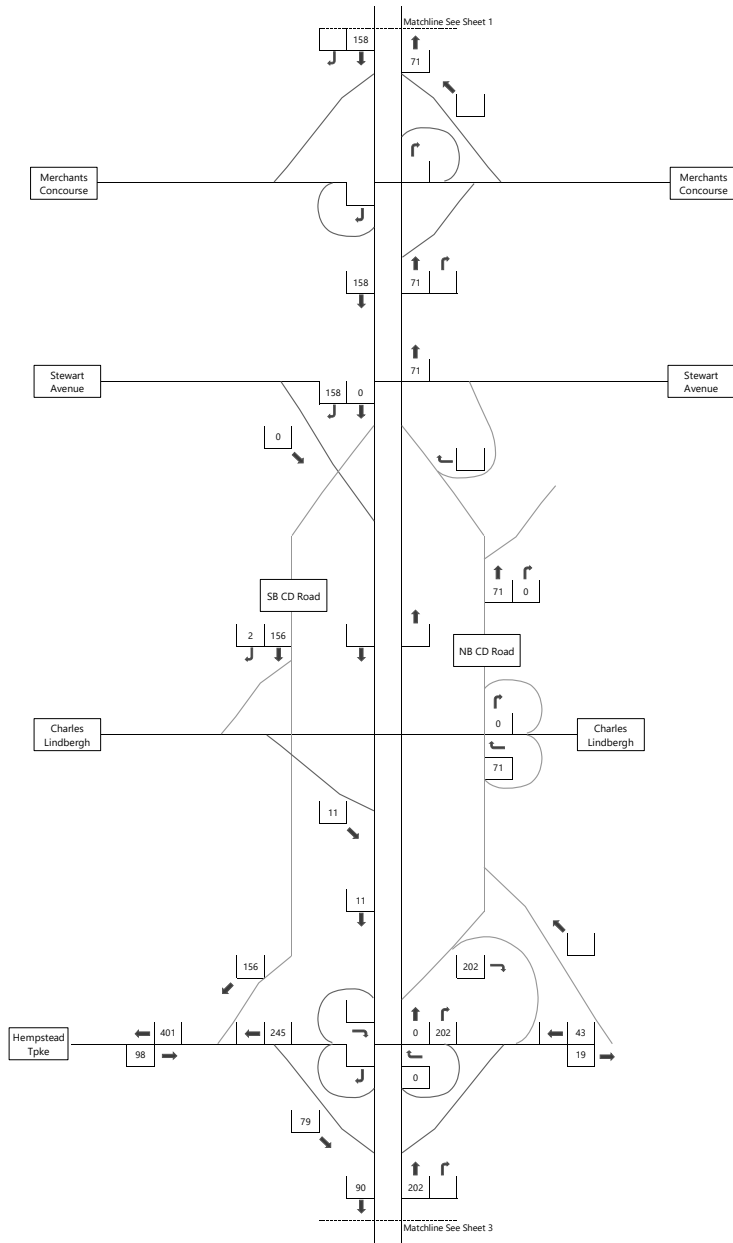

Figure V-D-1-2, Sheet 2
 2030 Trip Assignment - Employee
 Weekday AM Peak Hour
 26841.01 - Sands New York Integrated Resort
 Meadowbrook State Parkway



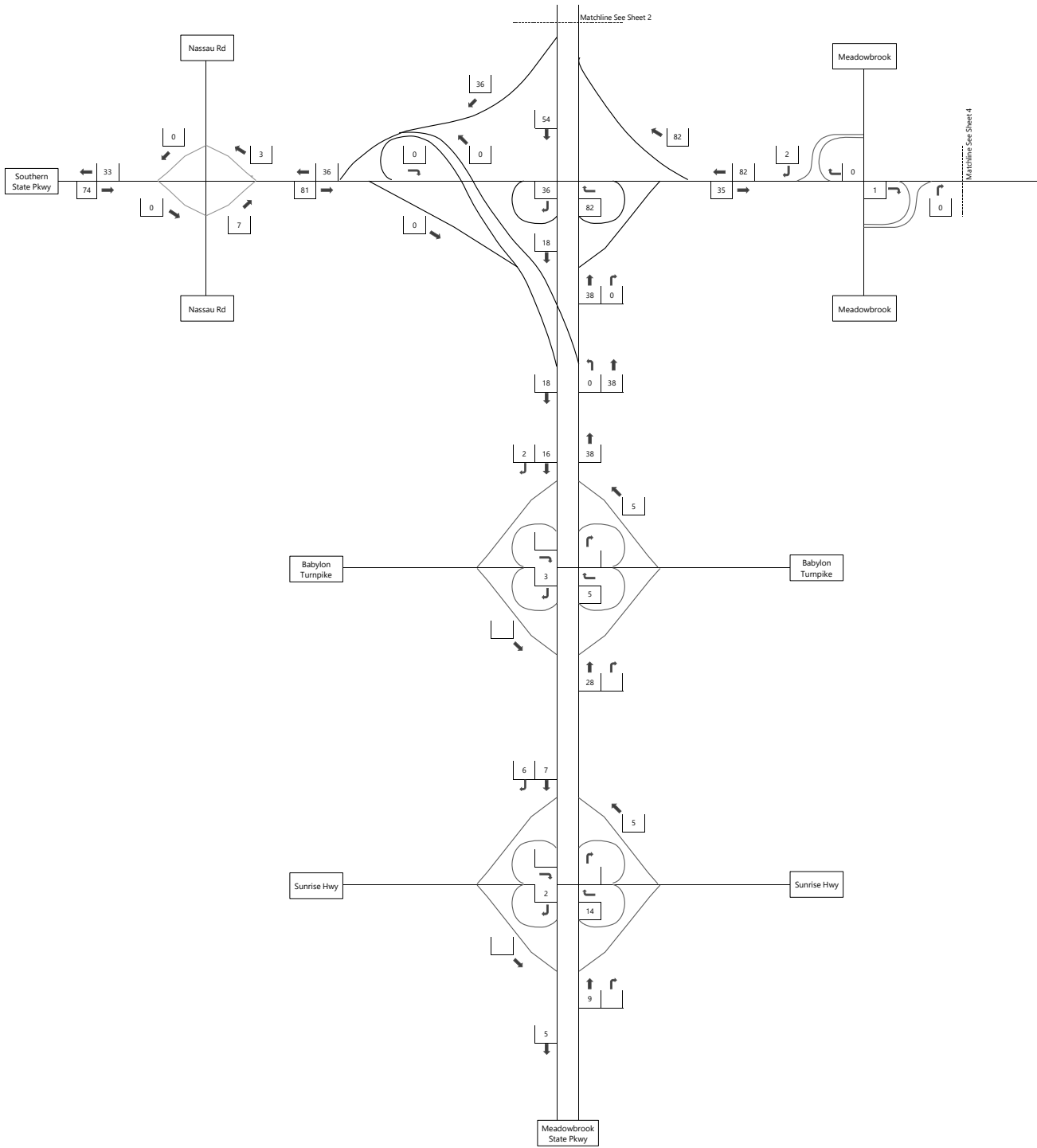

Figure V-D-1-2, Sheet 3
 2030 Trip Assignment - Employee
 Weekday AM Peak Hour
 26841.01 - Sands New York Integrated Resort
 Meadowbrook State Parkway



Not to Scale



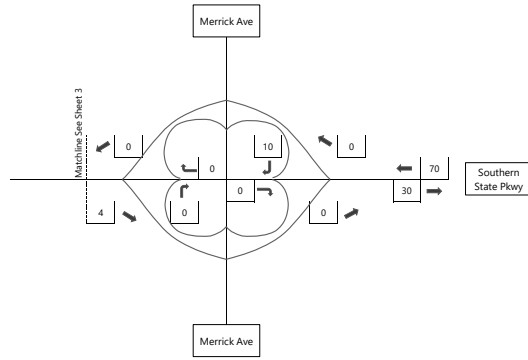
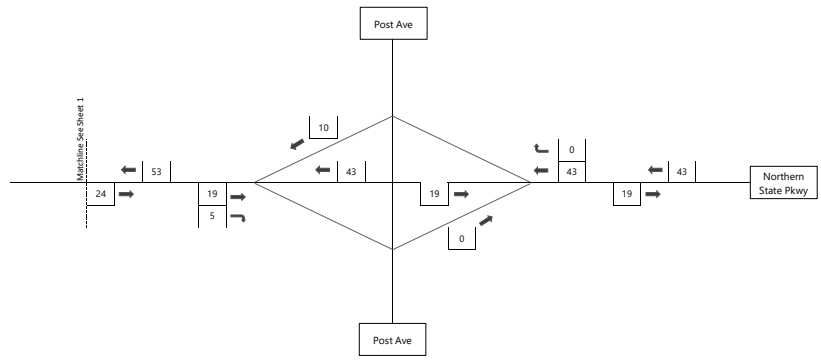

Figure V-D-1-2, Sheet 4
 2030 Trip Assignment - Employee
 Weekday AM Peak Hour
 26841.01 - Sands New York Integrated Resort
 Meadowbrook State Parkway



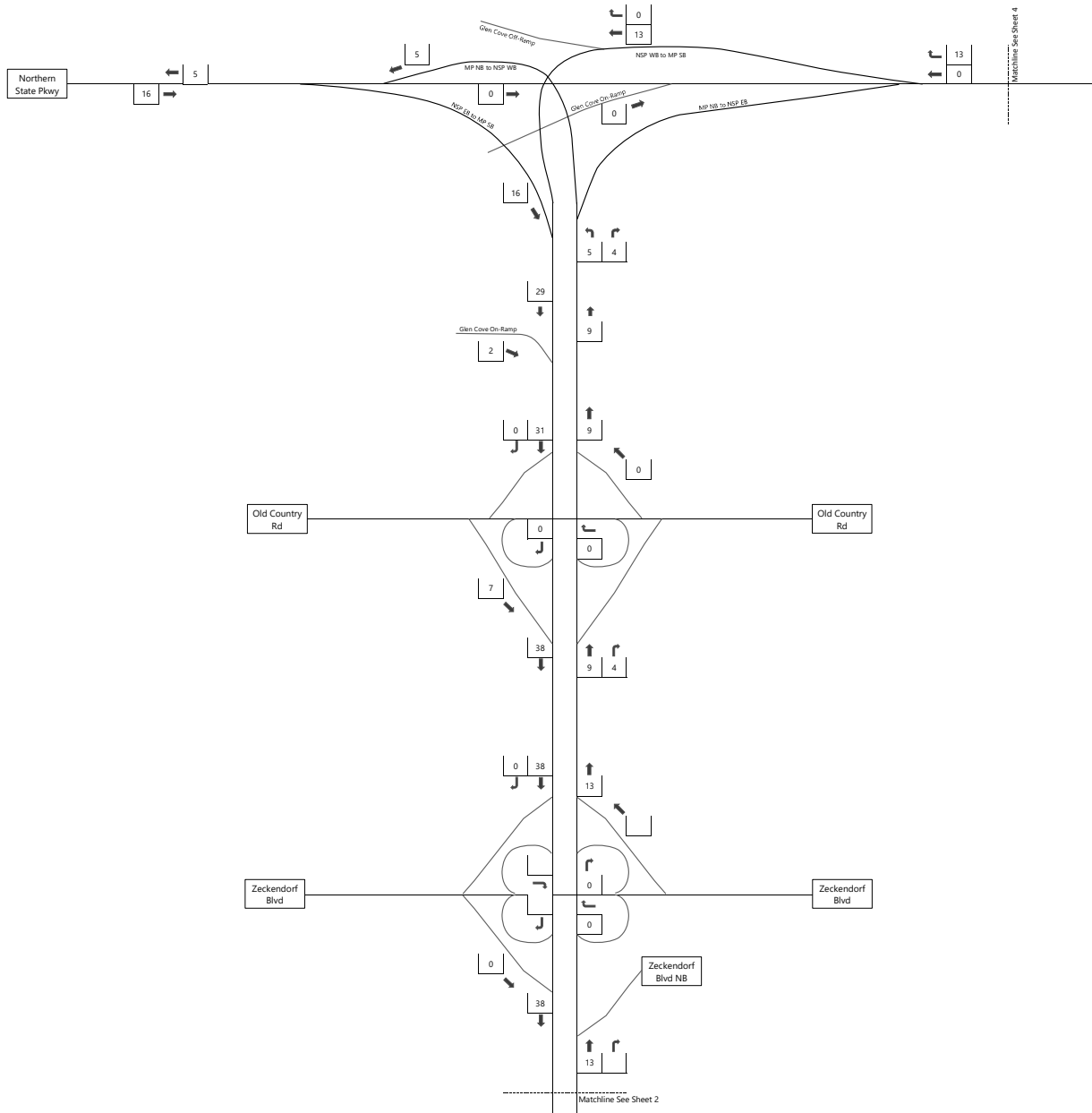

Figure V-D-1-3, Sheet 1
 2030 Trip Assignment - Restaurant/Retail/Public Attraction,
 Theater, Meetings and Conference
 Weekday AM Peak Hour
 26841.01 - Sands New York Integrated Resort
 Meadowbrook State Parkway



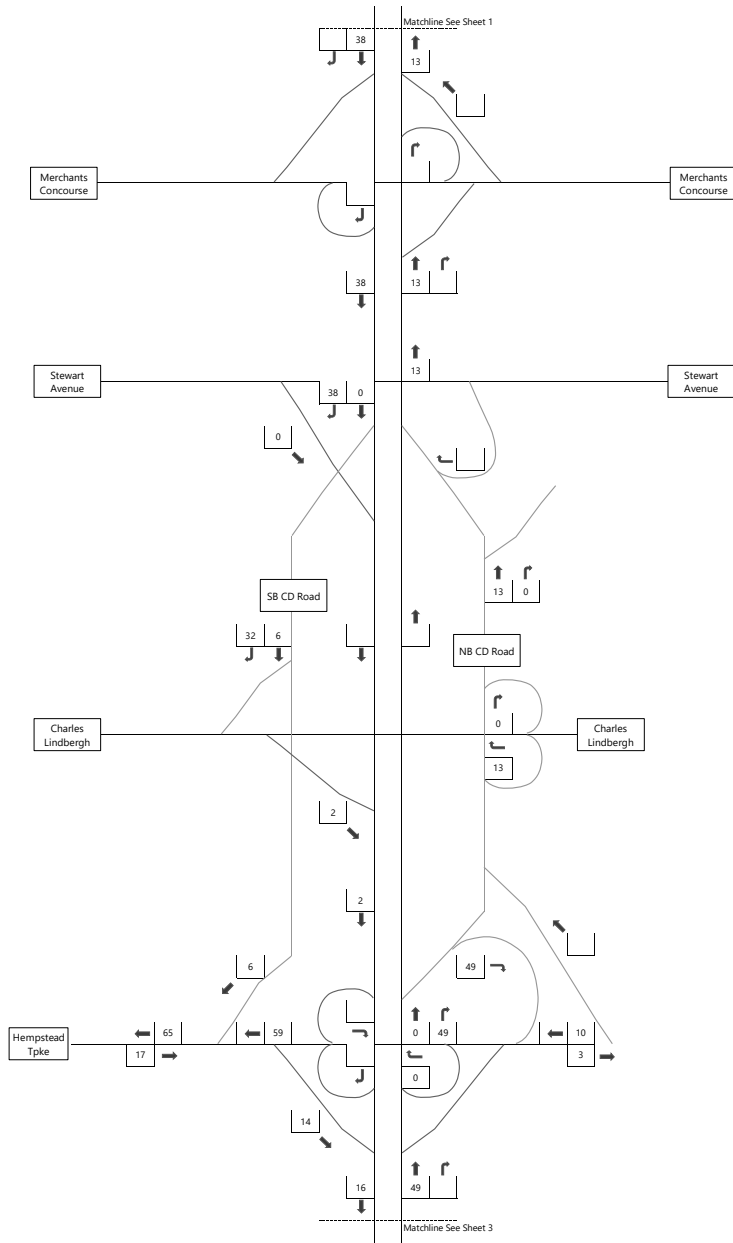

Figure V-D-1-3, Sheet 2
 2030 Trip Assignment - Restaurant/Retail/Public Attraction,
 Theater, Meetings and Conference
 Weekday AM Peak Hour
 26841.01 - Sands New York Integrated Resort
 Meadowbrook State Parkway



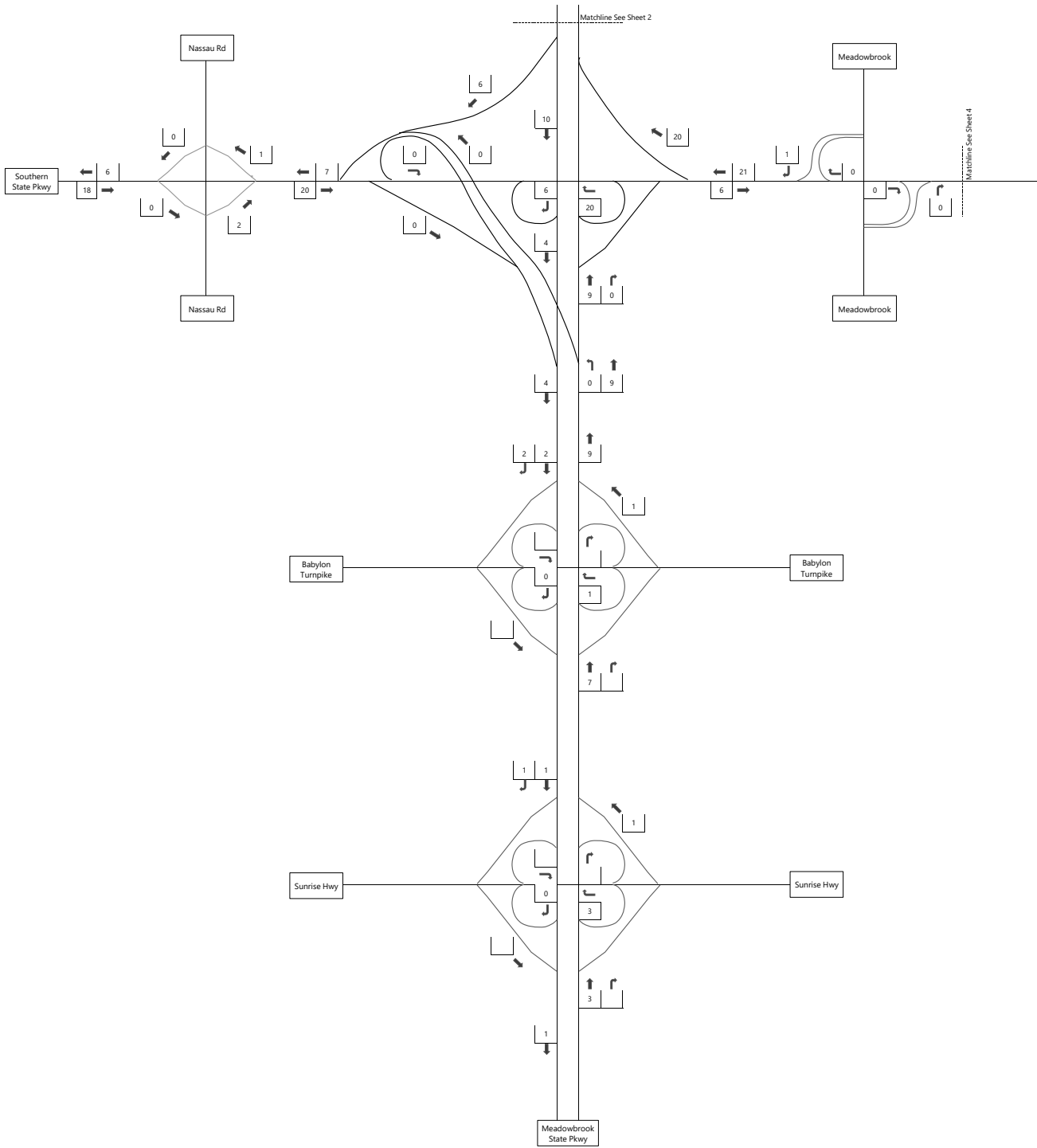

Figure V-D-1-3, Sheet 3
 2030 Trip Assignment - Restaurant/Retail/Public Attraction,
 Theater, Meetings and Conference
 Weekday AM Peak Hour
 26841.01 - Sands New York Integrated Resort
 Meadowbrook State Parkway



Not to Scale



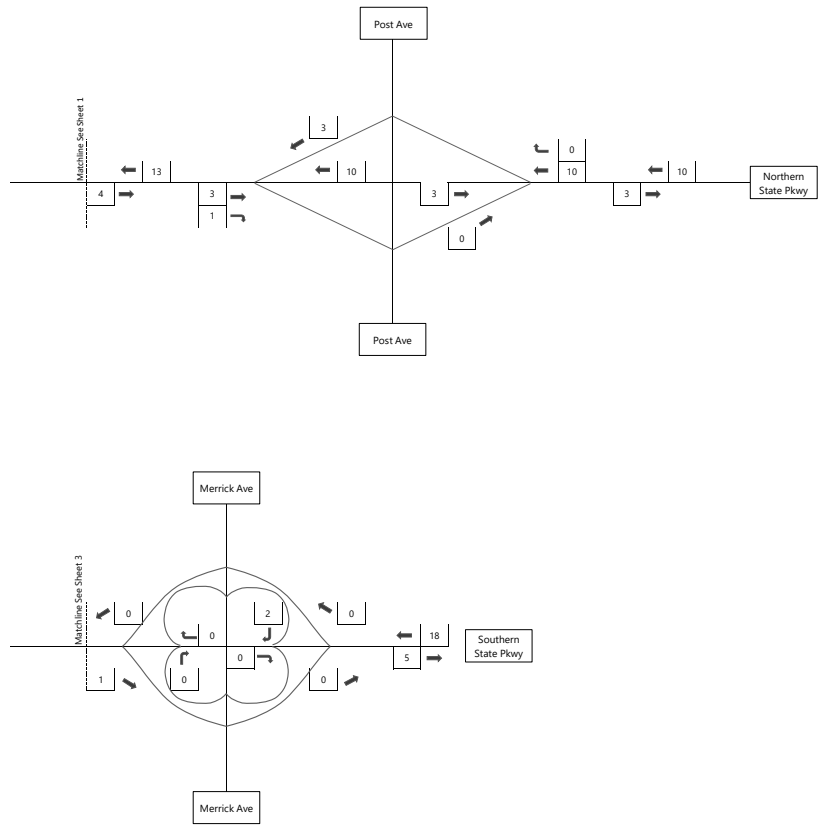

Figure V-D-1-3, Sheet 4
 2030 Trip Assignment - Restaurant/Retail/Public Attraction,
 Theater, Meetings and Conference
 Weekday AM Peak Hour
 26841.01 - Sands New York Integrated Resort
 Meadowbrook State Parkway



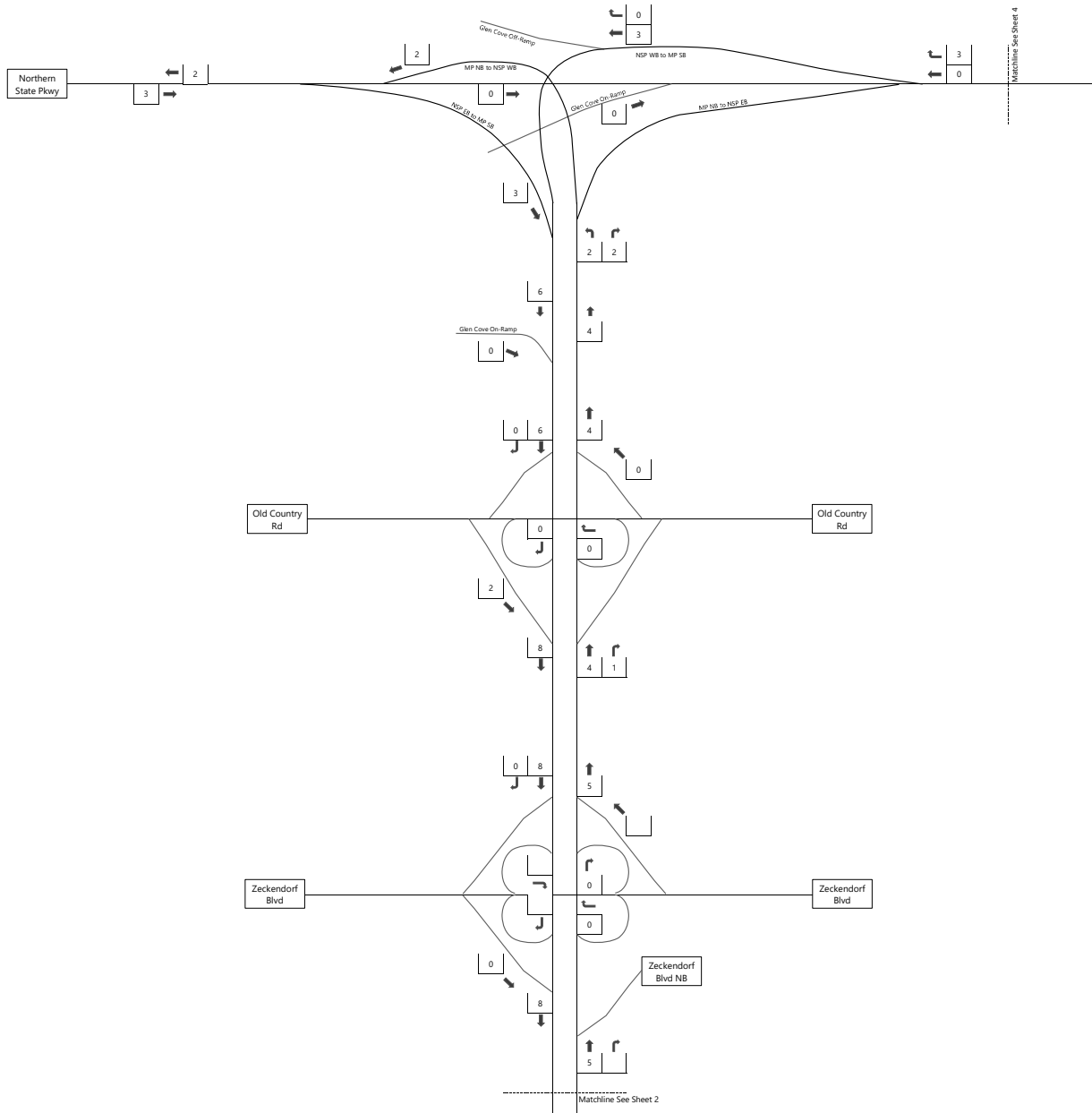

Figure V-D-1-4, Sheet 1
 2030 Trip Assignment - Ridehailing
 Weekday AM Peak Hour
 26841.01 - Sands New York Integrated Resort
 Meadowbrook State Parkway



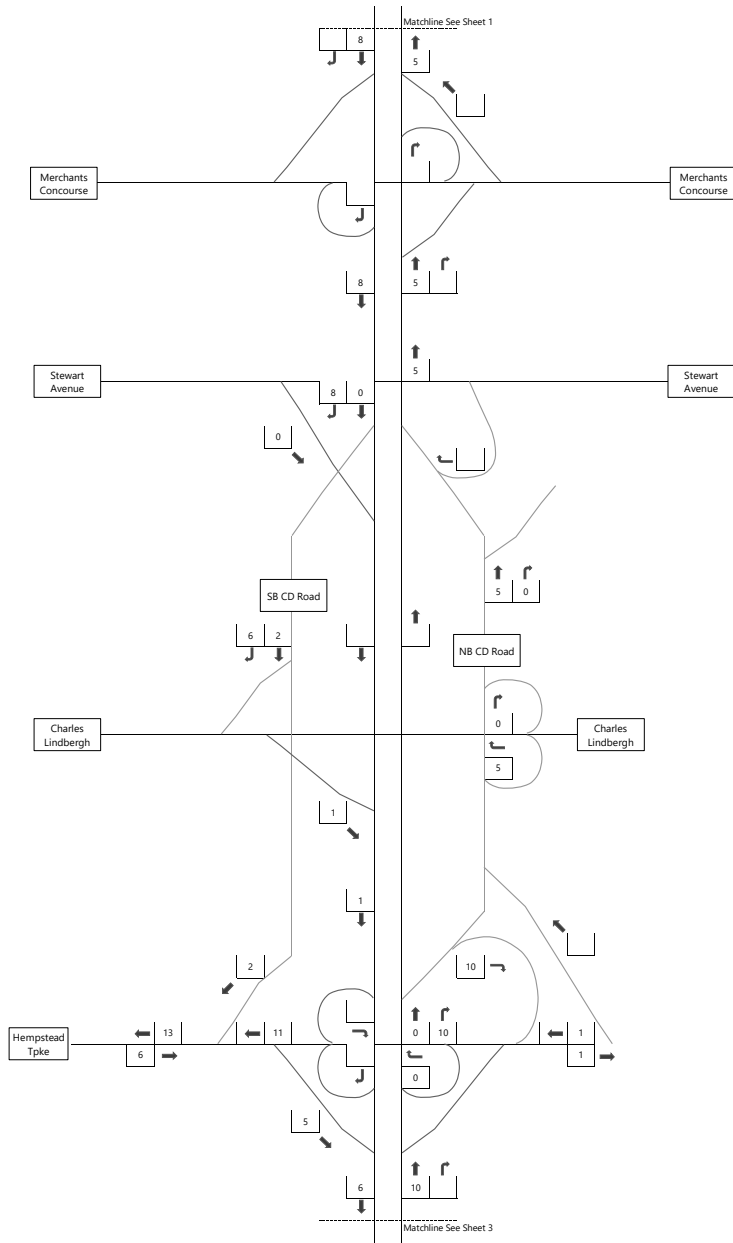

Figure V-D-1-4, Sheet 2
 2030 Trip Assignment - Ridehailing
 Weekday AM Peak Hour
 26841.01 - Sands New York Integrated Resort
 Meadowbrook State Parkway



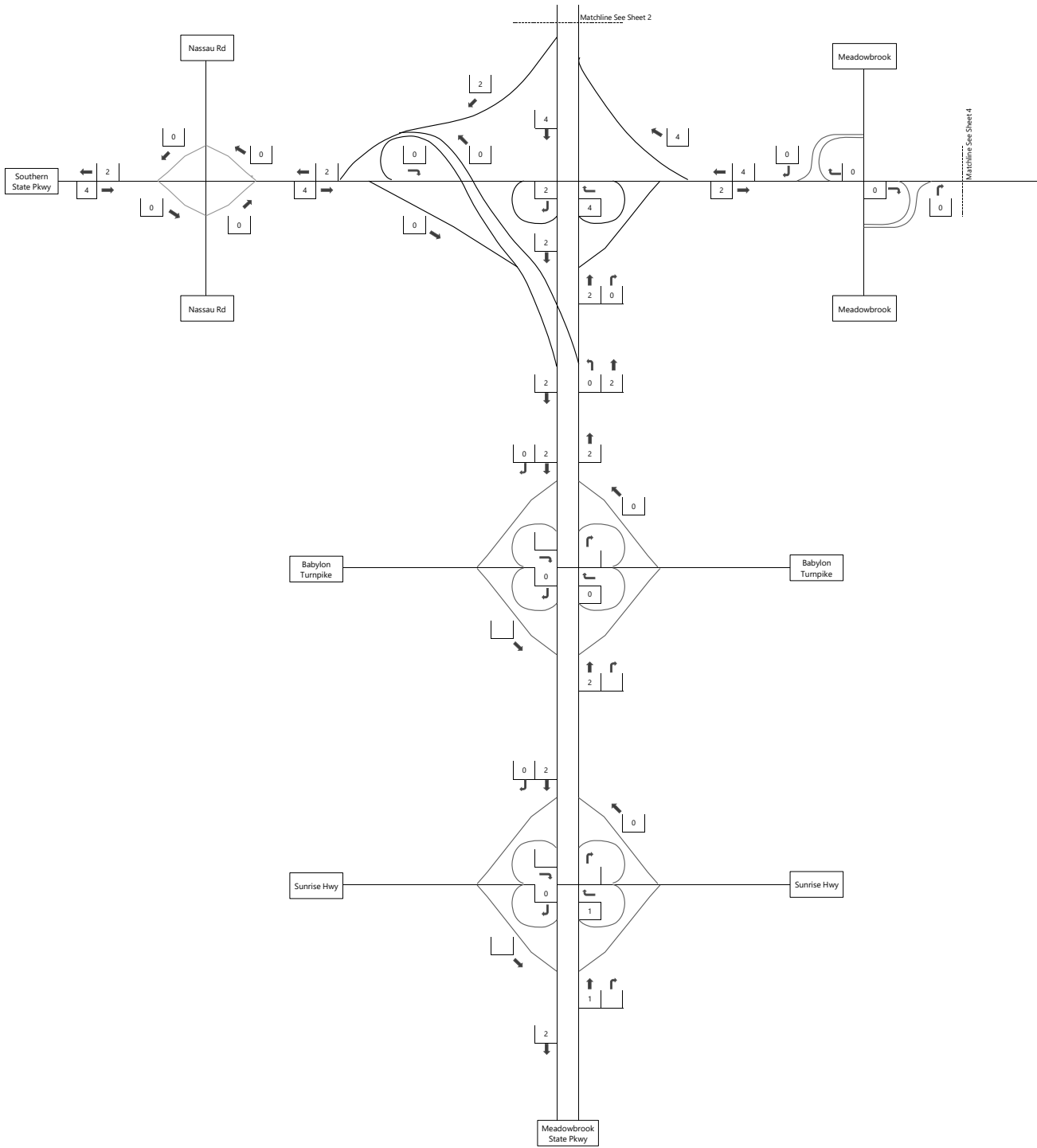

Figure V-D-1-4, Sheet 3
 2030 Trip Assignment - Ridehailing
 Weekday AM Peak Hour
 26841.01 - Sands New York Integrated Resort
 Meadowbrook State Parkway



Not to Scale



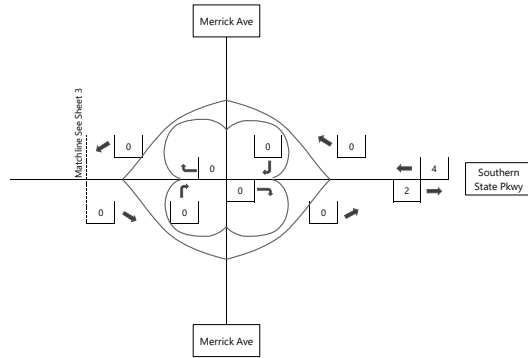
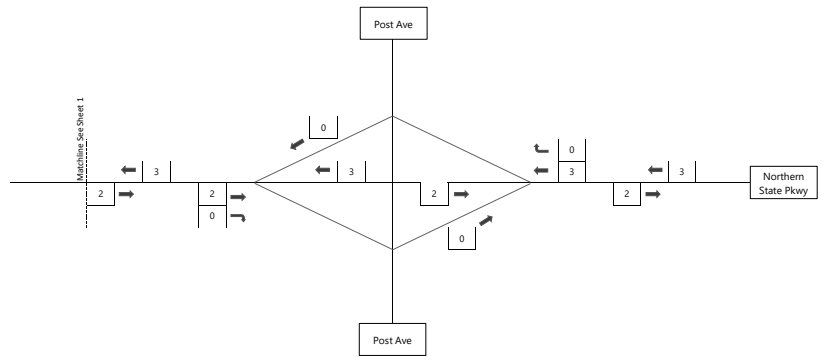

Figure V-D-1-4, Sheet 4
 2030 Trip Assignment - Ridehailing
 Weekday AM Peak Hour
 26841.01 - Sands New York Integrated Resort
 Meadowbrook State Parkway



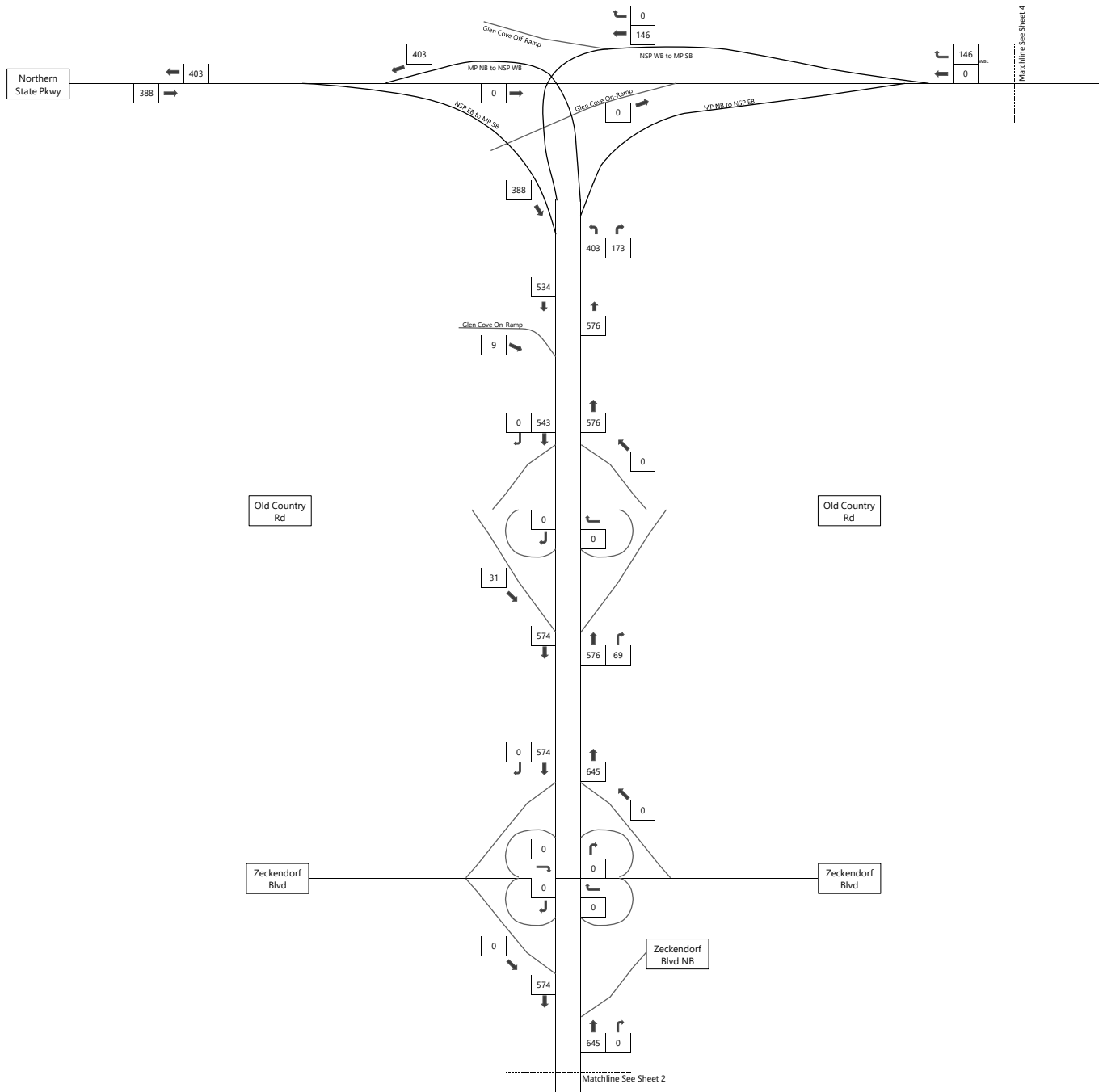

Figure V-D-2, Sheet 1
 2030 Combined Trip Assignment
 Weekday PM Peak Hour
 26841.01 - Sands New York Integrated Resort
 Meadowbrook State Parkway



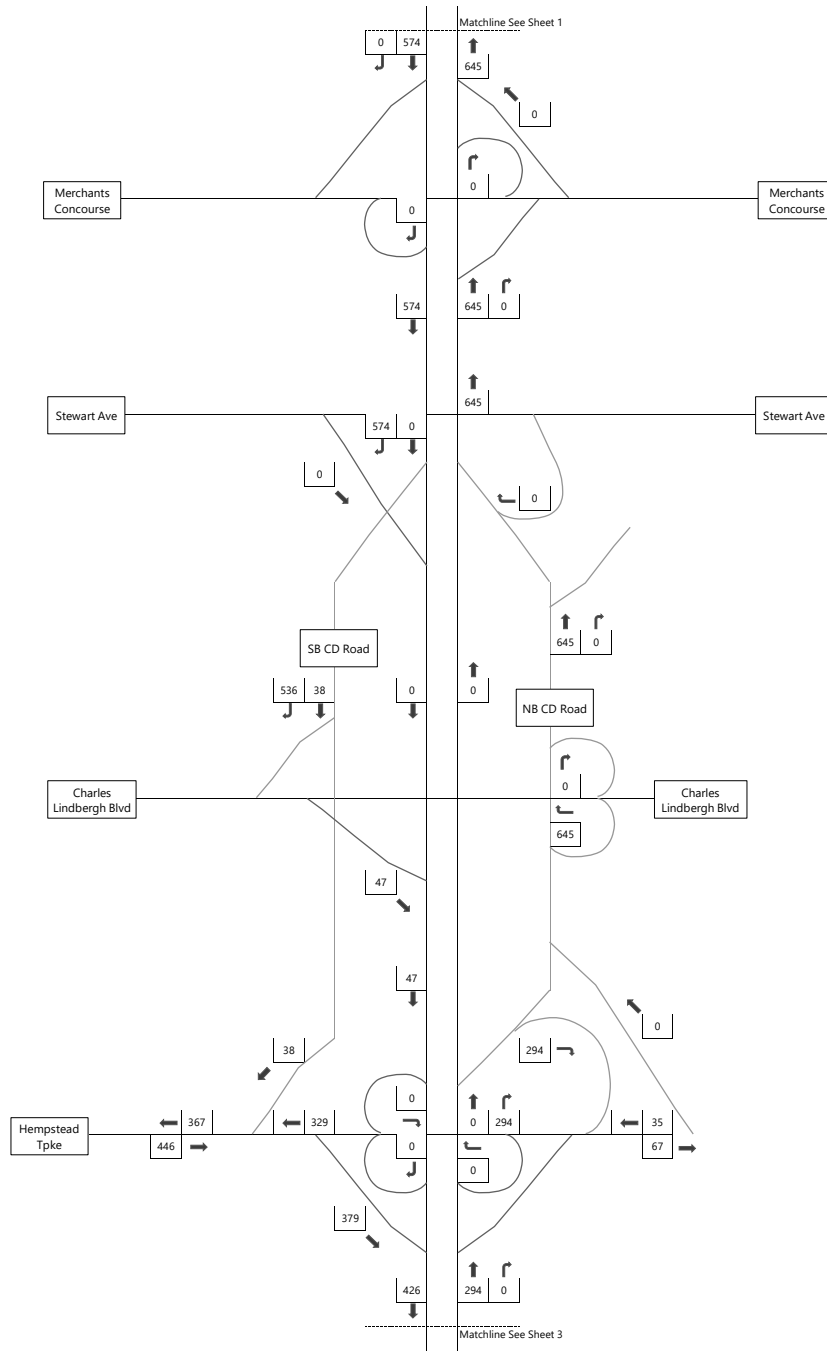

Figure V-D-2, Sheet 2
 2030 Combined Trip Assignment
 Weekday PM Peak Hour
 26841.01 - Sands New York Integrated Resort
 Meadowbrook State Parkway



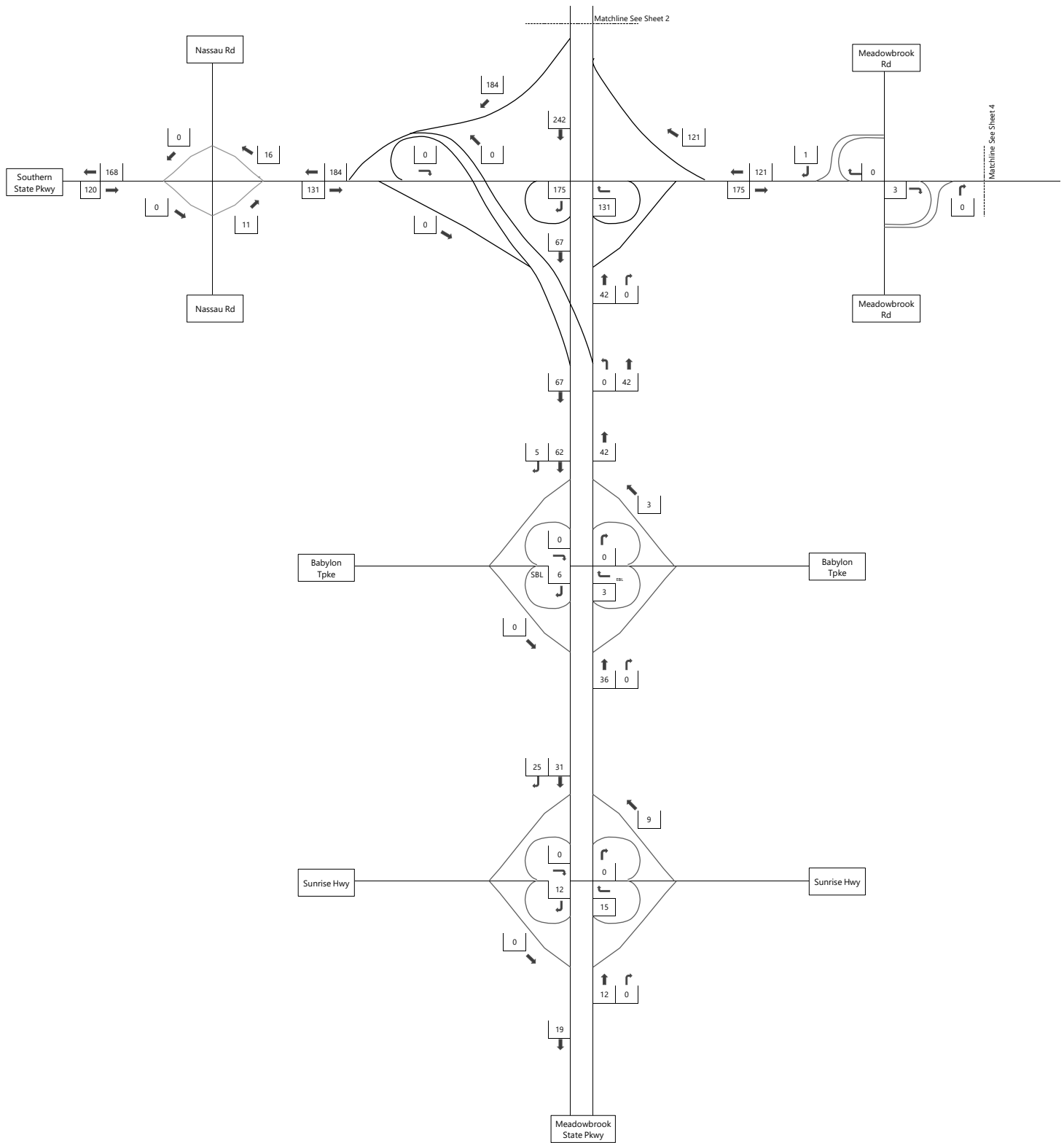

Figure V-D-2, Sheet 3
 2030 Combined Trip Assignment
 Weekday PM Peak Hour
 26841.01 - Sands New York Integrated Resort
 Meadowbrook State Parkway



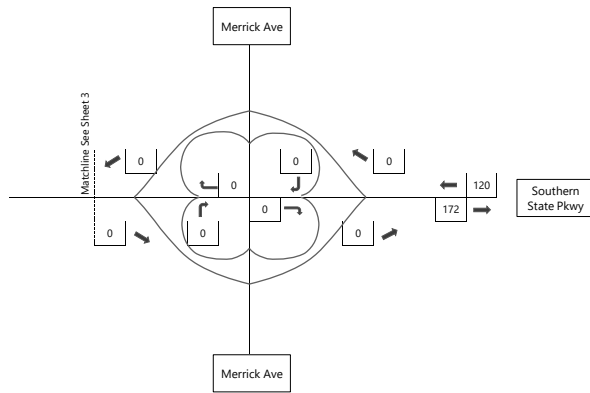
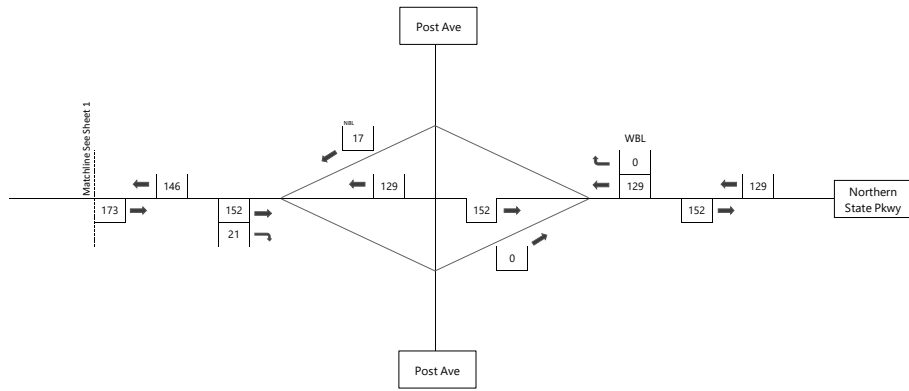

Figure V-D-2, Sheet 4
 2030 Combined Trip Assignment
 Weekday PM Peak Hour
 26841.01 - Sands New York Integrated Resort
 Meadowbrook State Parkway



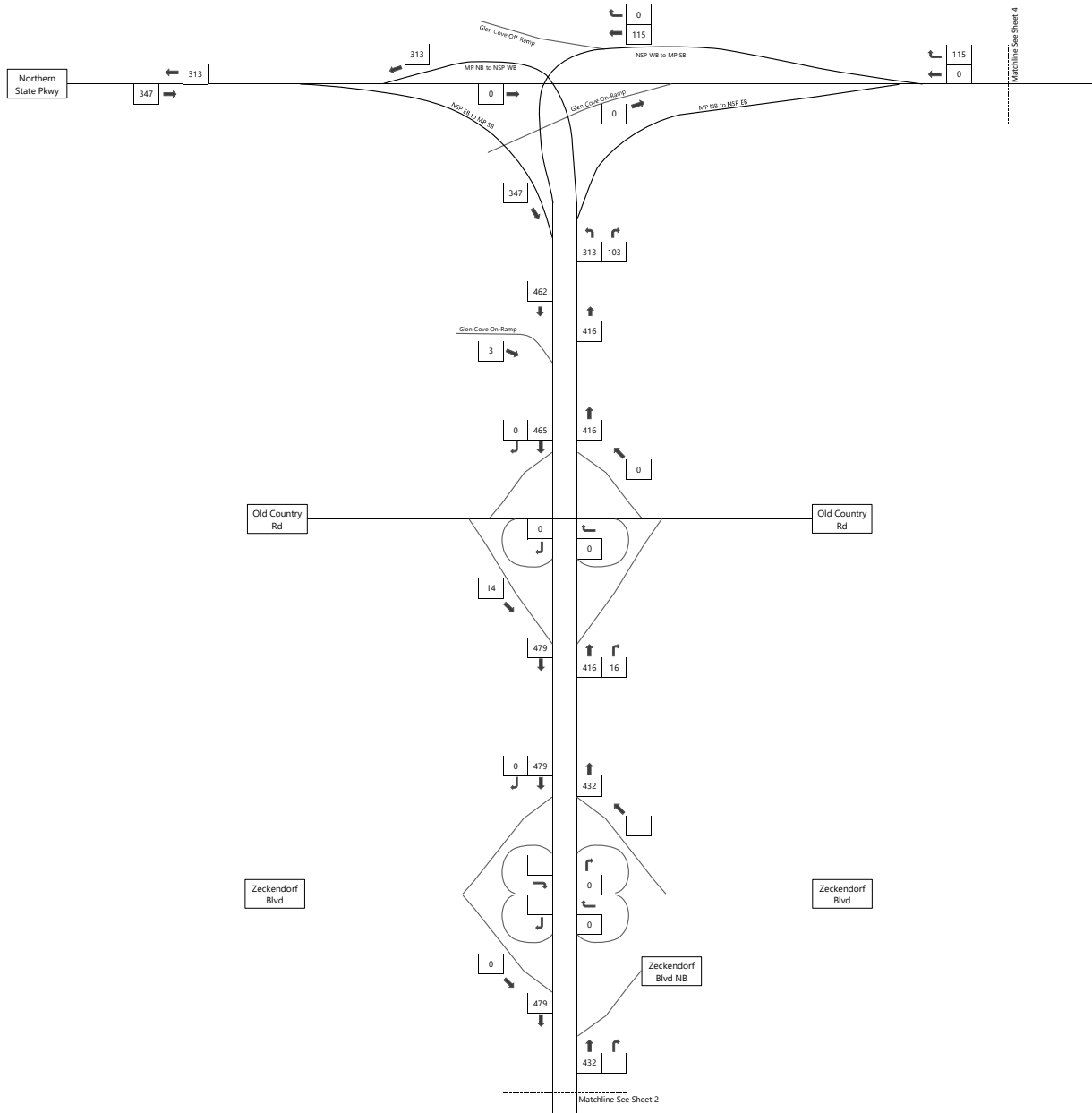

Figure V-D-2-1, Sheet 1
 2030 Trip Assignment - Casino/Hotel
 Weekday PM Peak Hour
 26841.01 - Sands New York Integrated Resort
 Meadowbrook State Parkway



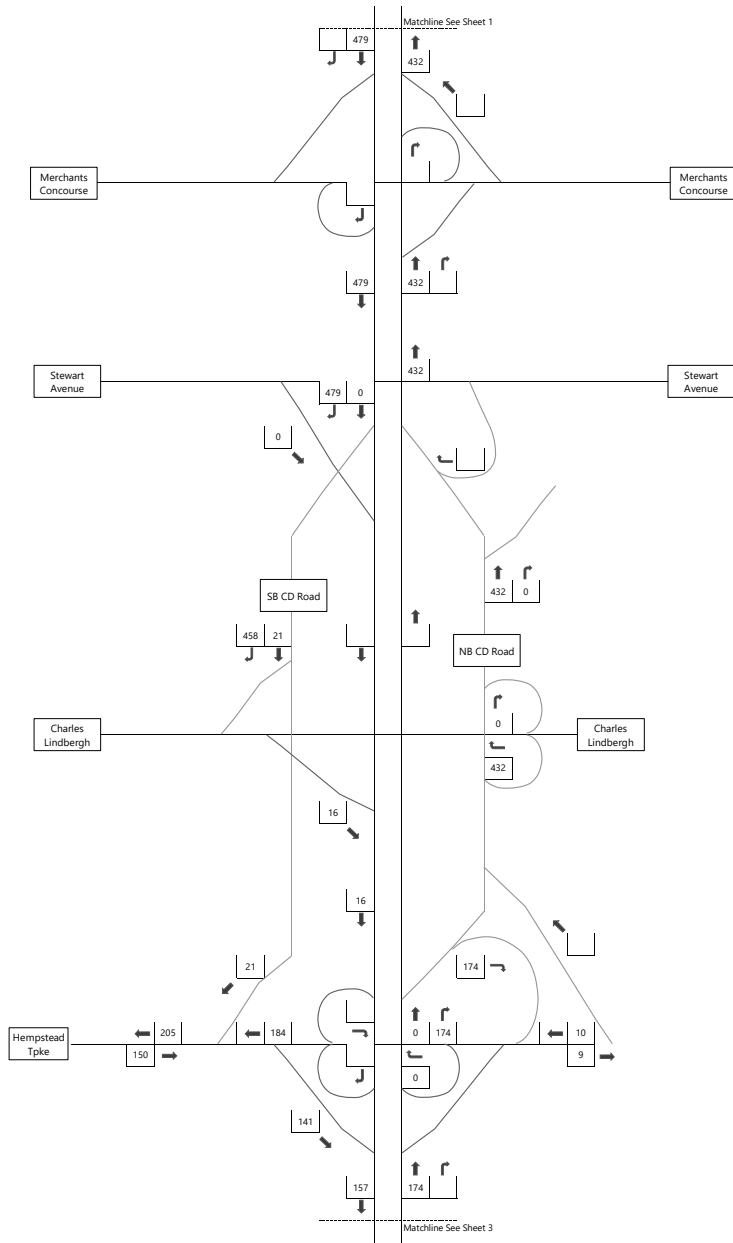

Figure V-D-2-1, Sheet 2
 2030 Trip Assignment - Casino/Hotel
 Weekday PM Peak Hour
 26841.01 - Sands New York Integrated Resort
 Meadowbrook State Parkway



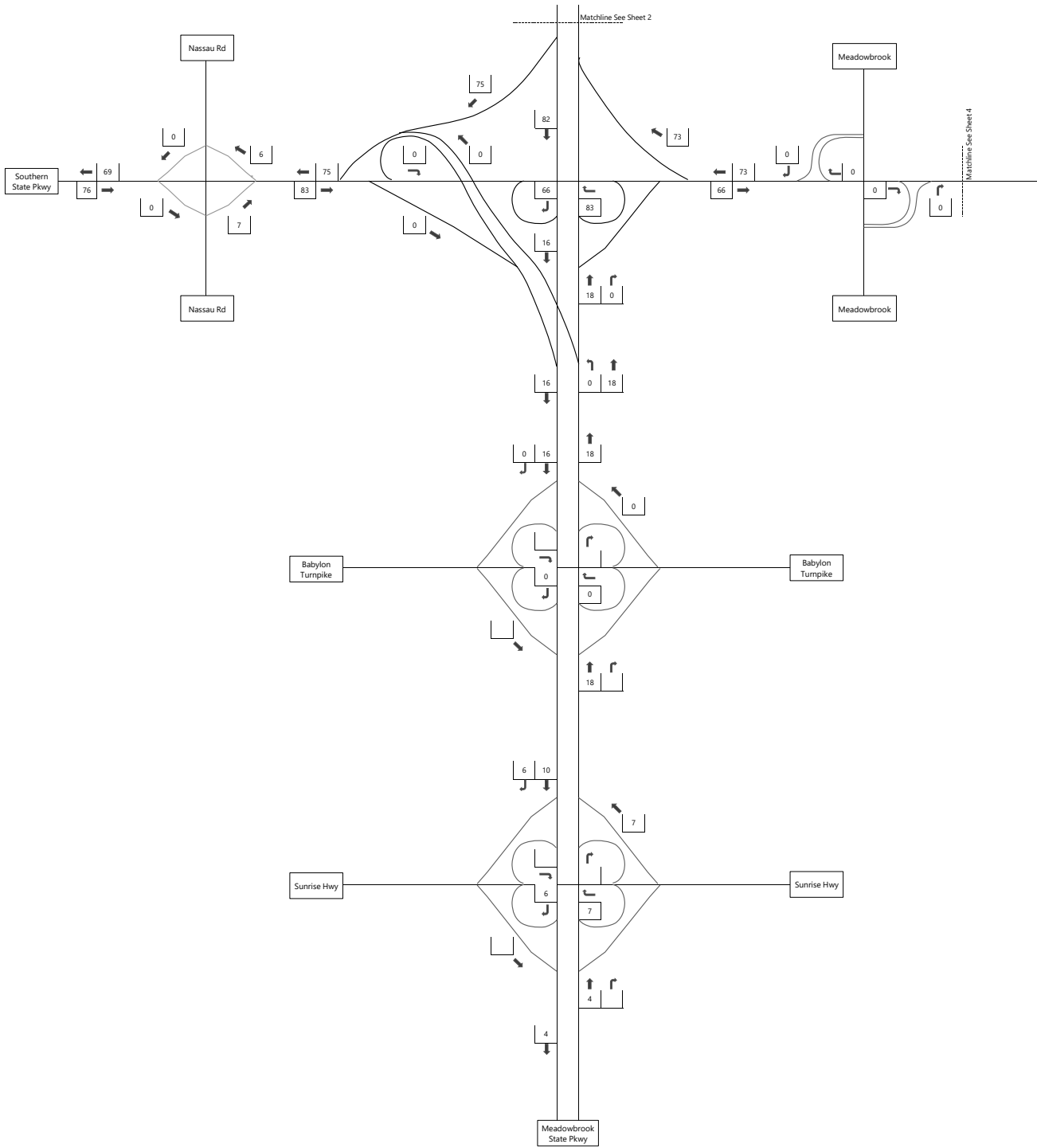

Figure V-D-2-1, Sheet 3
 2030 Trip Assignment - Casino/Hotel
 Weekday PM Peak Hour
 26841.01 - Sands New York Integrated Resort
 Meadowbrook State Parkway



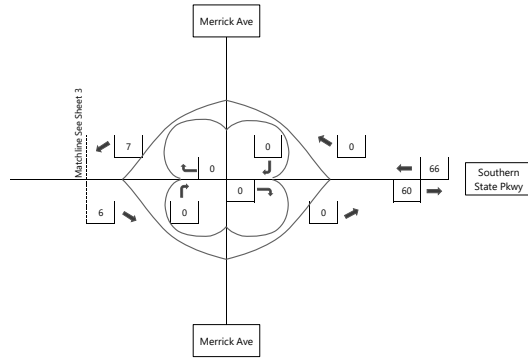
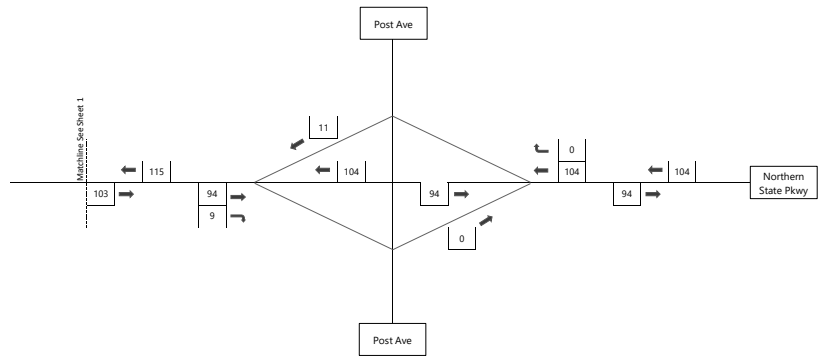

Figure V-D-2-1, Sheet 4
 2030 Trip Assignment - Casino/Hotel
 Weekday PM Peak Hour
 26841.01 - Sands New York Integrated Resort
 Meadowbrook State Parkway



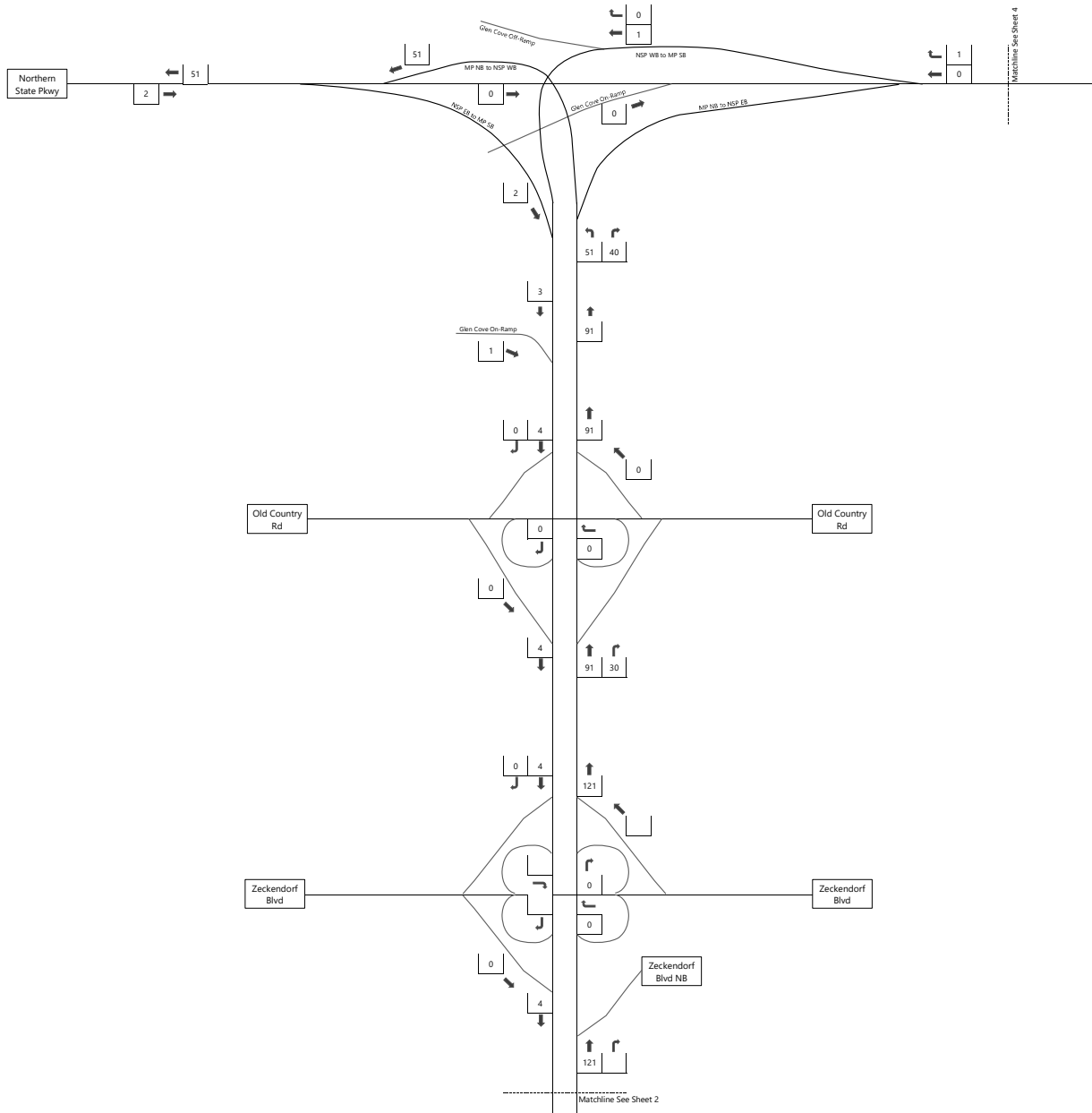

Figure V-D-2-2, Sheet 1
 2030 Trip Assignment - Employee
 Weekday PM Peak Hour
 26841.01 - Sands New York Integrated Resort
 Meadowbrook State Parkway



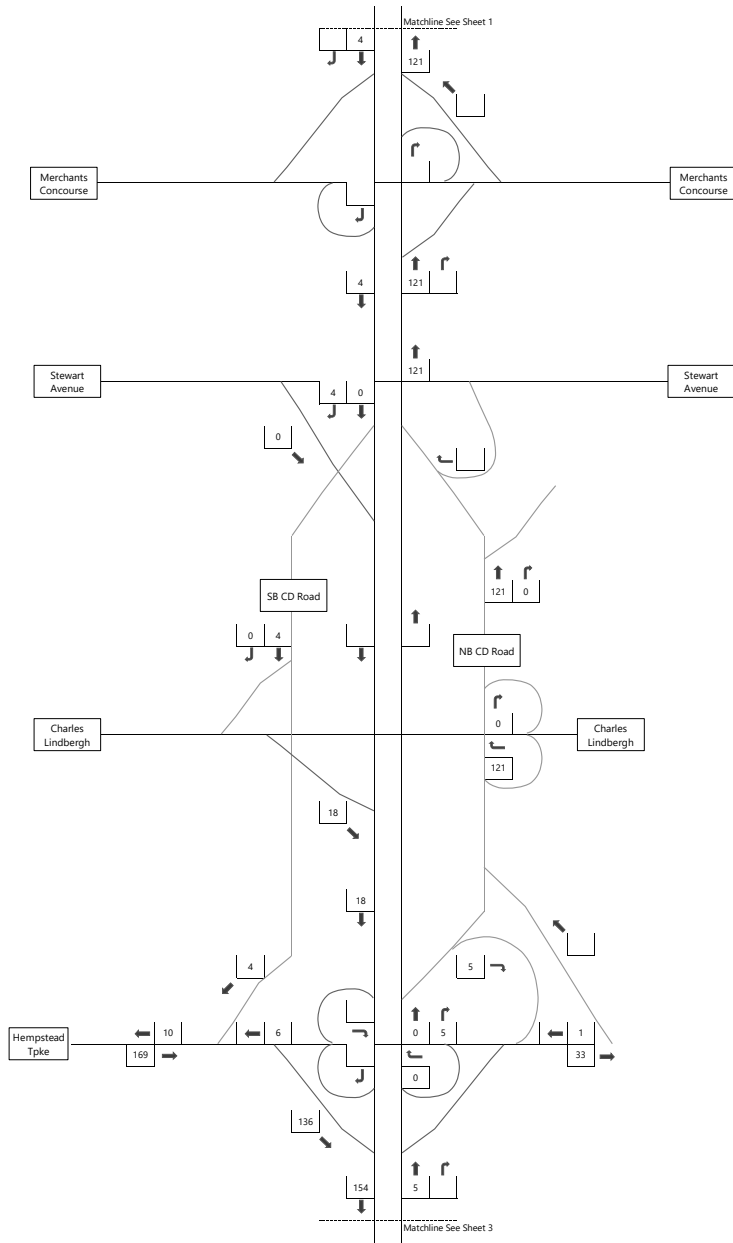

Figure V-D-2-2, Sheet 2
 2030 Trip Assignment - Employee
 Weekday PM Peak Hour
 26841.01 - Sands New York Integrated Resort
 Meadowbrook State Parkway



Not to Scale



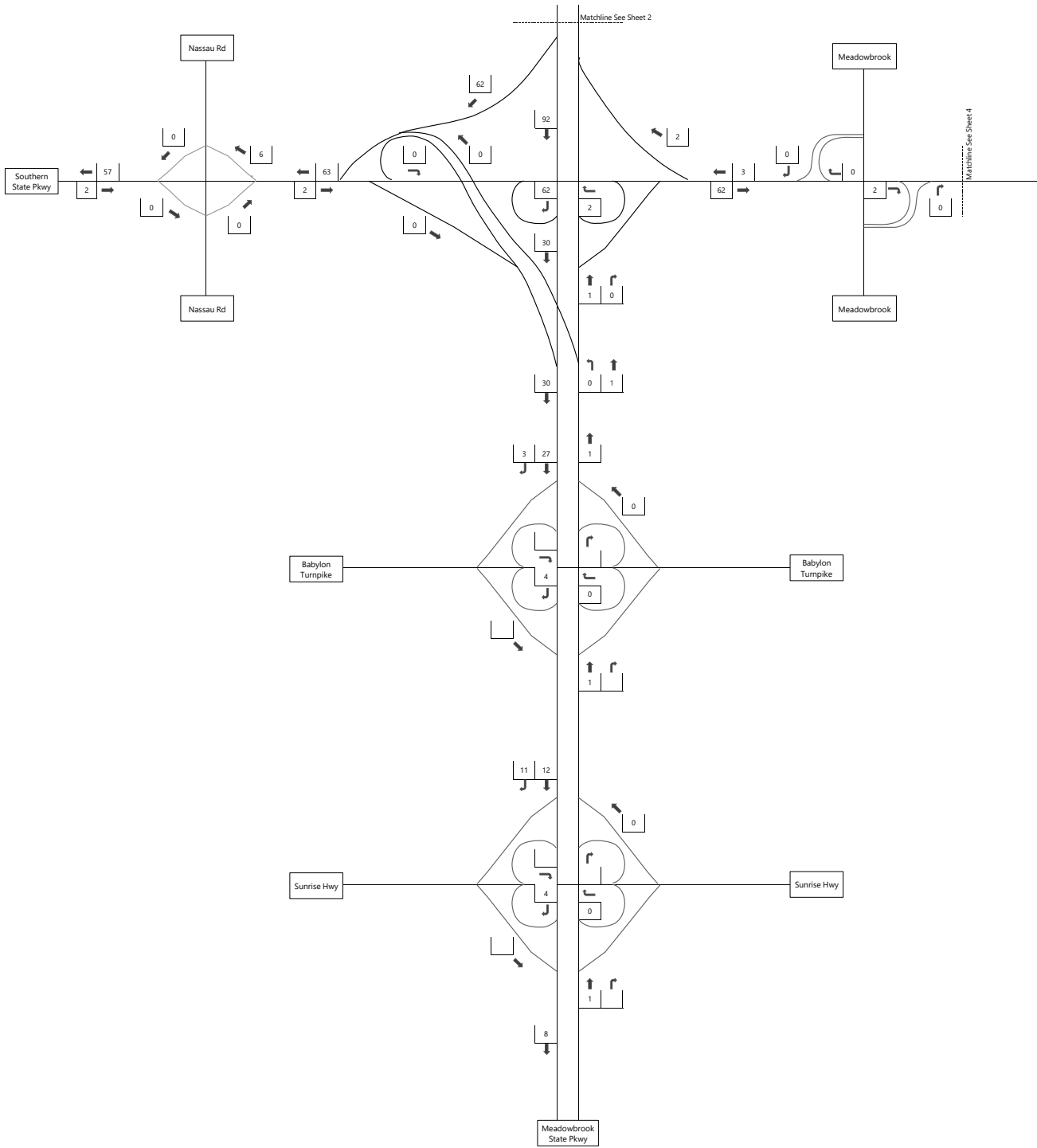

Figure V-D-2-2, Sheet 3
 2030 Trip Assignment - Employee
 Weekday PM Peak Hour
 26841.01 - Sands New York Integrated Resort
 Meadowbrook State Parkway



Not to Scale



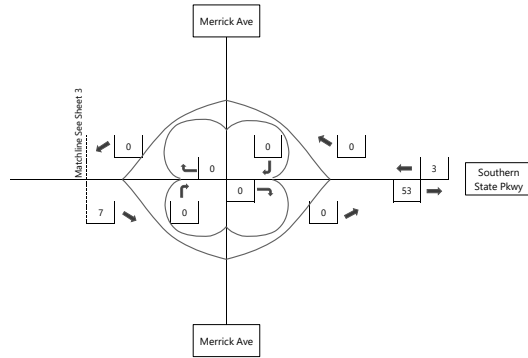
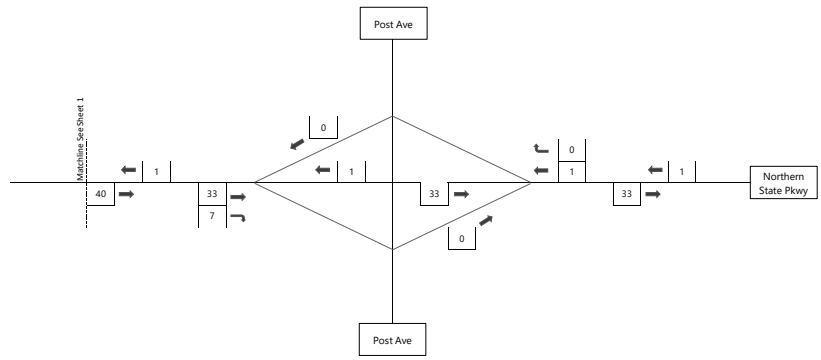

Figure V-D-2-2, Sheet 4
 2030 Trip Assignment - Employee
 Weekday PM Peak Hour
 26841.01 - Sands New York Integrated Resort
 Meadowbrook State Parkway



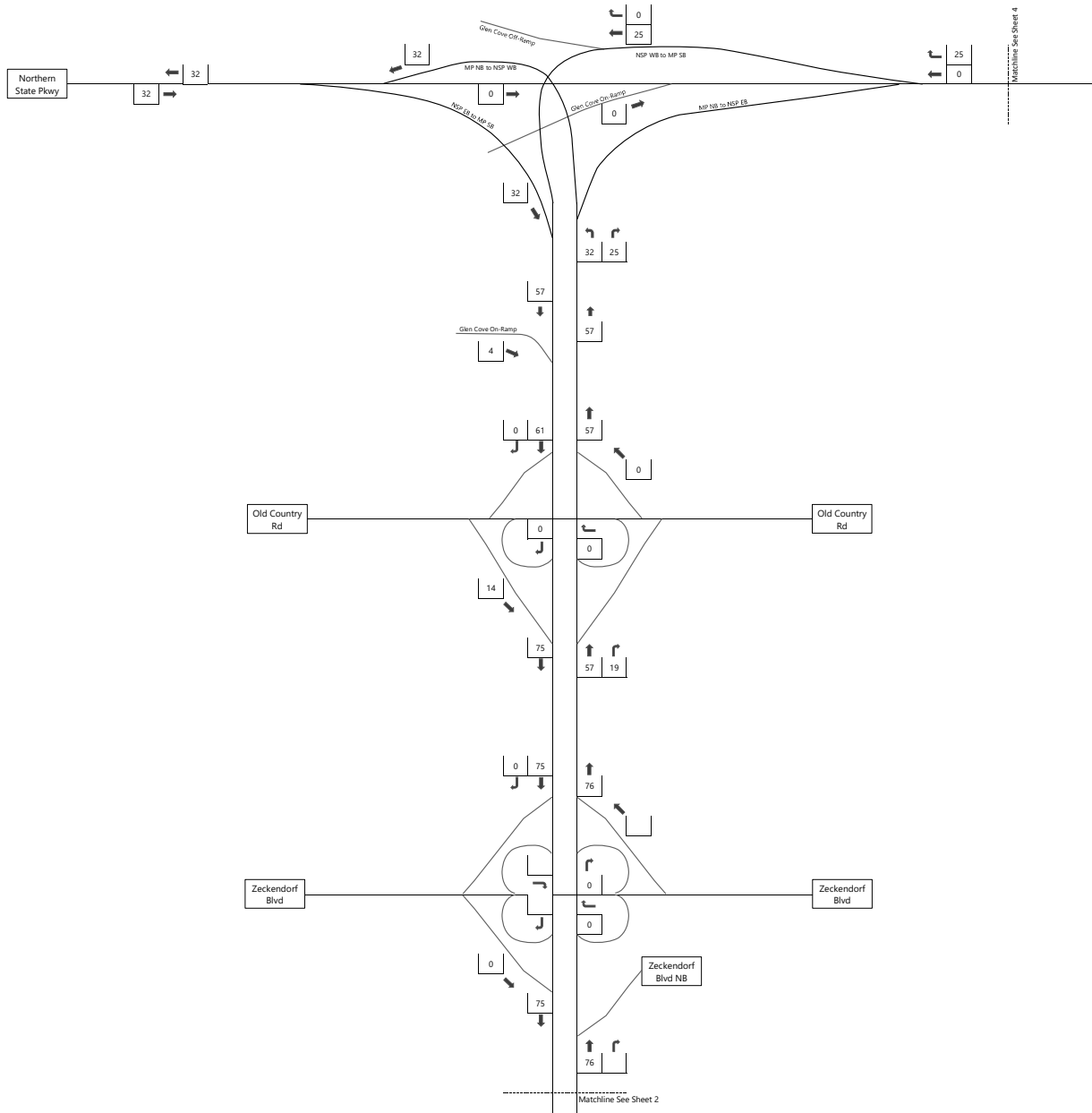

Figure V-D-2-3, Sheet 1
 2030 Trip Assignment - Restaurant/Retail/Public Attraction,
 Theater, Meetings and Conference
 Weekday PM Peak Hour
 26841.01 - Sands New York Integrated Resort
 Meadowbrook State Parkway



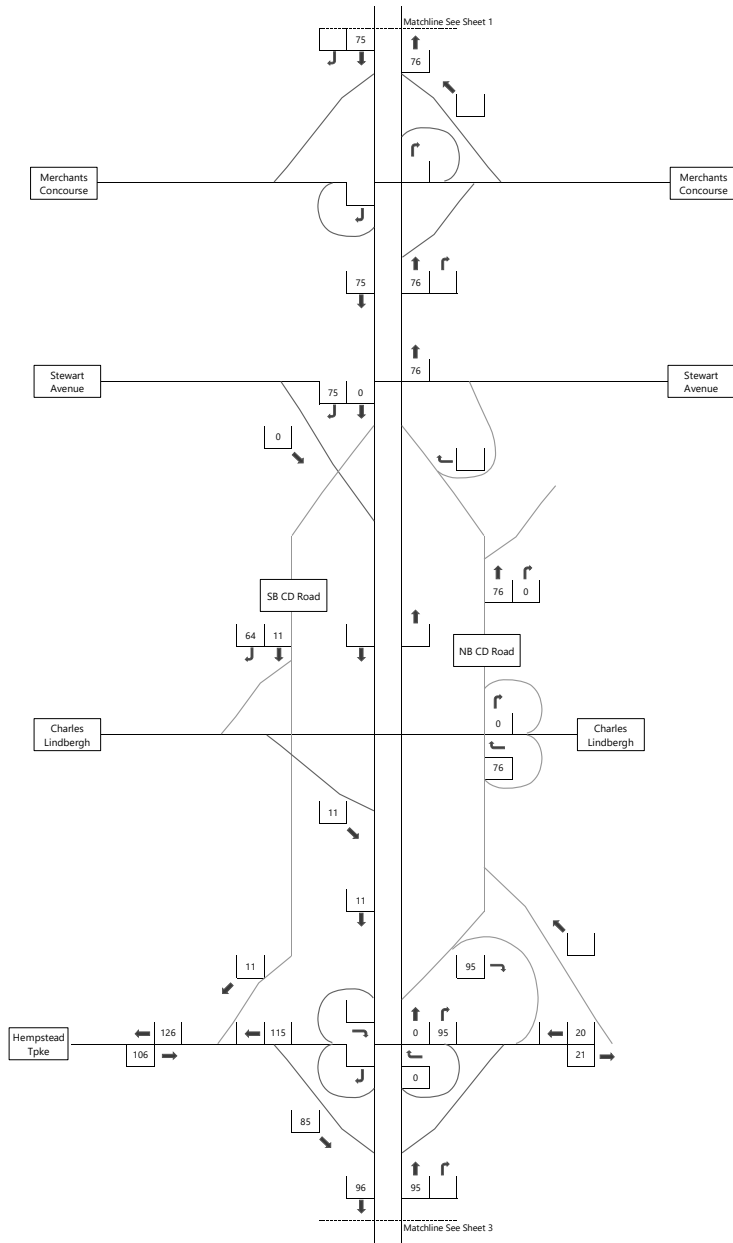

Figure V-D-2-3, Sheet 2
 2030 Trip Assignment - Restaurant/Retail/Public Attraction,
 Theater, Meetings and Conference
 Weekday PM Peak Hour
 26841.01 - Sands New York Integrated Resort
 Meadowbrook State Parkway



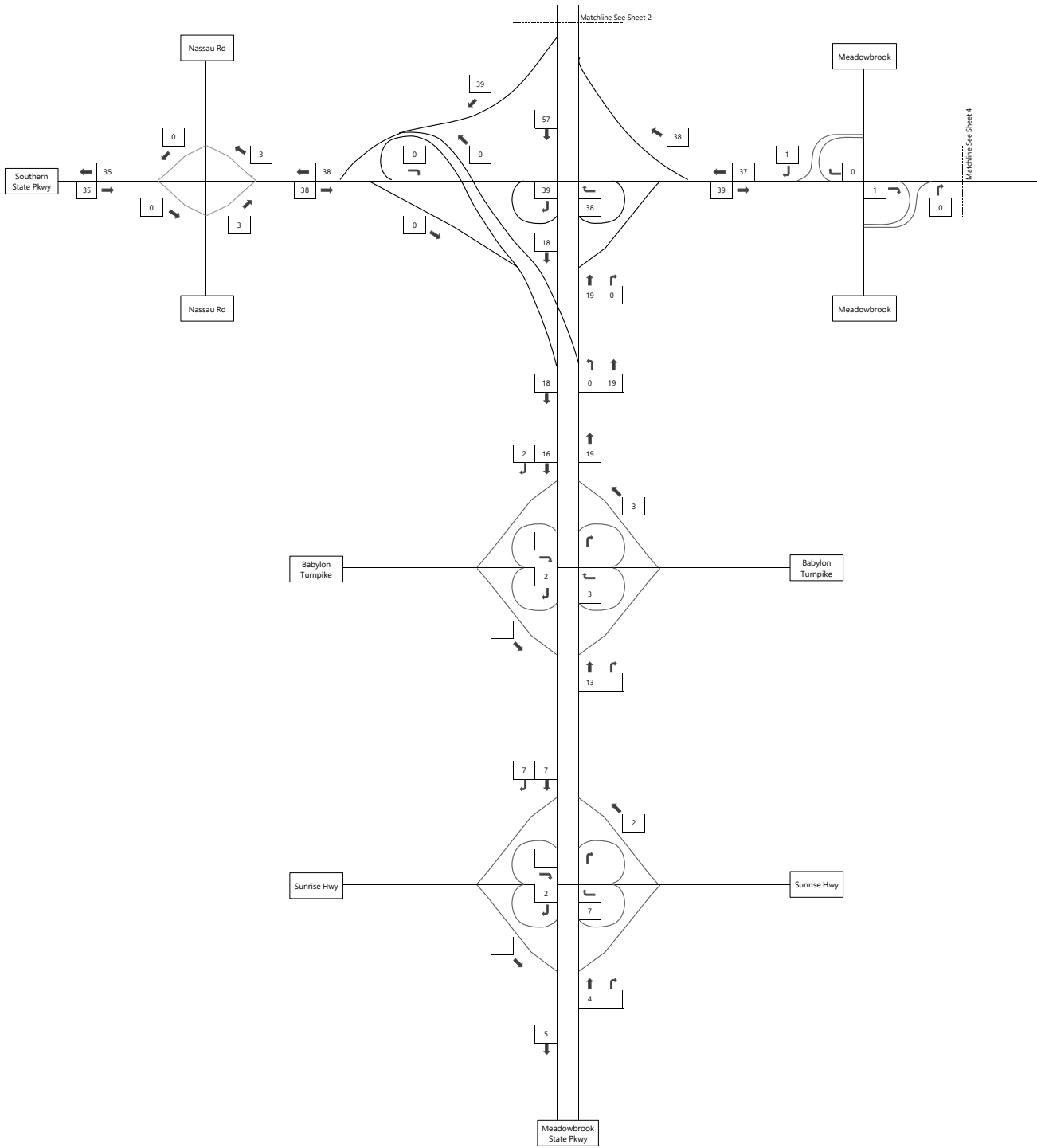

Figure V-D-2-3, Sheet 3
 2030 Trip Assignment - Restaurant/Retail/Public Attraction,
 Theater, Meetings and Conference
 Weekday PM Peak Hour
 26841.01 - Sands New York Integrated Resort
 Meadowbrook State Parkway



Not to Scale



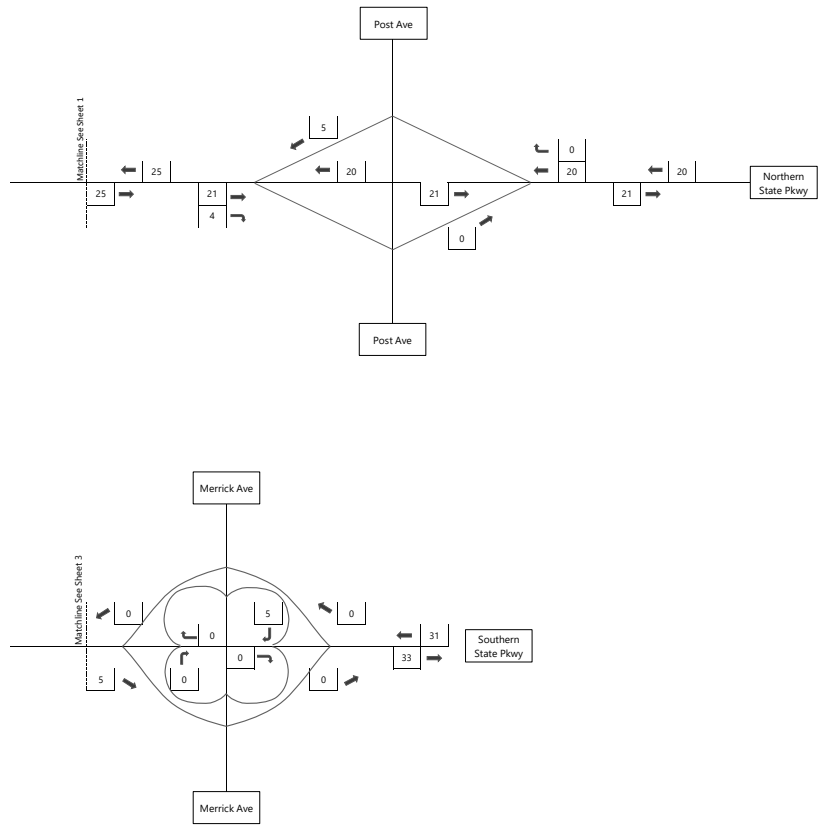

Figure V-D-2-3, Sheet 4
 2030 Trip Assignment - Restaurant/Retail/Public Attraction,
 Theater, Meetings and Conference
 Weekday PM Peak Hour
 26841.01 - Sands New York Integrated Resort
 Meadowbrook State Parkway



Not to Scale



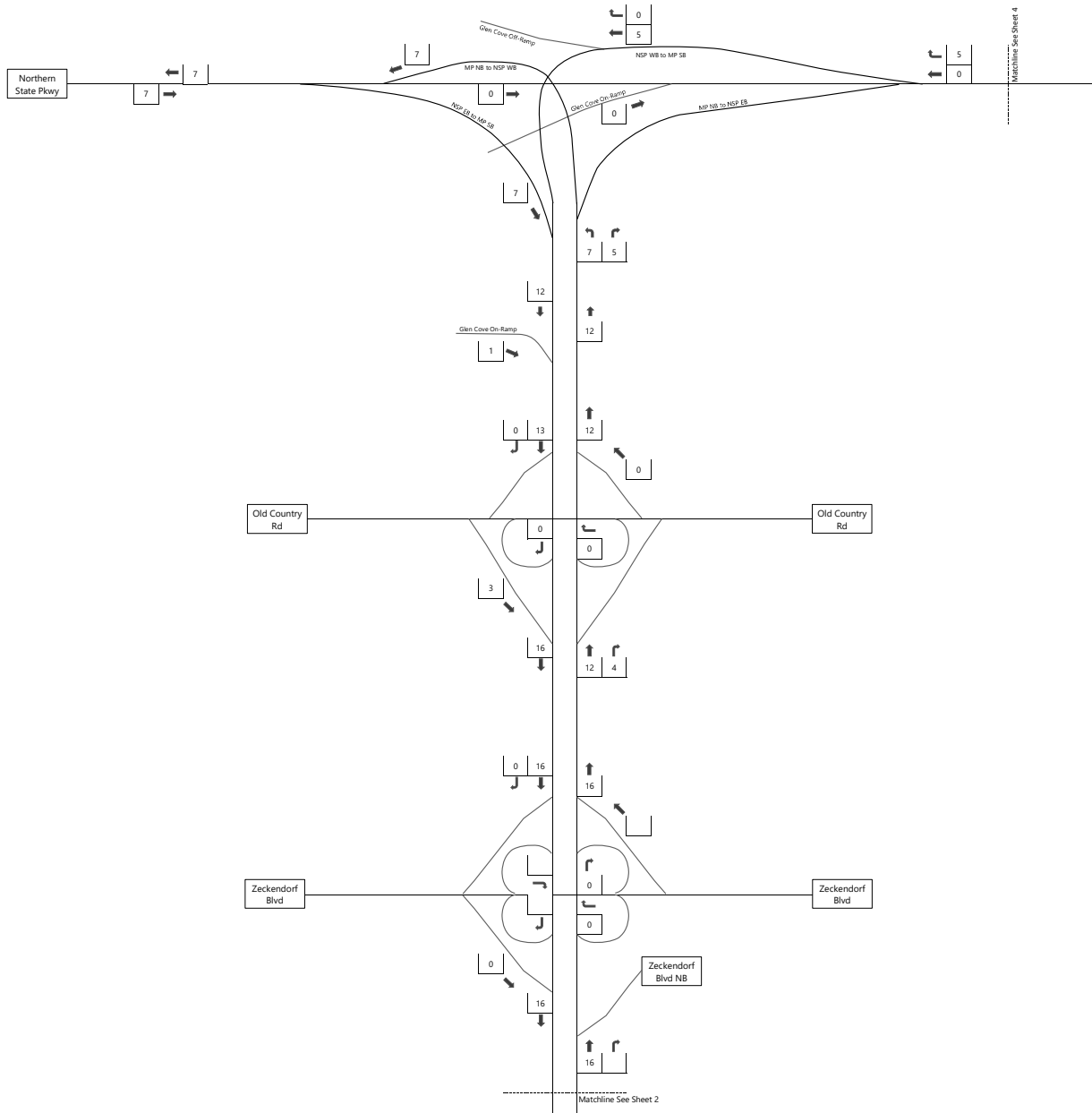

Figure V-D-2-4, Sheet 1
 2030 Trip Assignment - Ridehailing
 Weekday PM Peak Hour
 26841.01 - Sands New York Integrated Resort
 Meadowbrook State Parkway



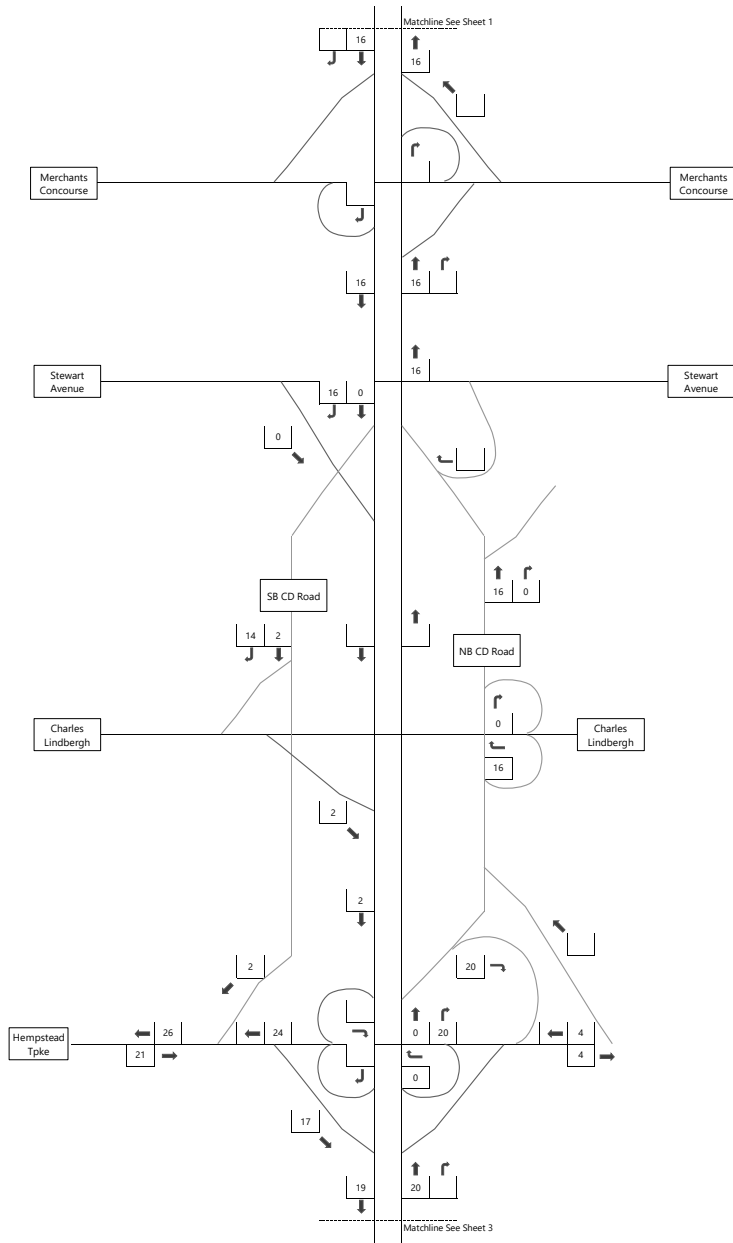

Figure V-D-2-4, Sheet 2
 2030 Trip Assignment - Ridehailing
 Weekday PM Peak Hour
 26841.01 - Sands New York Integrated Resort
 Meadowbrook State Parkway



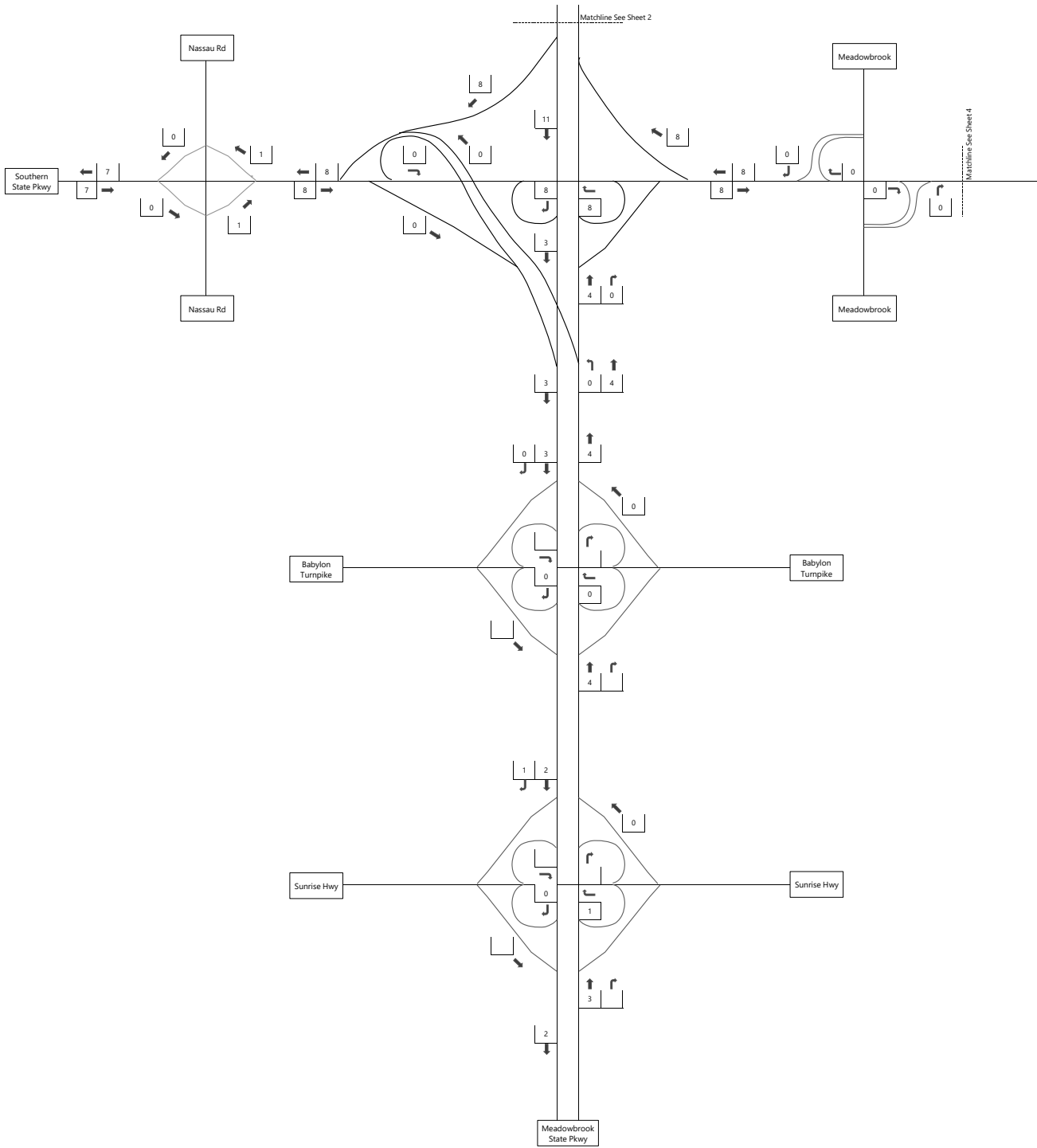

Figure V-D-2-4, Sheet 3
 2030 Trip Assignment - Ridehailing
 Weekday PM Peak Hour
 26841.01 - Sands New York Integrated Resort
 Meadowbrook State Parkway



Not to Scale



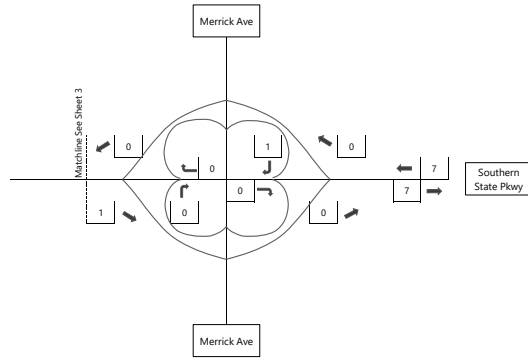
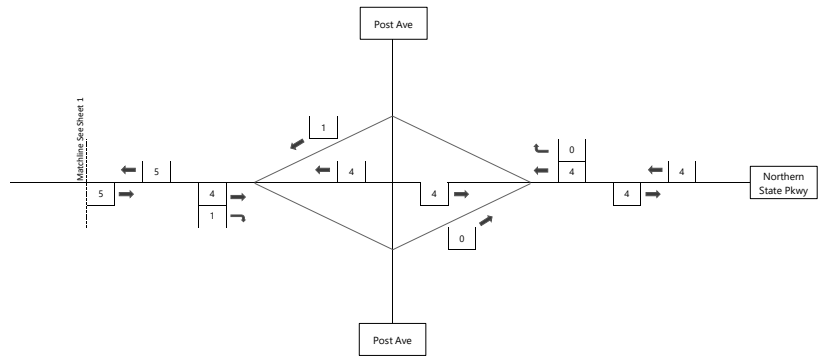

Figure V-D-2-4, Sheet 4
 2030 Trip Assignment - Ridehailing
 Weekday PM Peak Hour
 26841.01 - Sands New York Integrated Resort
 Meadowbrook State Parkway



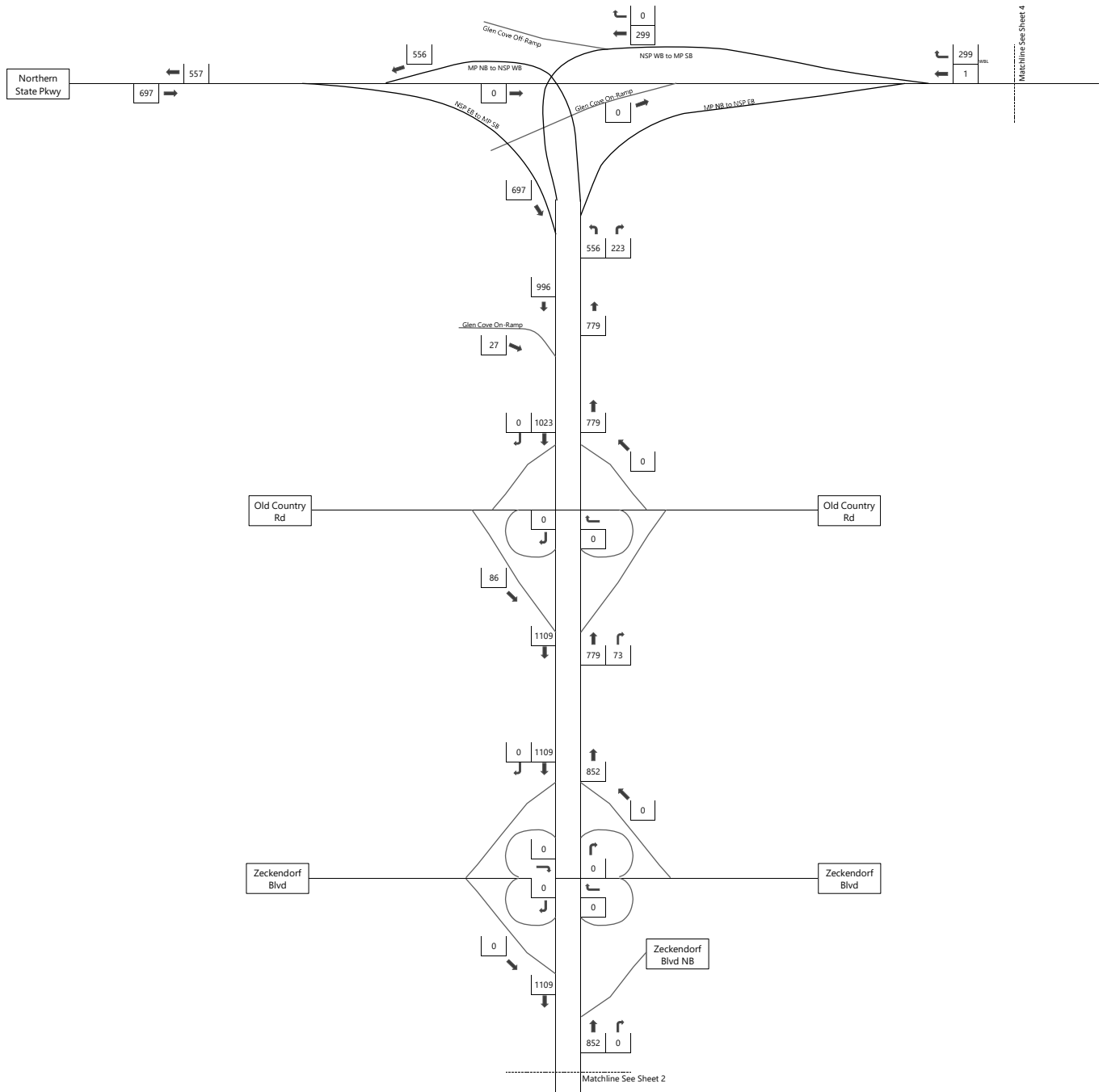

Figure V-D-3, Sheet 1
 2030 Combined Trip Assignment
 Friday Evening Peak Hour
 26841.01 - Sands New York Integrated Resort
 Meadowbrook State Parkway



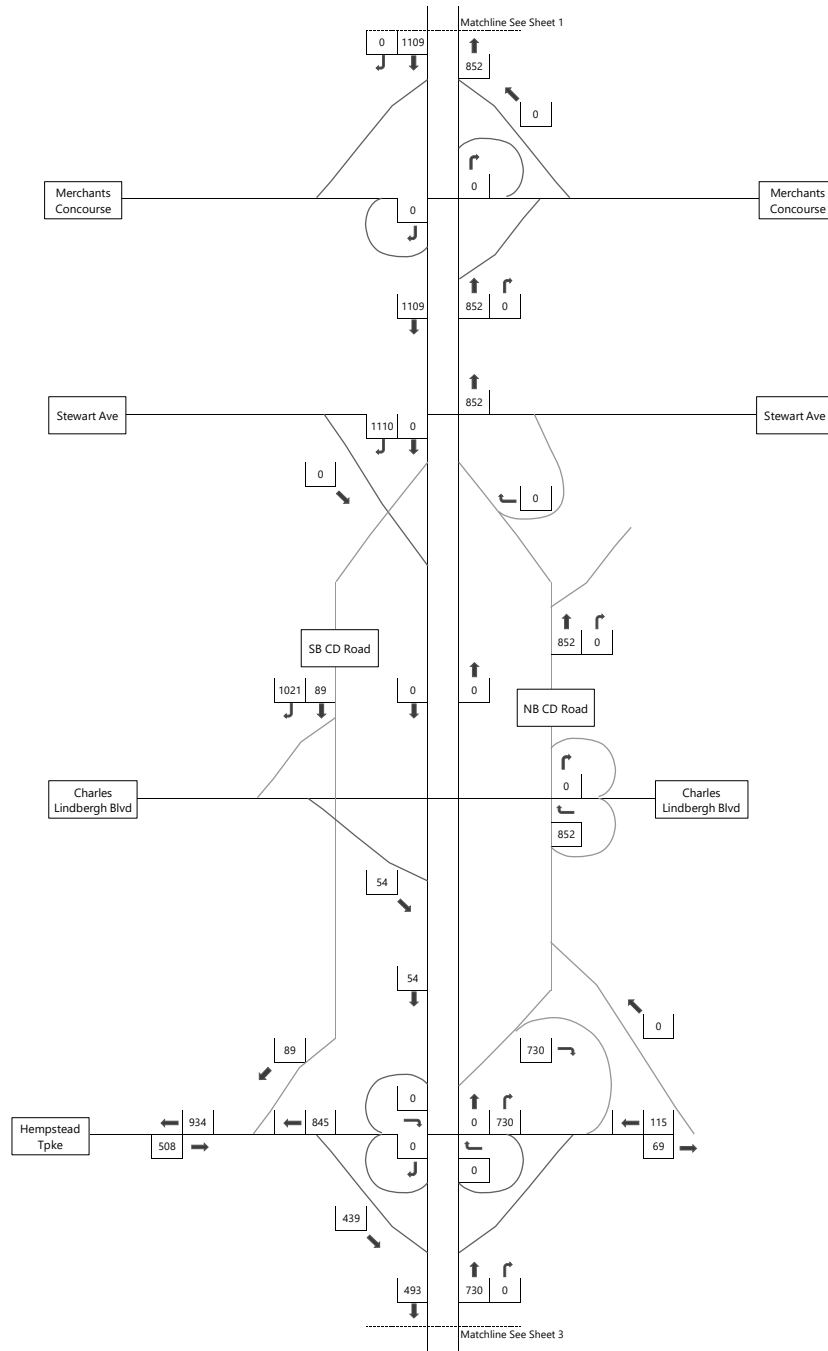

Figure V-D-3, Sheet 2
 2030 Combined Trip Assignment
 Friday Evening Peak Hour
 26841.01 - Sands New York Integrated Resort
 Meadowbrook State Parkway



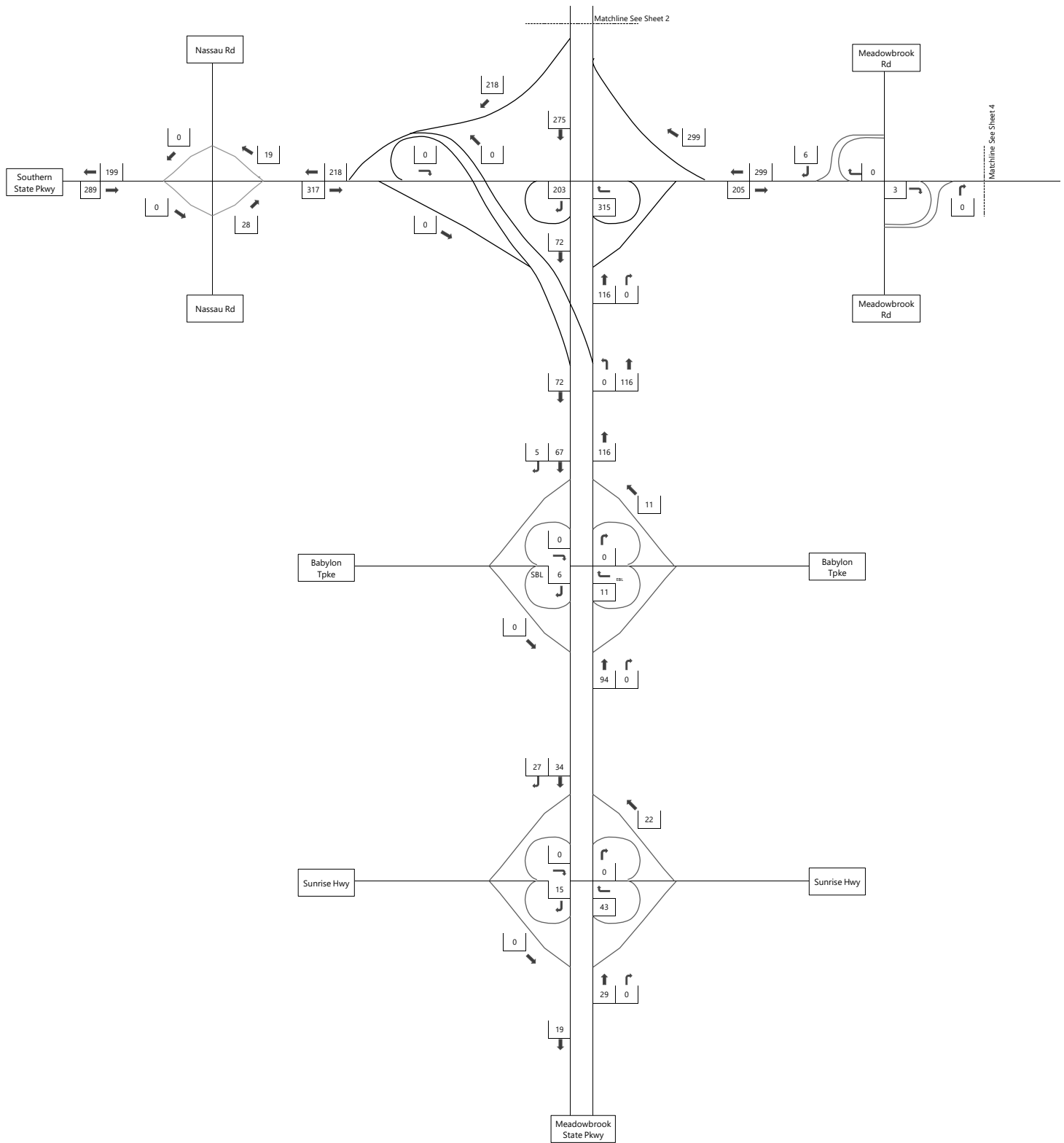

Figure V-D-3, Sheet 3
 2030 Combined Trip Assignment
 Friday Evening Peak Hour
 26841.01 - Sands New York Integrated Resort
 Meadowbrook State Parkway



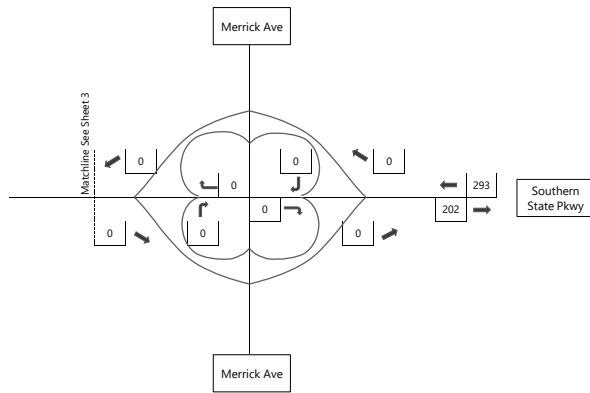
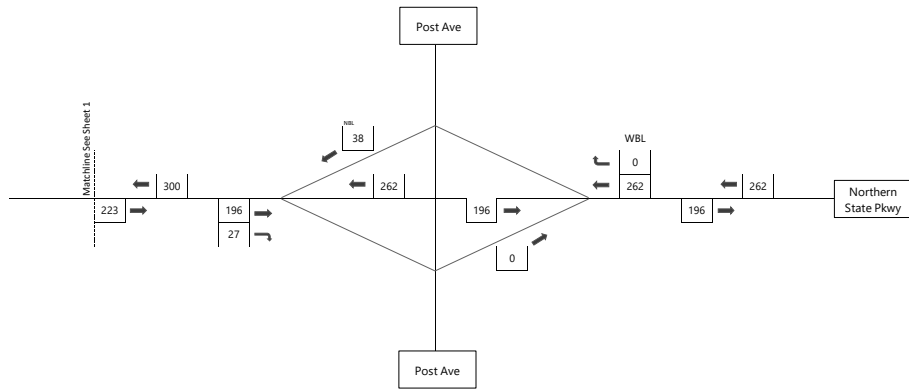

Figure V-D-3, Sheet 4
 2030 Combined Trip Assignment
 Friday Evening Peak Hour
 26841.01 - Sands New York Integrated Resort
 Meadowbrook State Parkway



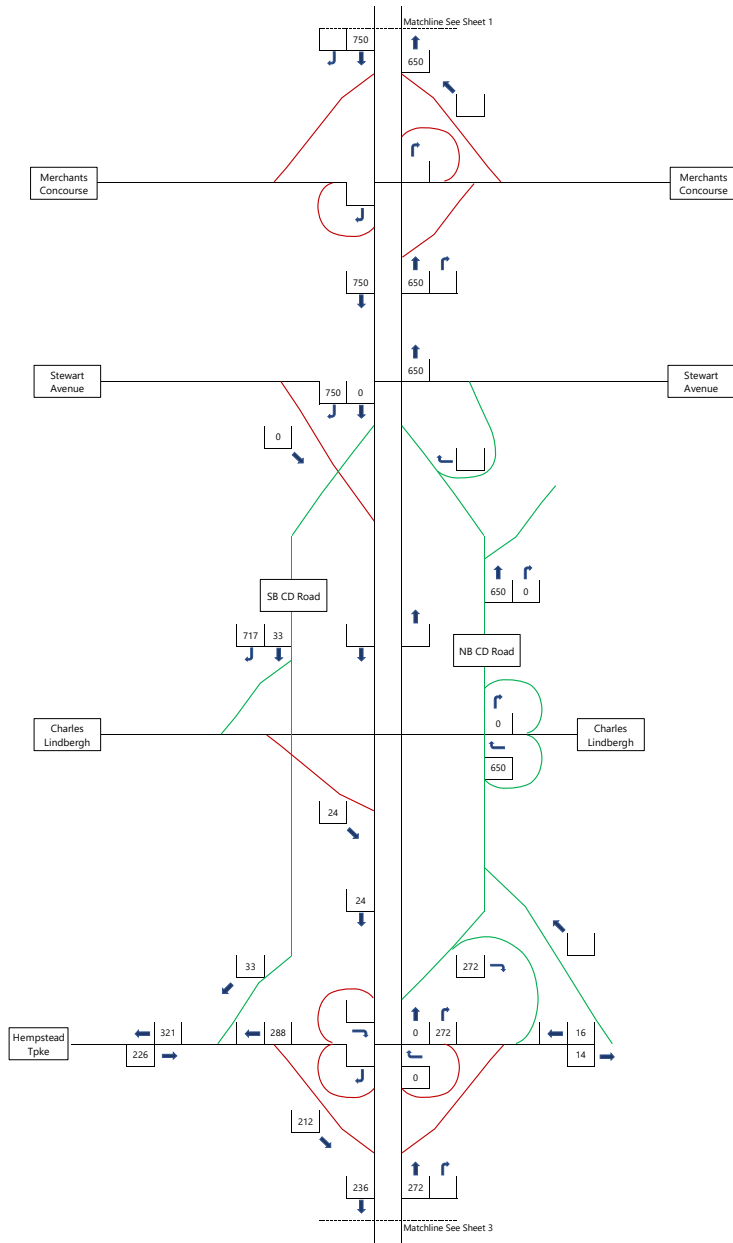

Figure V-D-3-1, Sheet 2
 2030 Trip Assignment - Casino/Hotel
 Friday Evening Peak Hour
 26841.01 - Sands New York Integrated Resort
 Meadowbrook State Parkway



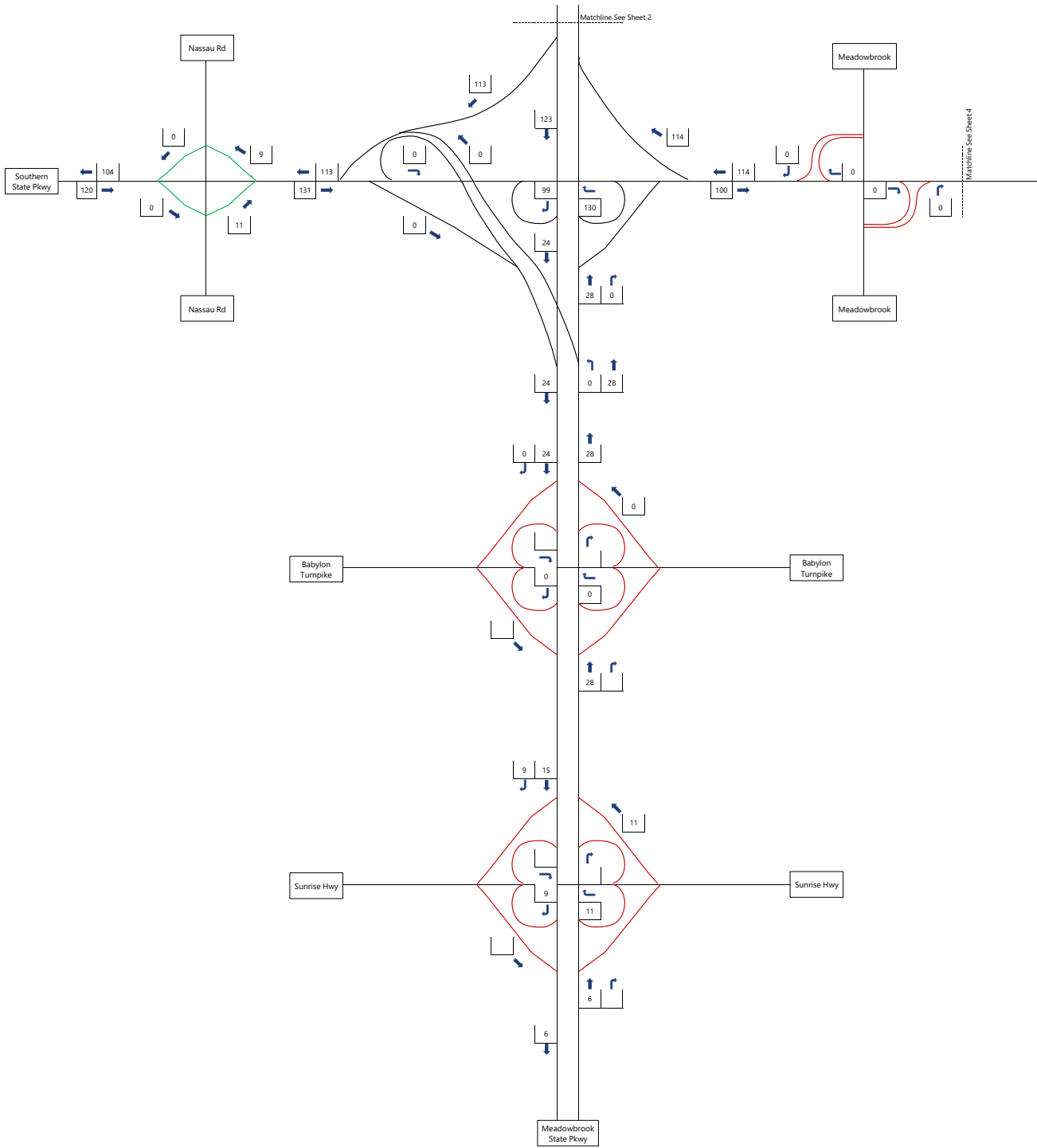

Figure V-D-3-1, Sheet 3
 2030 Trip Assignment - Casino/Hotel
 Friday Evening Peak Hour
 26841.01 - Sands New York Integrated Resort
 Meadowbrook State Parkway



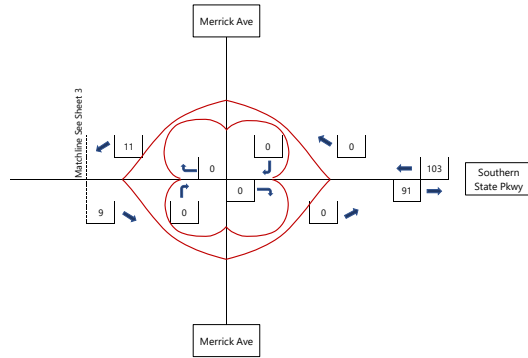
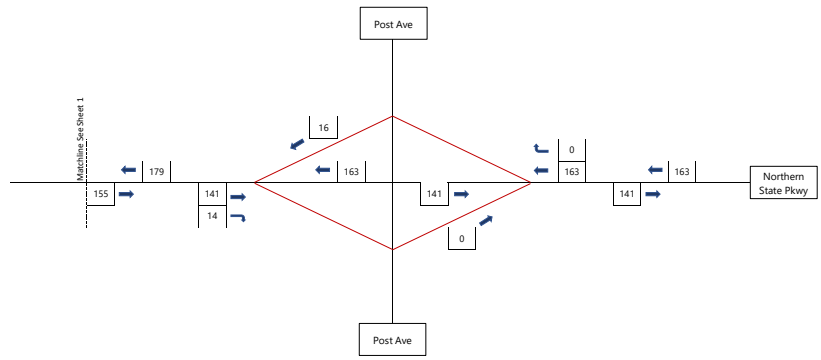

Figure V-D-3-1, Sheet 4
 2030 Trip Assignment - Casino/Hotel
 Friday Evening Peak Hour
 26841.01 - Sands New York Integrated Resort
 Meadowbrook State Parkway



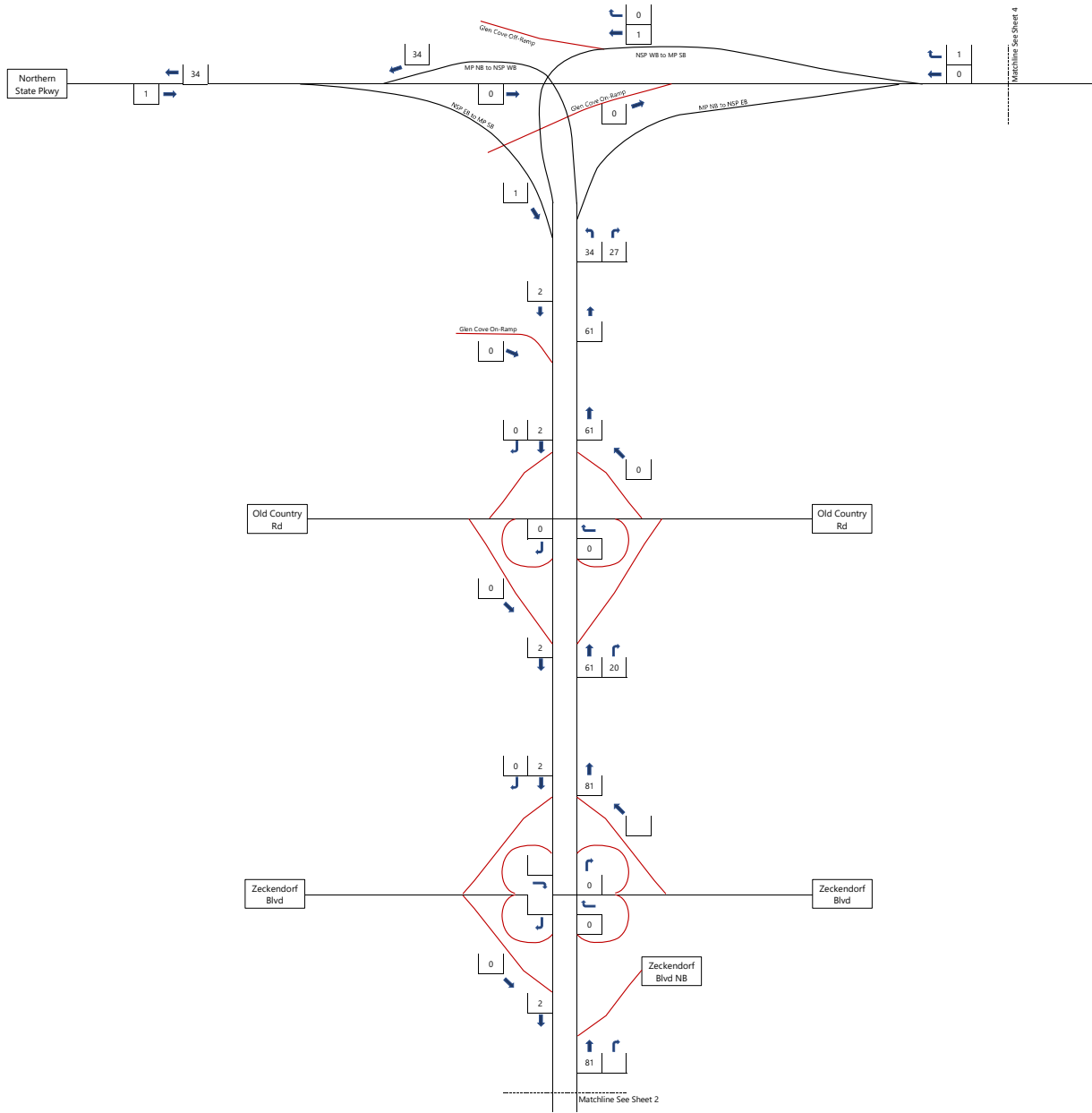

Figure V-D-3-2, Sheet 1
 2030 Trip Assignment - Employee
 Friday Evening Peak Hour
 26841.01 - Sands New York Integrated Resort
 Meadowbrook State Parkway



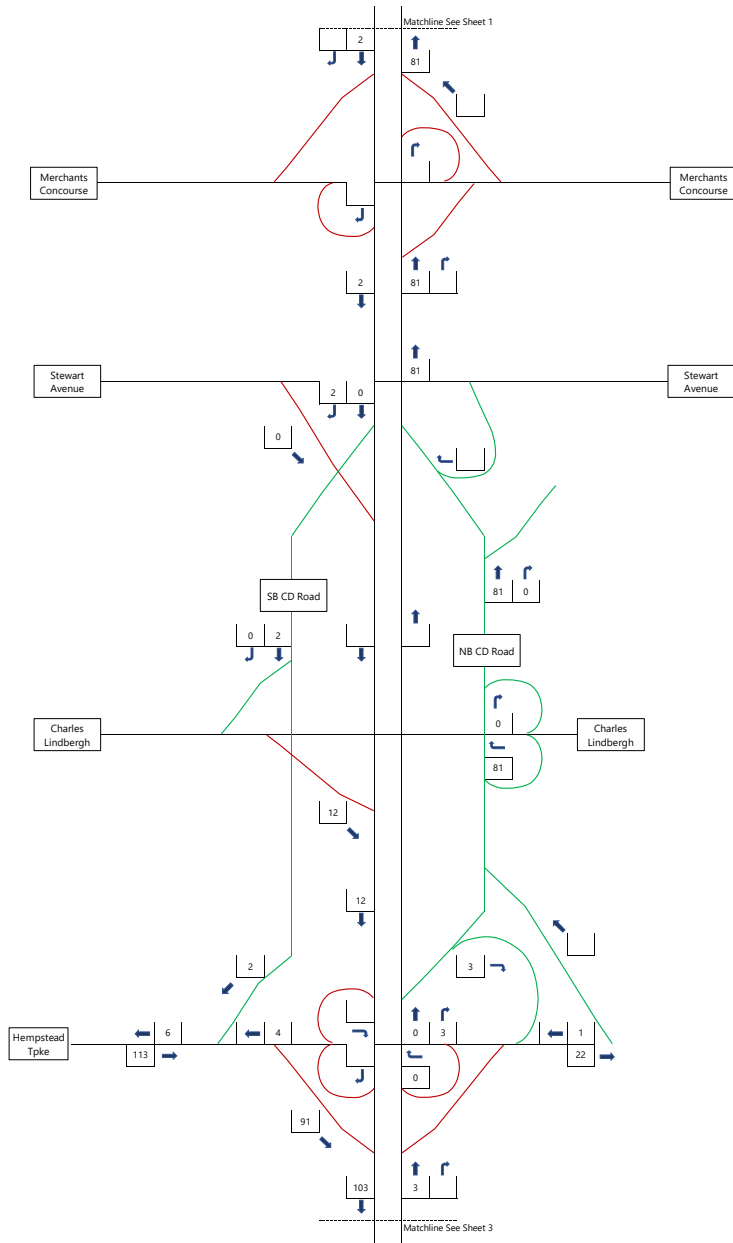

Figure V-D-3-2, Sheet 2
 2030 Trip Assignment - Employee
 Friday Evening Peak Hour
 26841.01 - Sands New York Integrated Resort
 Meadowbrook State Parkway



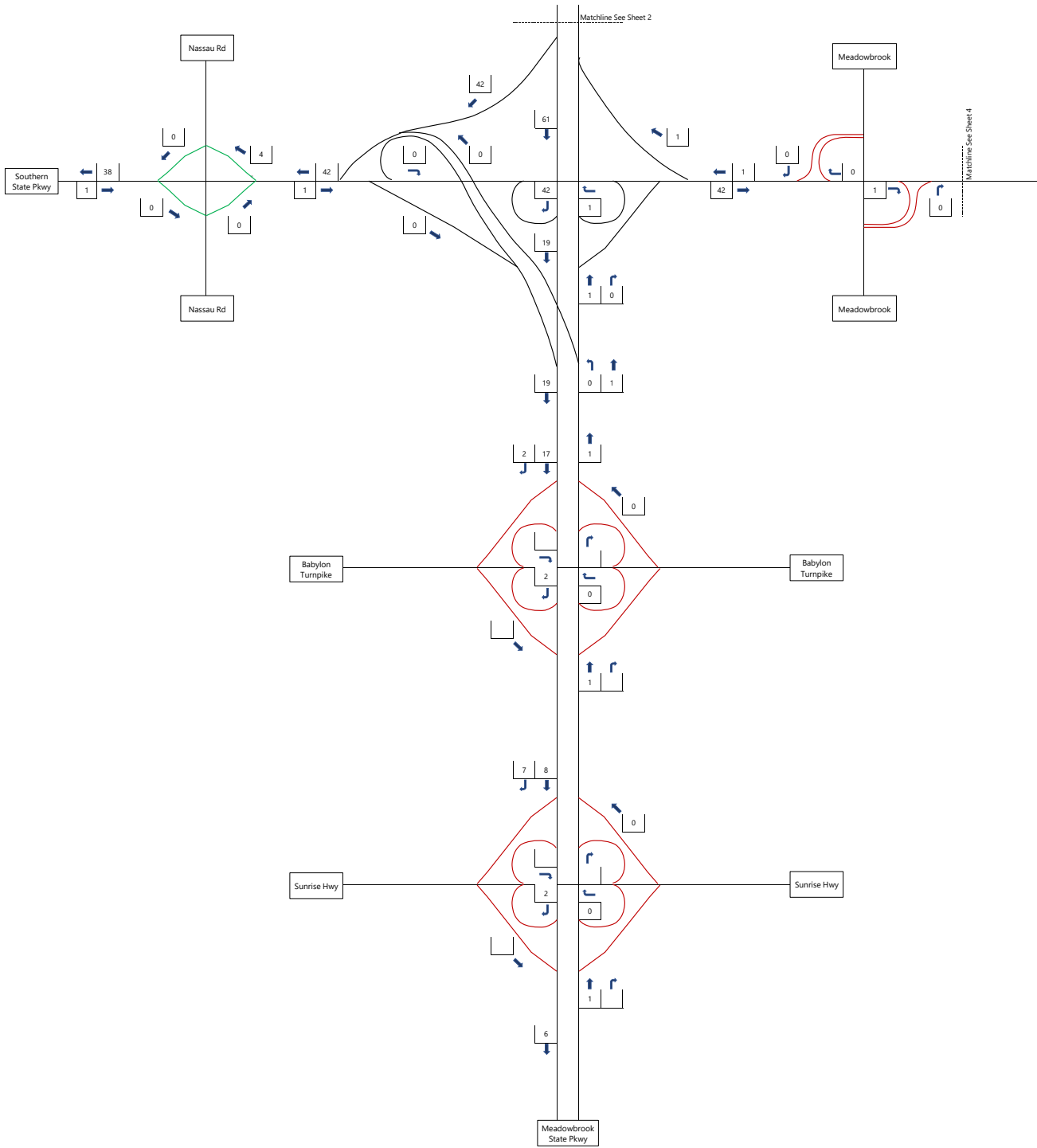

Figure V-D-3-2, Sheet 3
 2030 Trip Assignment - Employee
 Friday Evening Peak Hour
 26841.01 - Sands New York Integrated Resort
 Meadowbrook State Parkway



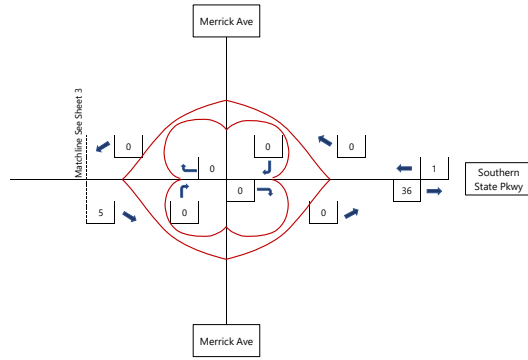
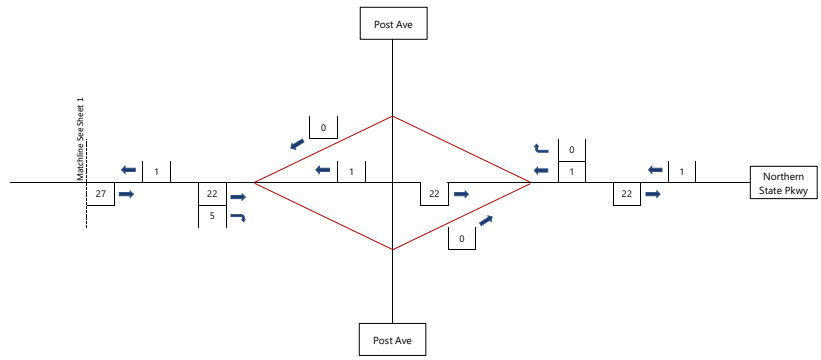

Figure V-D-3-2, Sheet 4
 2030 Trip Assignment - Employee
 Friday Evening Peak Hour
 26841.01 - Sands New York Integrated Resort
 Meadowbrook State Parkway



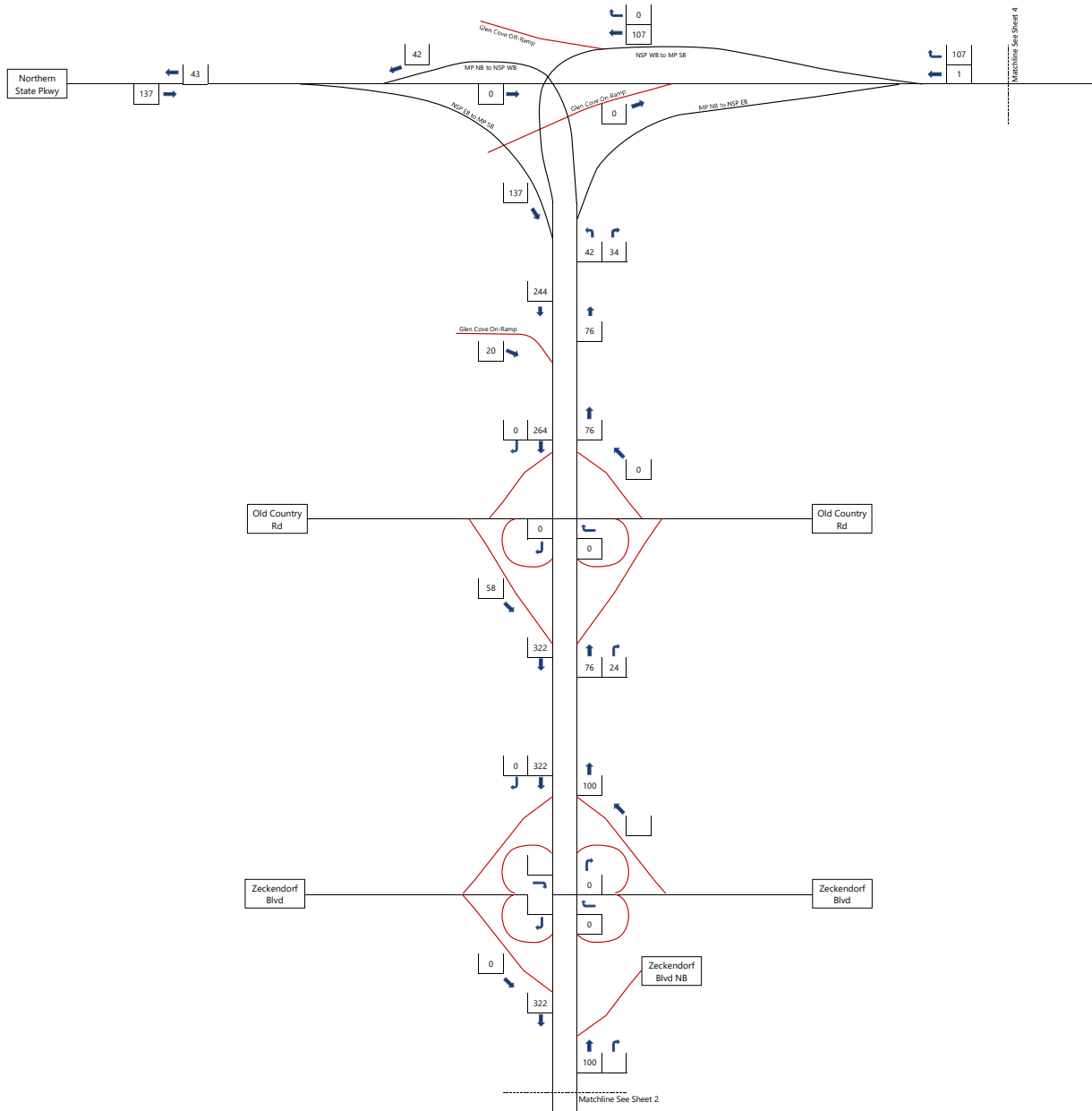

Figure V-D-3-3, Sheet 1
 2030 Trip Assignment - Restaurant/Retail/Public Attraction,
 Theater, Meetings and Conference
 Friday Evening Peak Hour
 26841.01 - Sands New York Integrated Resort
 Meadowbrook State Parkway



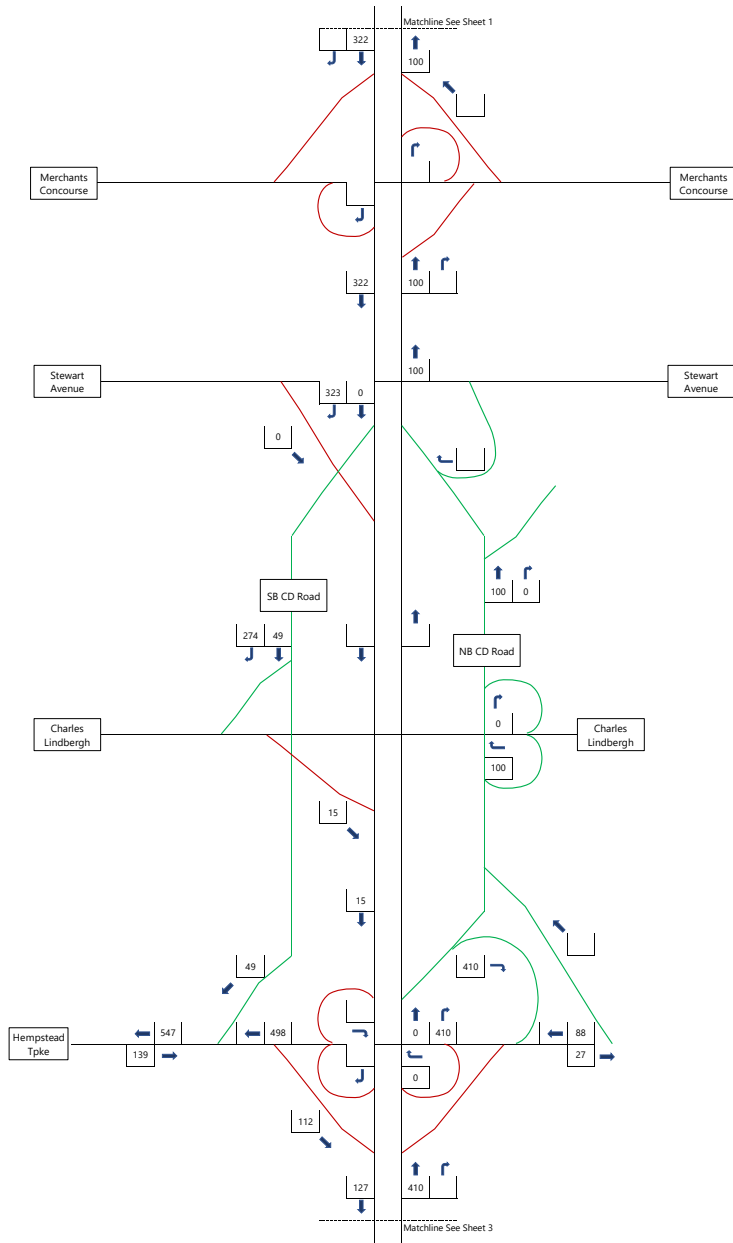

Figure V-D-3-3, Sheet 2
 2030 Trip Assignment - Restaurant/Retail/Public Attraction,
 Theater, Meetings and Conference
 Friday Evening Peak Hour
 26841.01 - Sands New York Integrated Resort
 Meadowbrook State Parkway



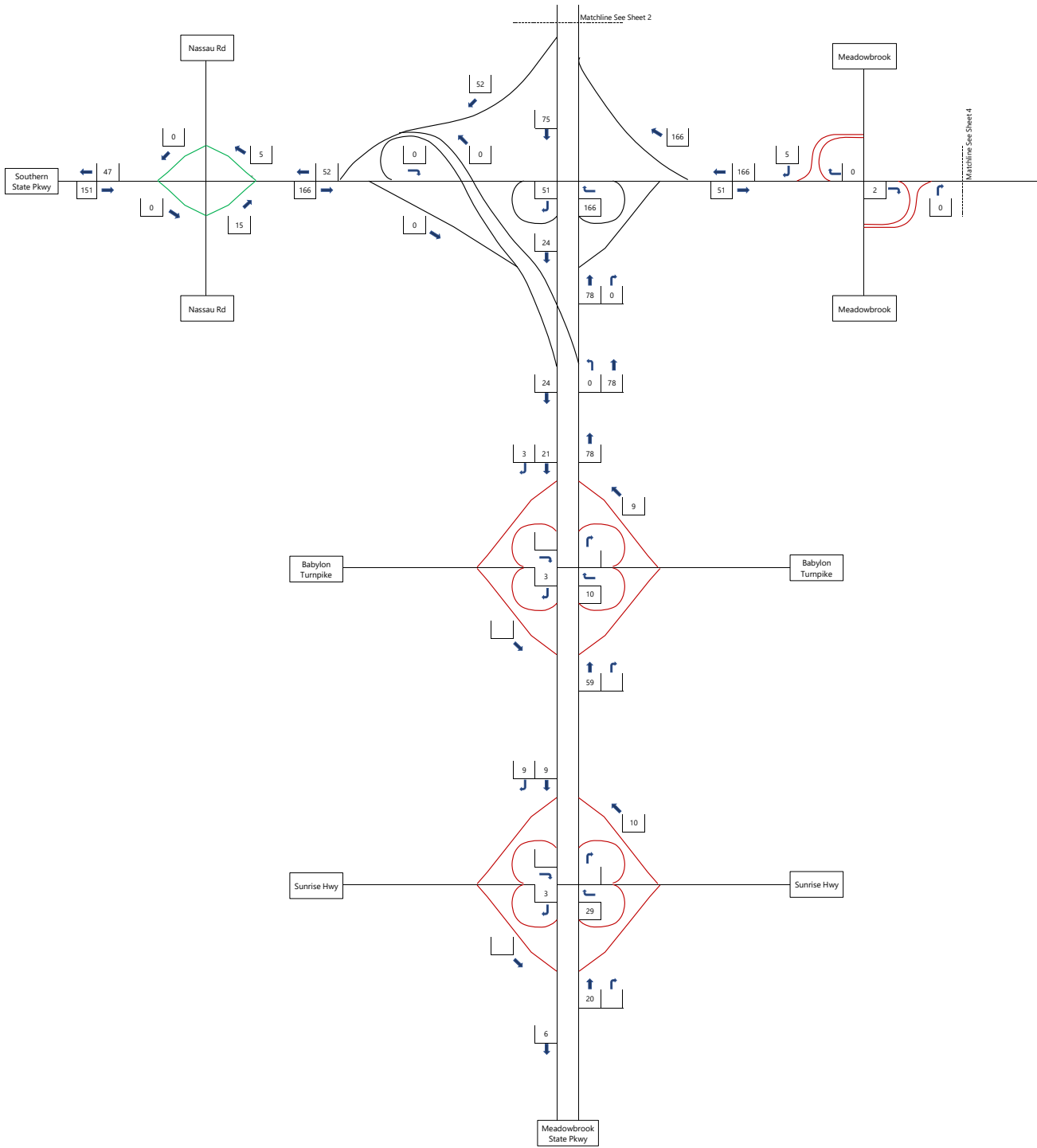

Figure V-D-3-3, Sheet 3
 2030 Trip Assignment - Restaurant/Retail/Public Attraction,
 Theater, Meetings and Conference
 Friday Evening Peak Hour
 26841.01 - Sands New York Integrated Resort
 Meadowbrook State Parkway



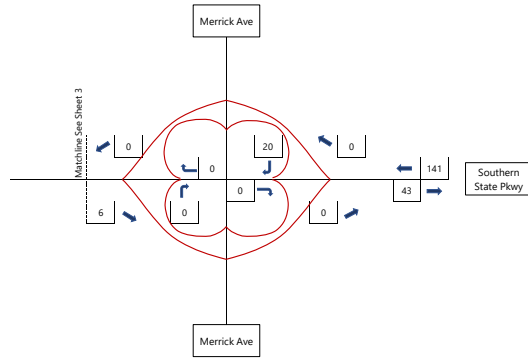
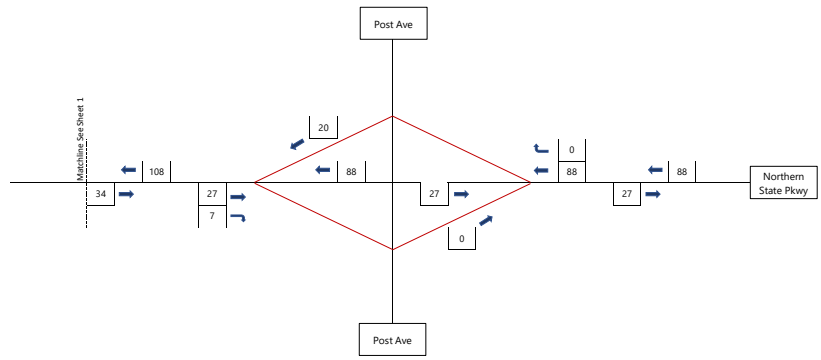

Figure V-D-3-3, Sheet 4
 2030 Trip Assignment - Restaurant/Retail/Public Attraction,
 Theater, Meetings and Conference
 Friday Evening Peak Hour
 26841.01 - Sands New York Integrated Resort
 Meadowbrook State Parkway



Not to Scale



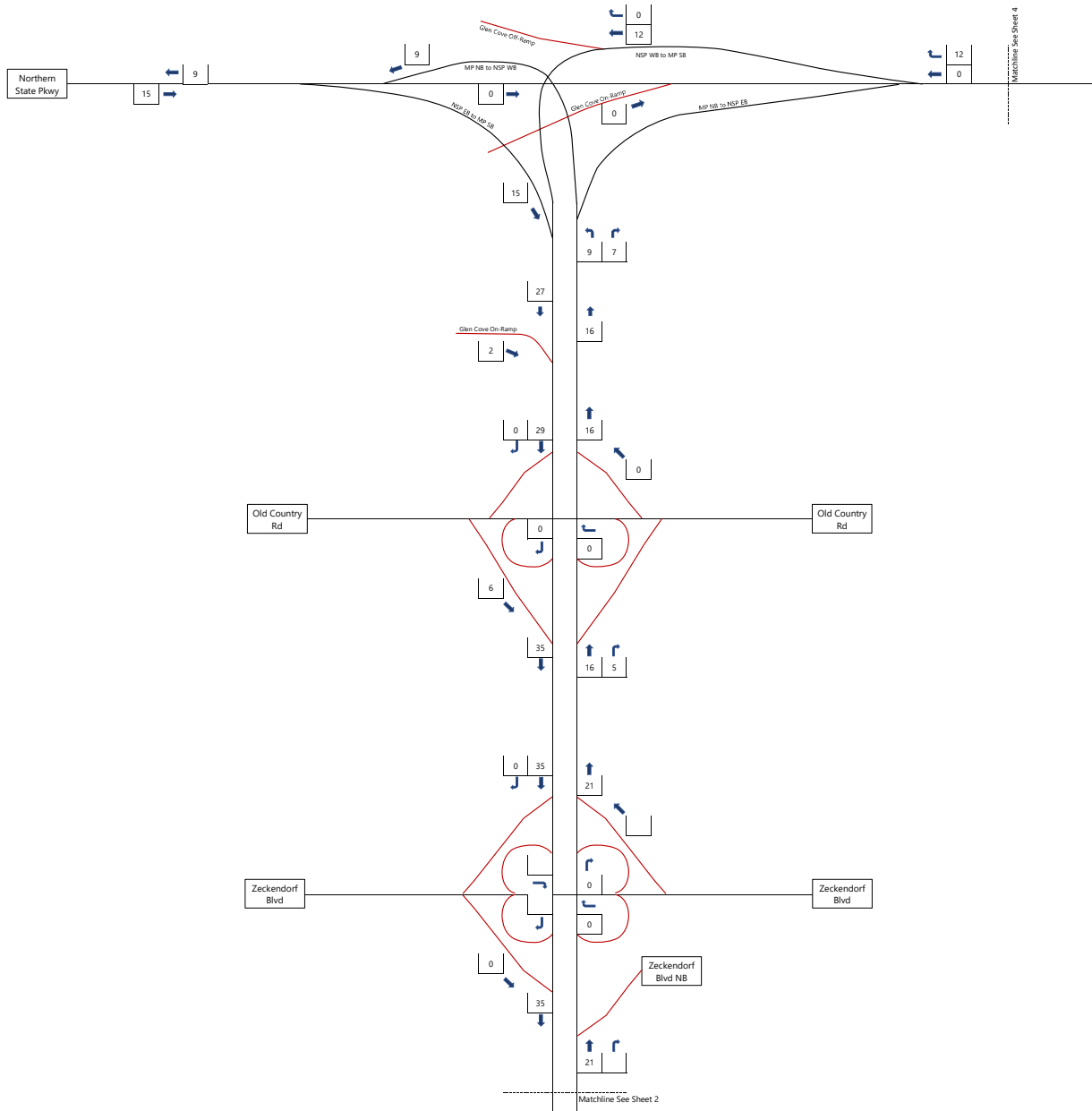

Figure V-D-3-4, Sheet 1
 2030 Trip Assignment - Ridehailing
 Friday Evening Peak Hour
 26841.01 - Sands New York Integrated Resort
 Meadowbrook State Parkway



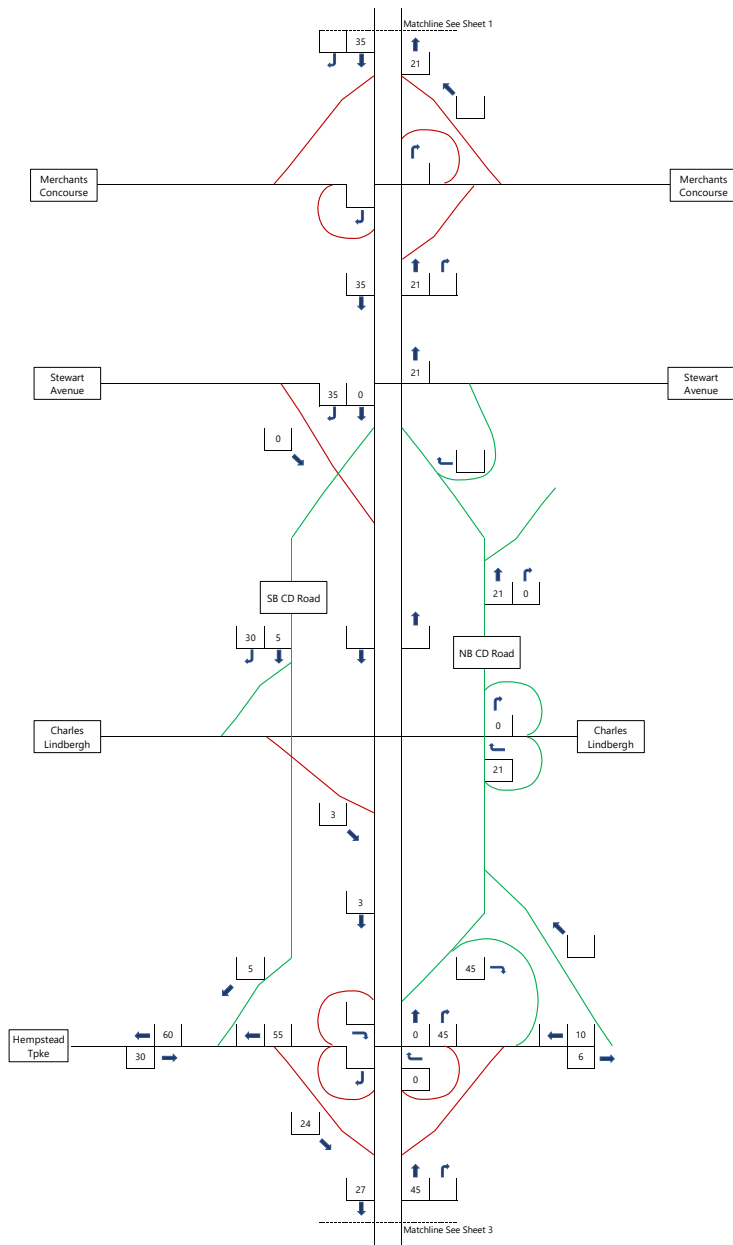

Figure V-D-3-4, Sheet 2
 2030 Trip Assignment - Ridehailing
 Friday Evening Peak Hour
 26841.01 - Sands New York Integrated Resort
 Meadowbrook State Parkway



Not to Scale



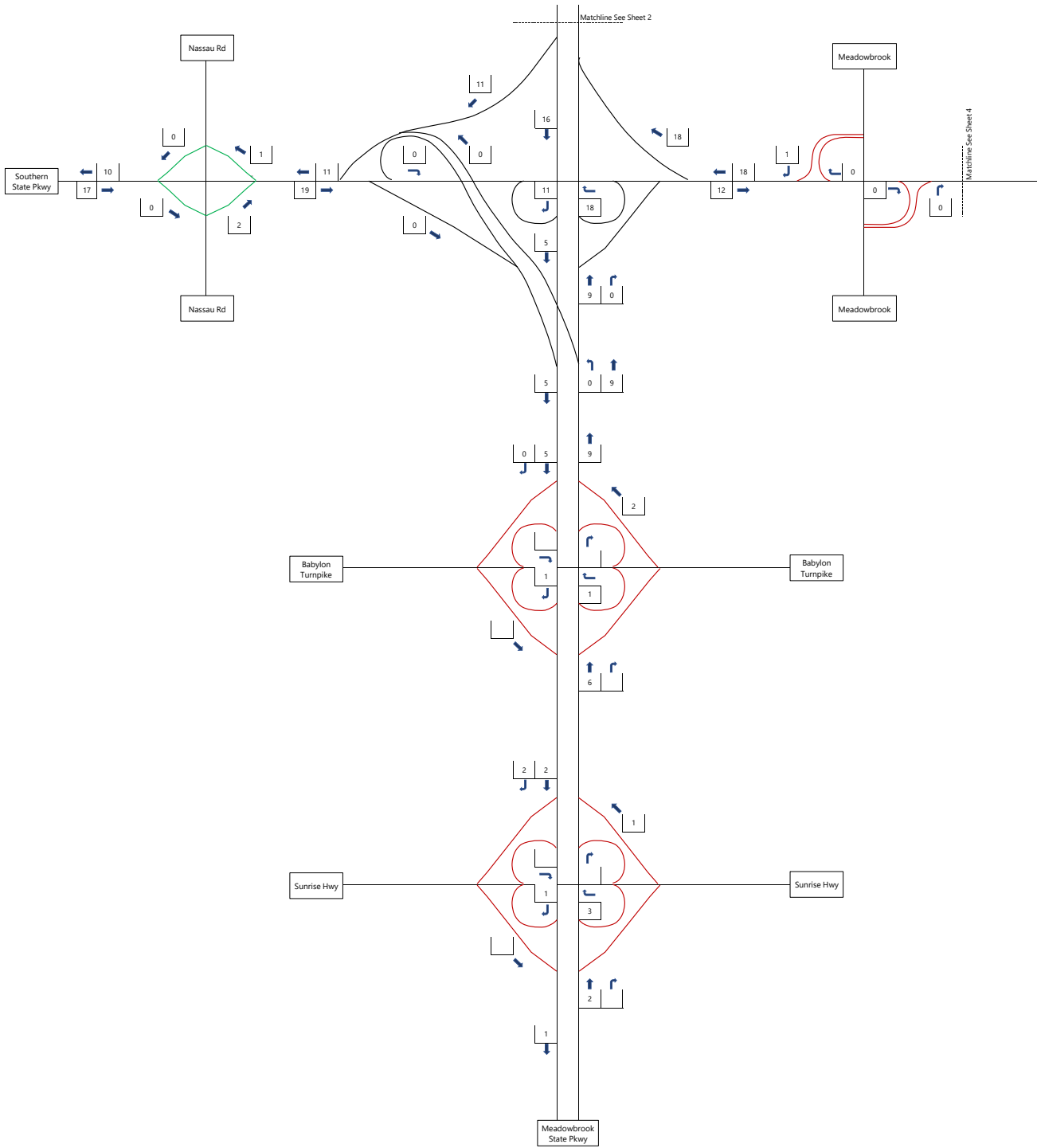

Figure V-D-3-4, Sheet 3
 2030 Trip Assignment - Ridehailing
 Friday Evening Peak Hour
 26841.01 - Sands New York Integrated Resort
 Meadowbrook State Parkway



Not to Scale



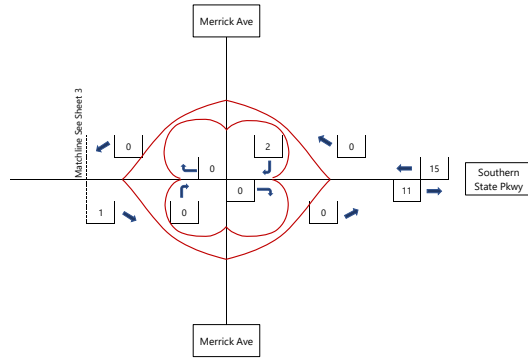
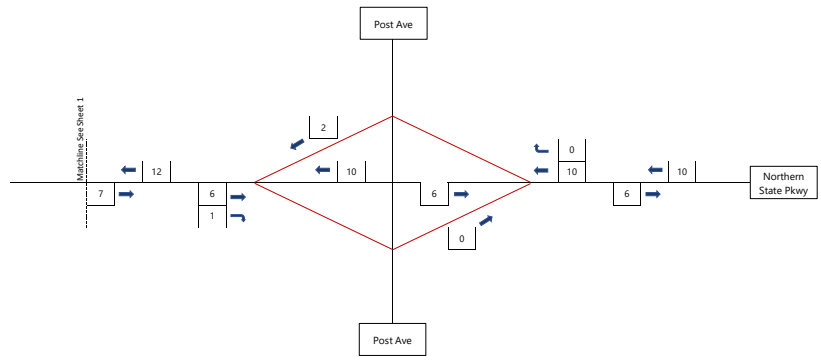

Figure V-D-3-4, Sheet 4
 2030 Trip Assignment - Ridehailing
 Friday Evening Peak Hour
 26841.01 - Sands New York Integrated Resort
 Meadowbrook State Parkway



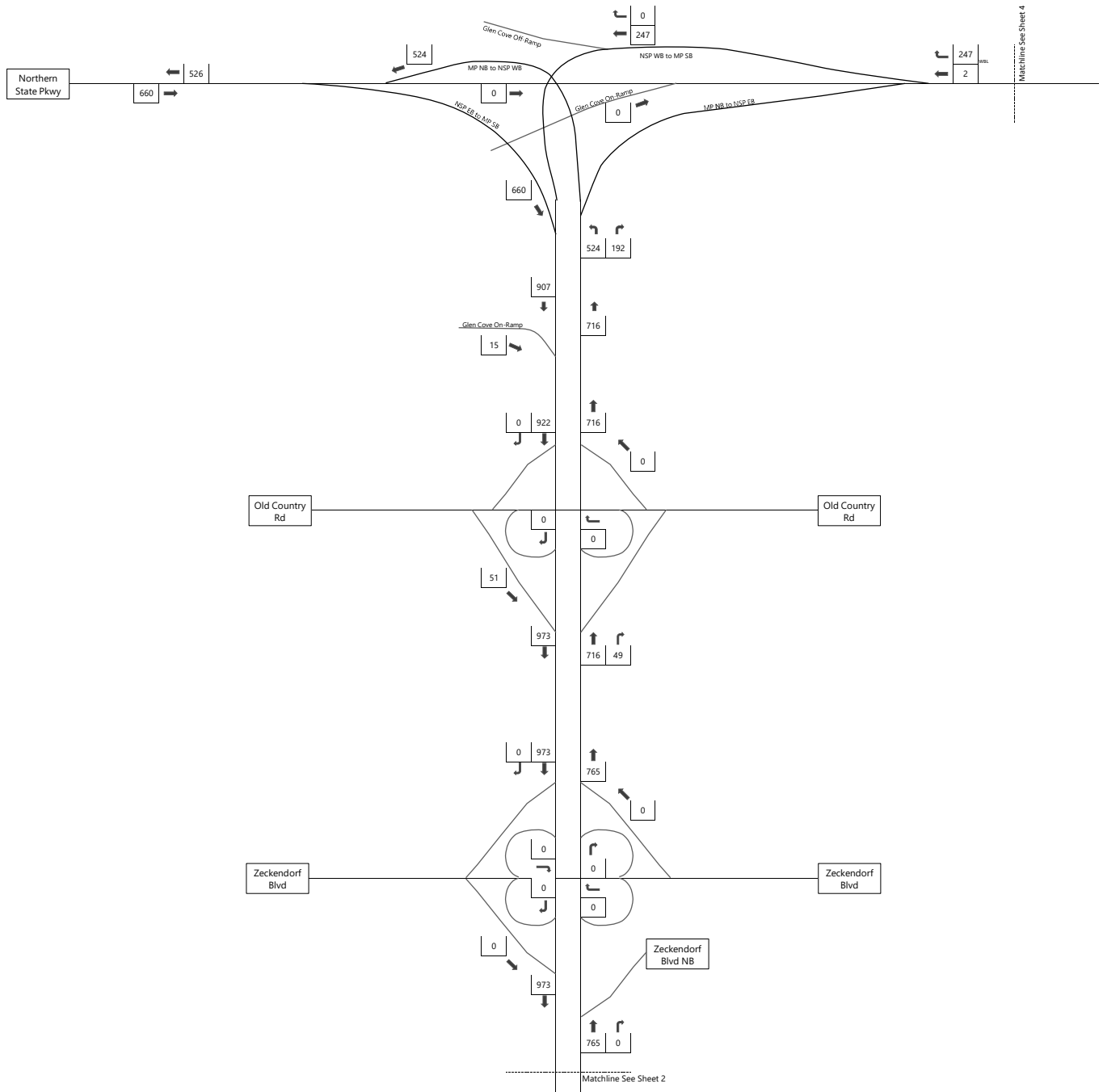

Figure V-D-4, Sheet 1
 2030 Combined Trip Assignment
 Saturday Midday Peak Hour
 26841.01 - Sands New York Integrated Resort
 Meadowbrook State Parkway



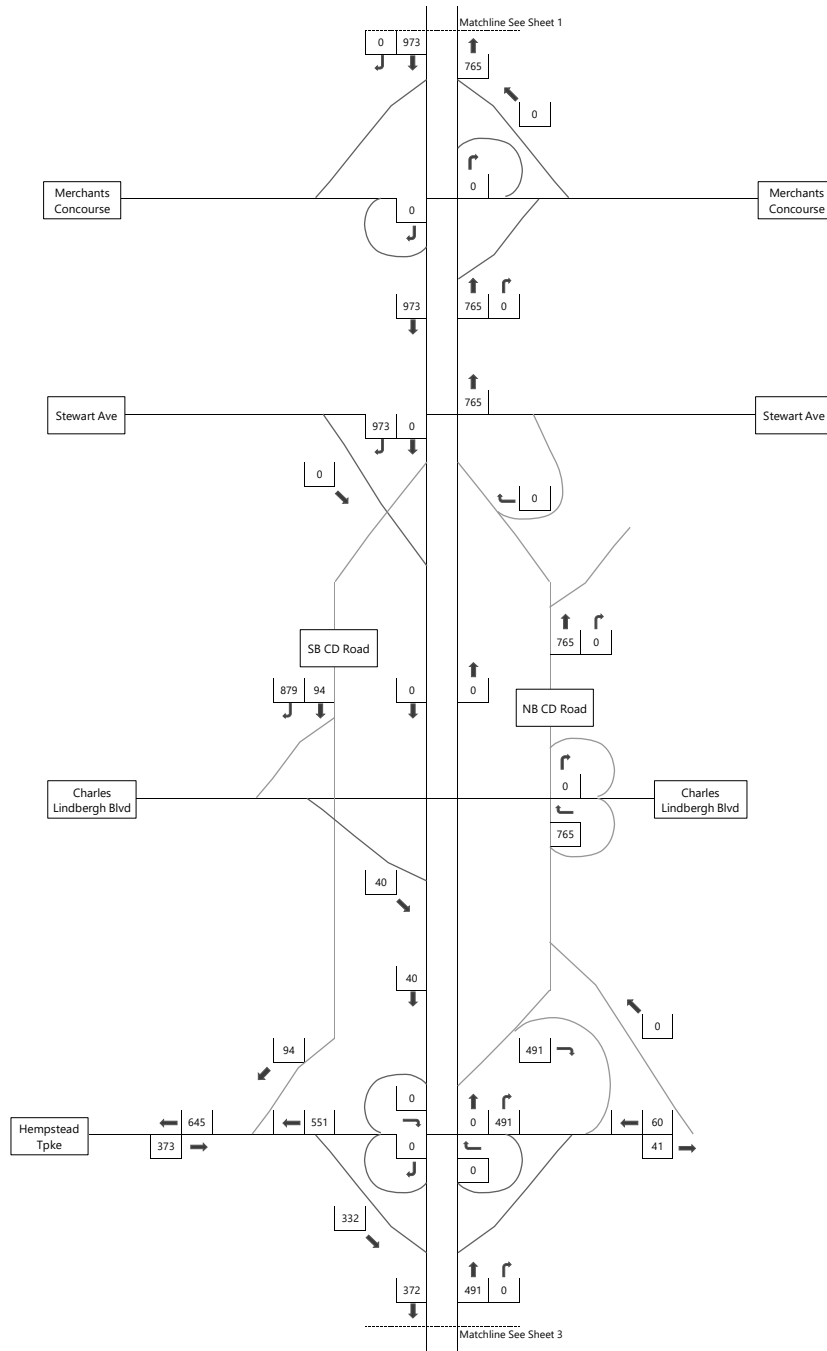

Figure V-D-4, Sheet 2
 2030 Combined Trip Assignment
 Saturday Midday Peak Hour
 26841.01 - Sands New York Integrated Resort
 Meadowbrook State Parkway



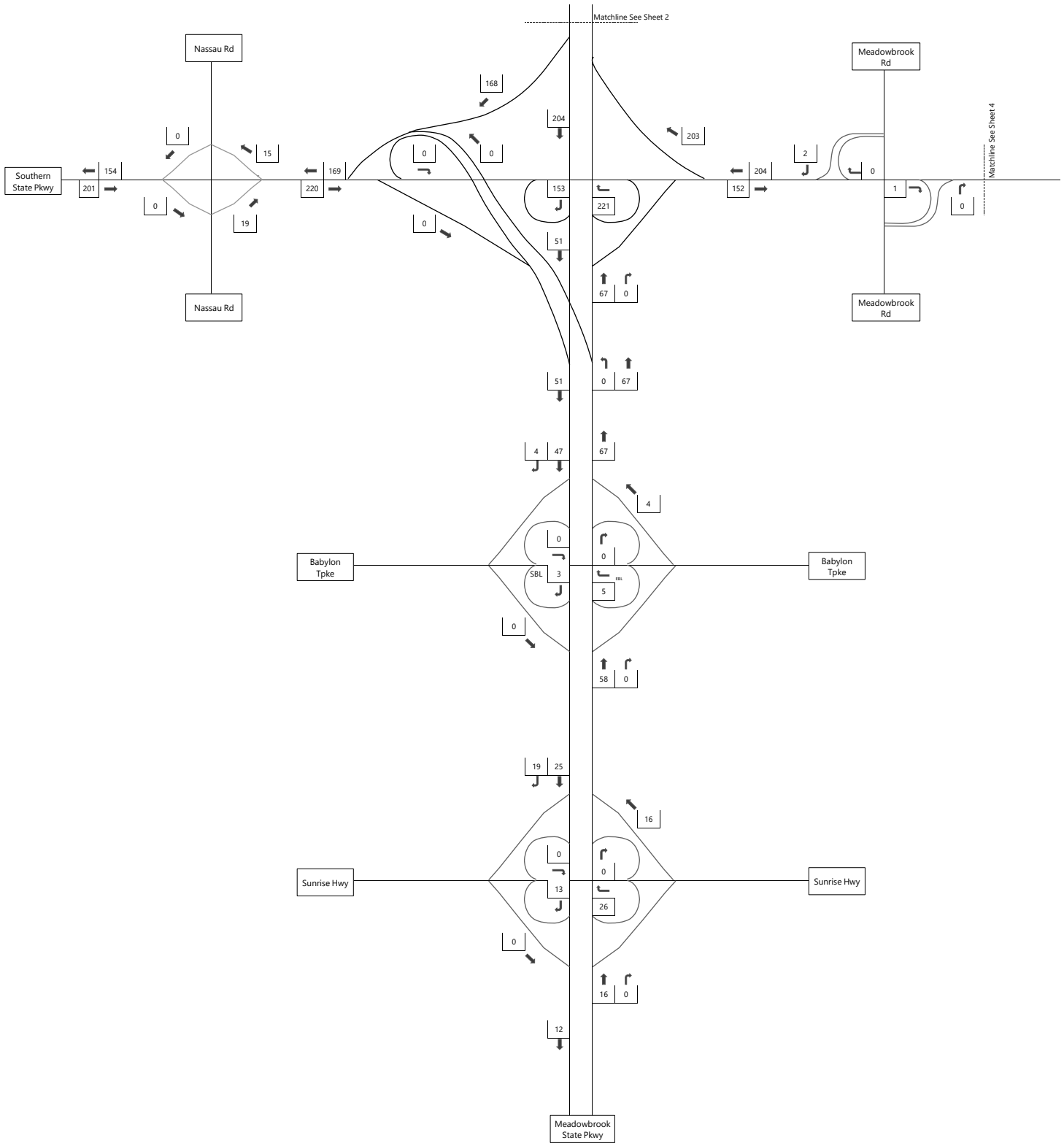

Figure V-D-4, Sheet 3
 2030 Combined Trip Assignment
 Saturday Midday Peak Hour
 26841.01 - Sands New York Integrated Resort
 Meadowbrook State Parkway



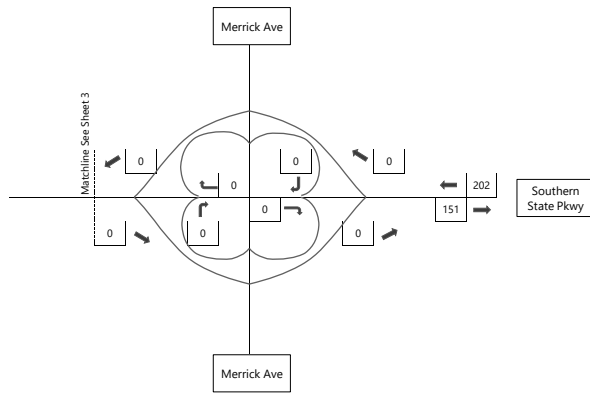
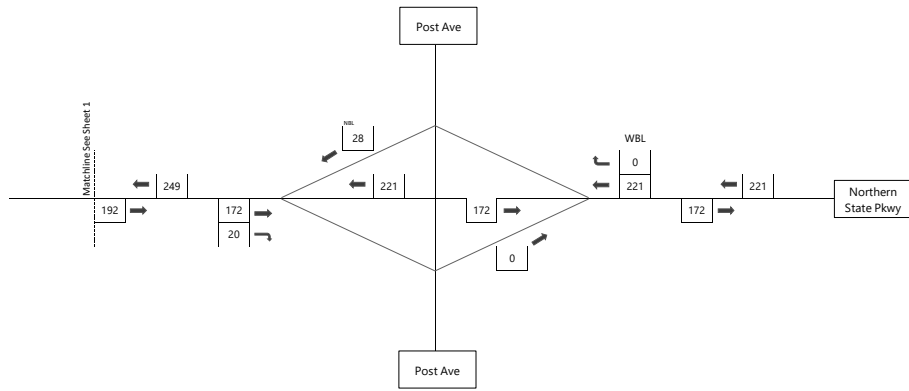

Figure V-D-4, Sheet 4
 2030 Combined Trip Assignment
 Saturday Midday Peak Hour
 26841.01 - Sands New York Integrated Resort
 Meadowbrook State Parkway



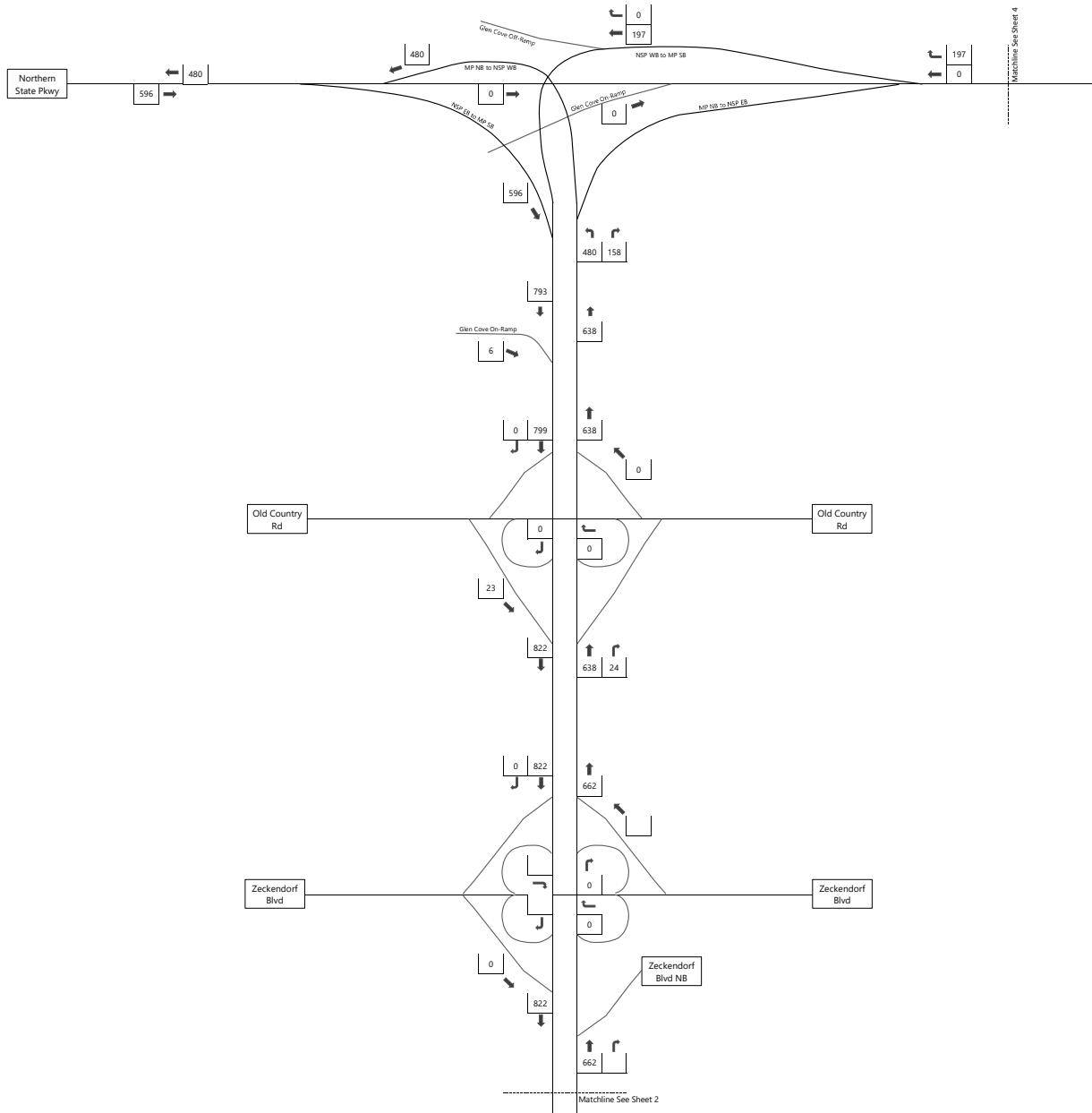

Figure V-D-4-1, Sheet 1
 2030 Trip Assignment - Casino/Hotel
 Saturday Midday Peak Hour
 26841.01 - Sands New York Integrated Resort
 Meadowbrook State Parkway



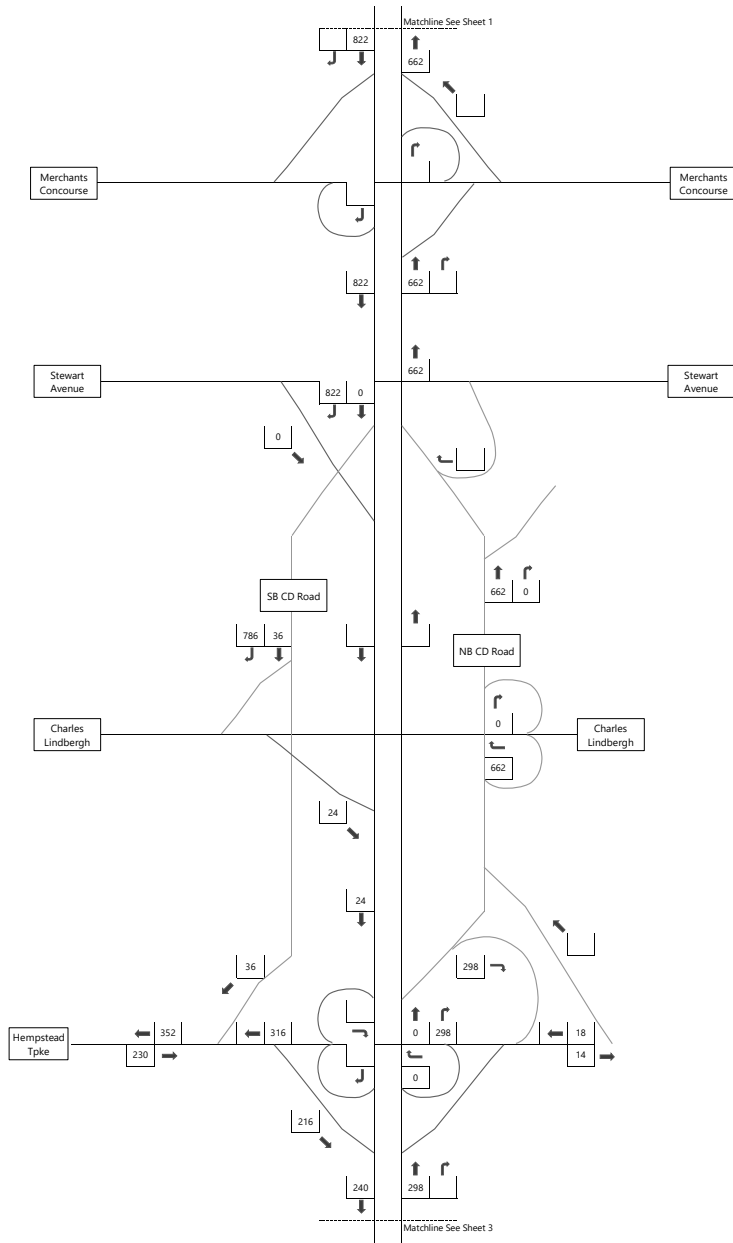

Figure V-D-4-1, Sheet 2
 2030 Trip Assignment - Casino/Hotel
 Saturday Midday Peak Hour
 26841.01 - Sands New York Integrated Resort
 Meadowbrook State Parkway



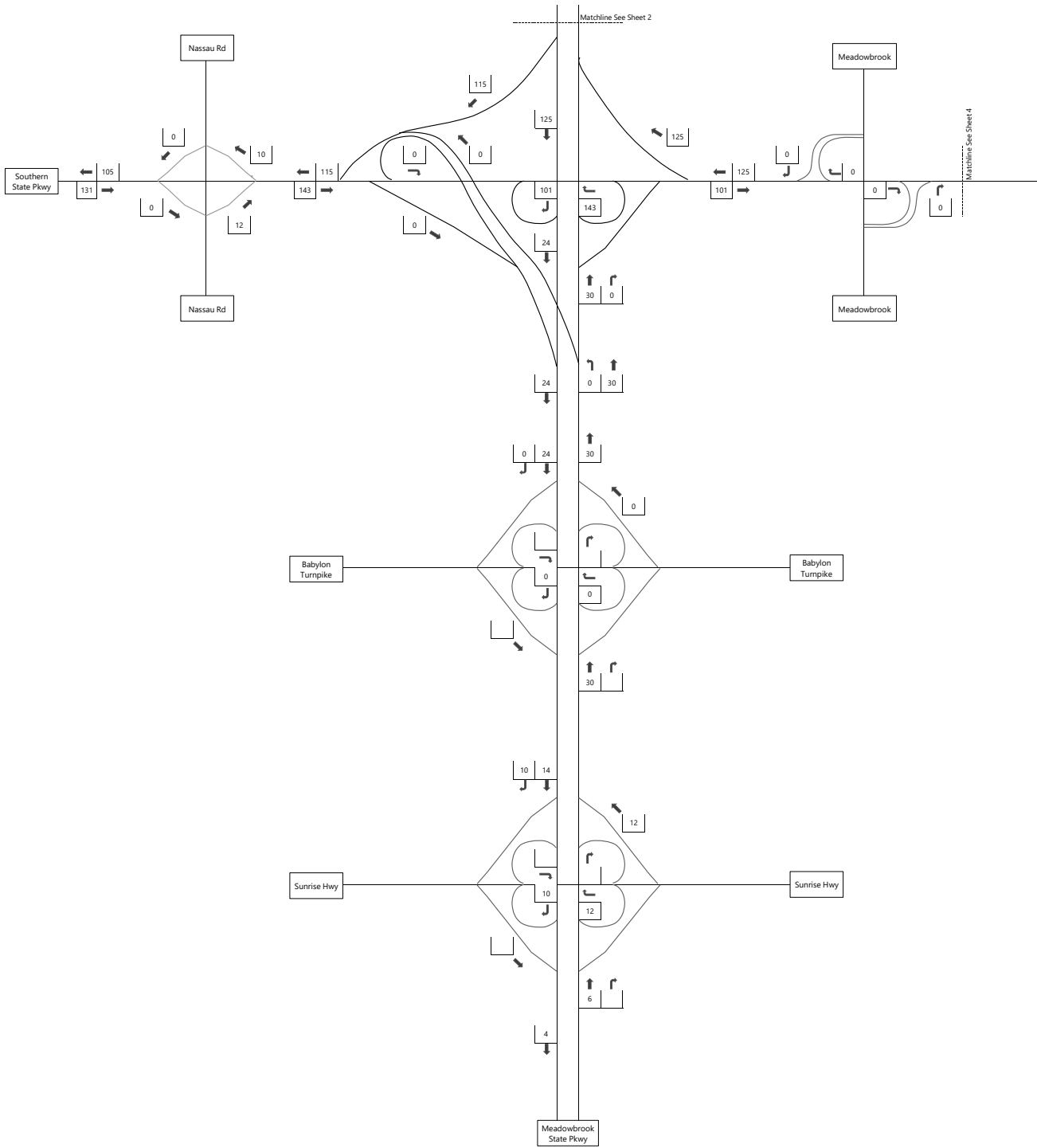

Figure V-D-4-1, Sheet 3
 2030 Trip Assignment - Casino/Hotel
 Saturday Midday Peak Hour
 26841.01 - Sands New York Integrated Resort
 Meadowbrook State Parkway



Not to Scale



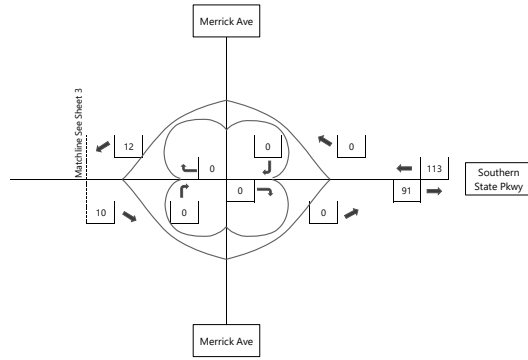
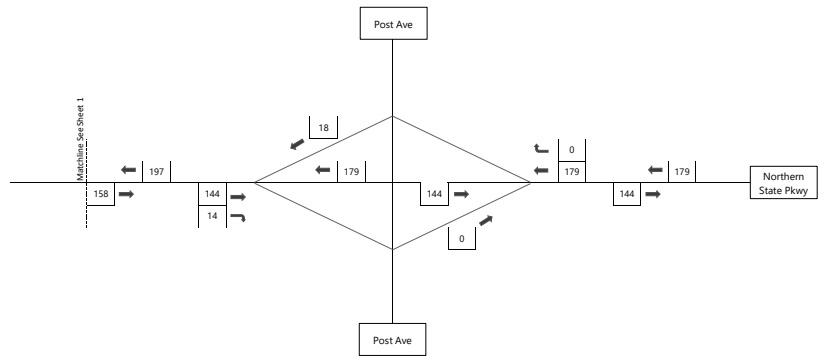

Figure V-D-4-1, Sheet 4
 2030 Trip Assignment - Casino/Hotel
 Saturday Midday Peak Hour
 26841.01 - Sands New York Integrated Resort
 Meadowbrook State Parkway



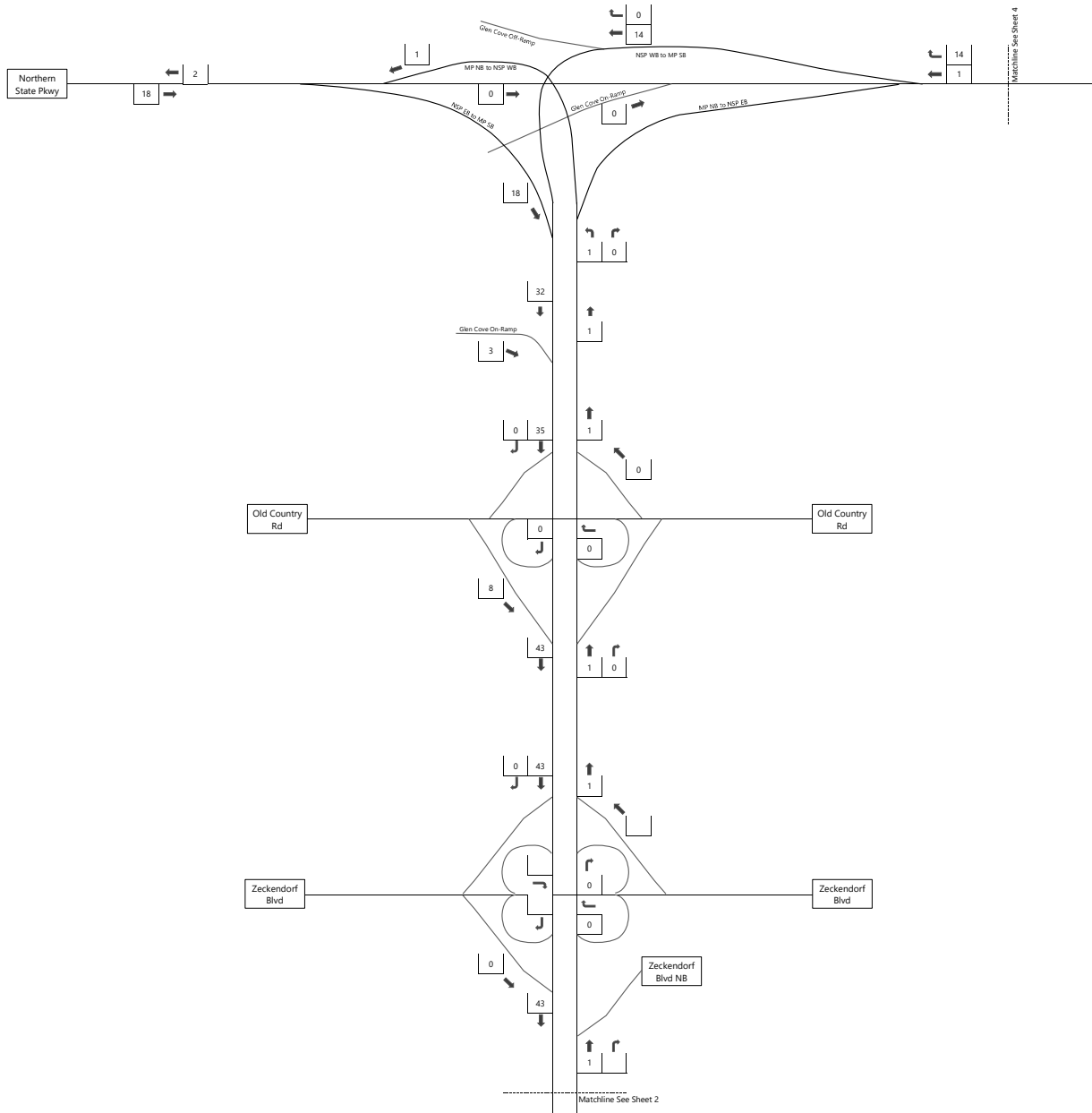

Figure V-D-4-2, Sheet 1
 2030 Trip Assignment - Employee
 Saturday Midday Peak Hour
 26841.01 - Sands New York Integrated Resort
 Meadowbrook State Parkway



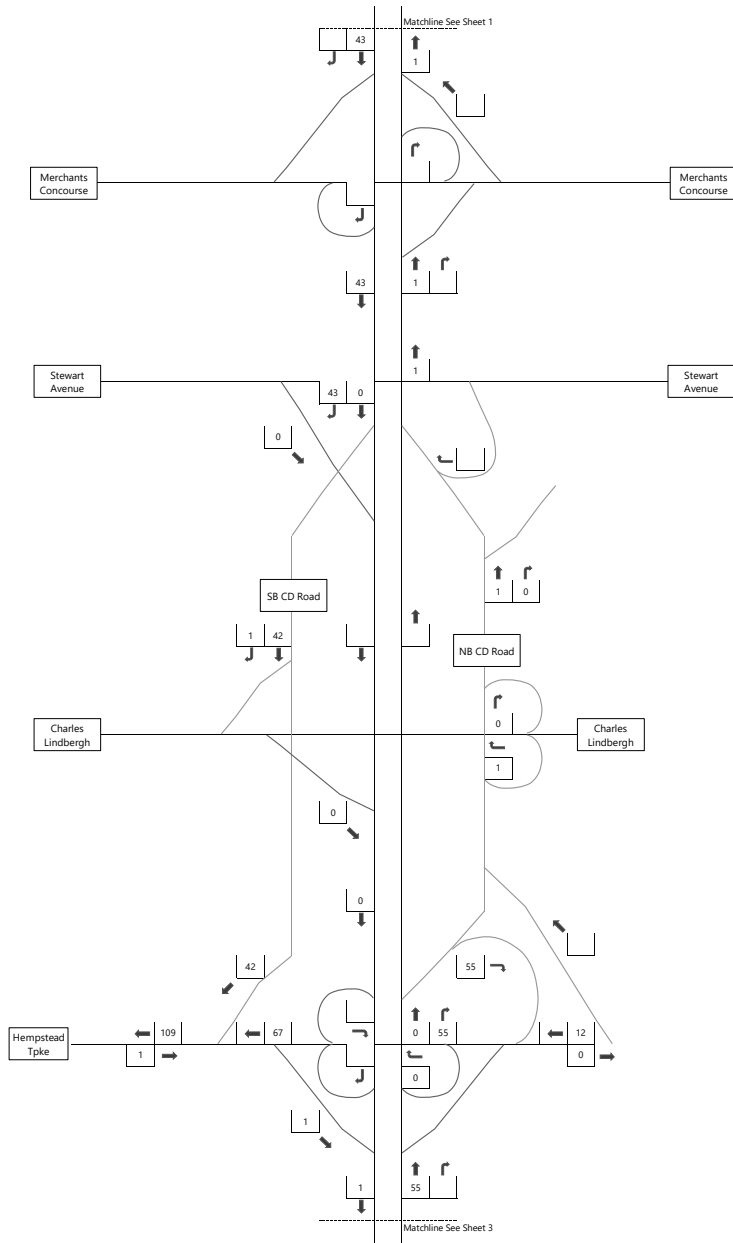

Figure V-D-4-2, Sheet 2
 2030 Trip Assignment - Employee
 Saturday Midday Peak Hour
 26841.01 - Sands New York Integrated Resort
 Meadowbrook State Parkway



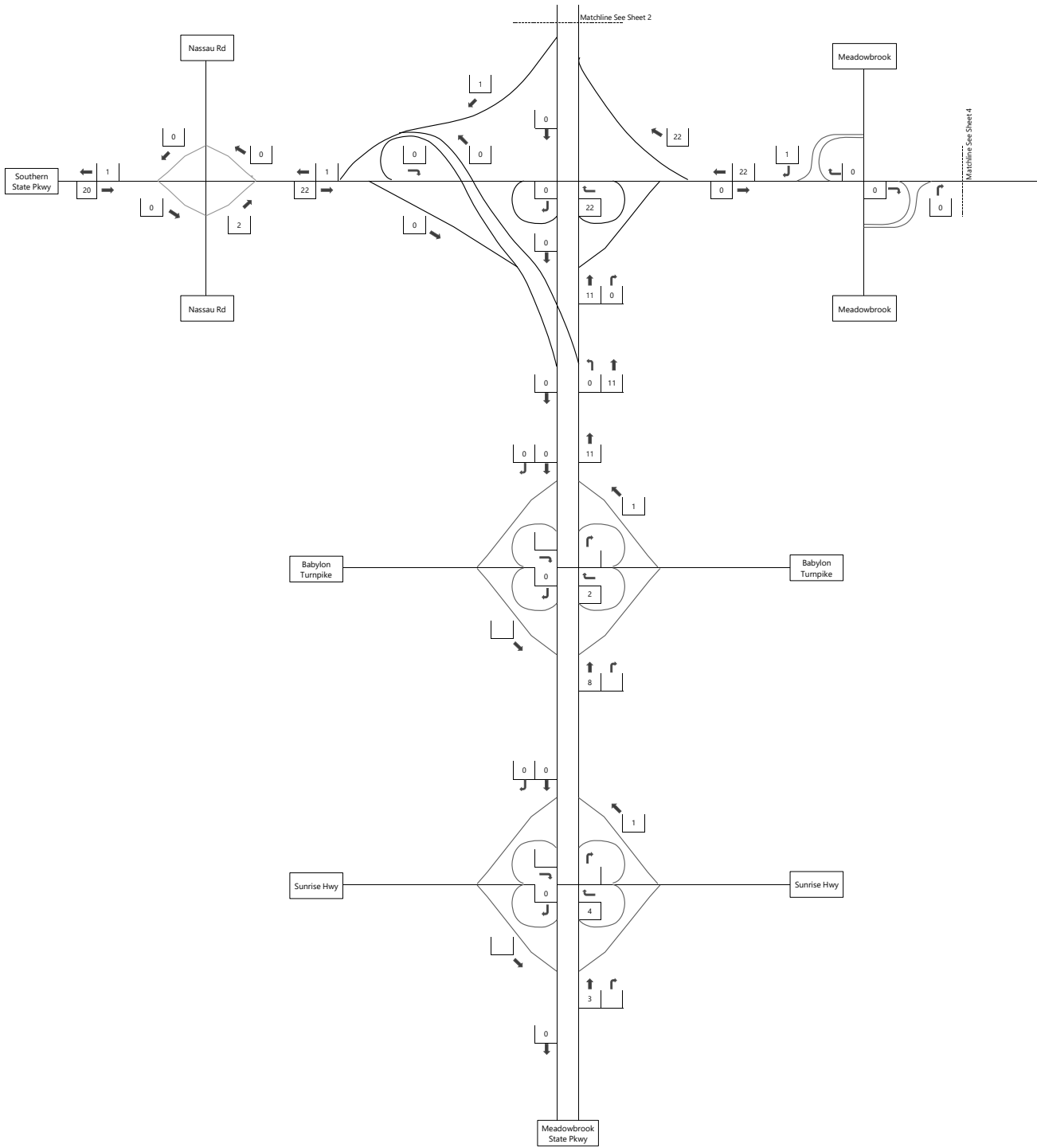

Figure V-D-4-2, Sheet 3
 2030 Trip Assignment - Employee
 Saturday Midday Peak Hour
 26841.01 - Sands New York Integrated Resort
 Meadowbrook State Parkway



Not to Scale



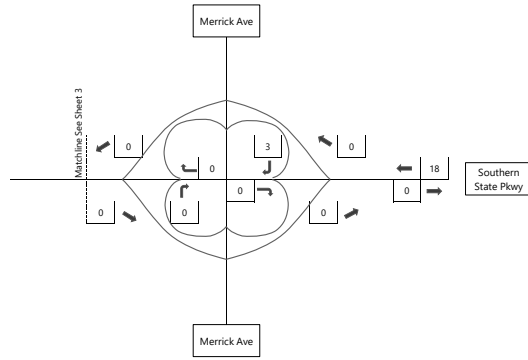
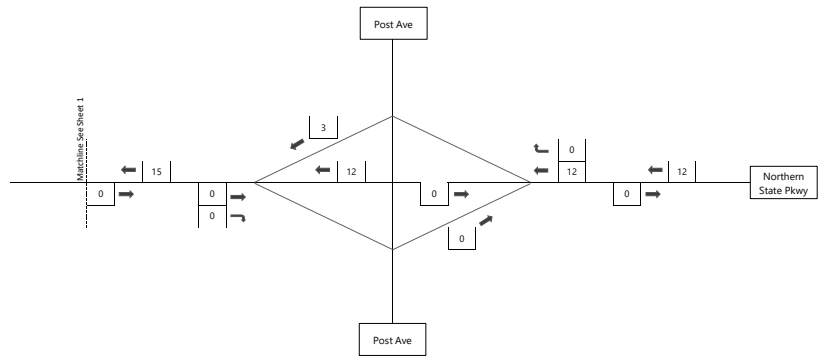

Figure V-D-4-2, Sheet 4
 2030 Trip Assignment - Employee
 Saturday Midday Peak Hour
 26841.01 - Sands New York Integrated Resort
 Meadowbrook State Parkway



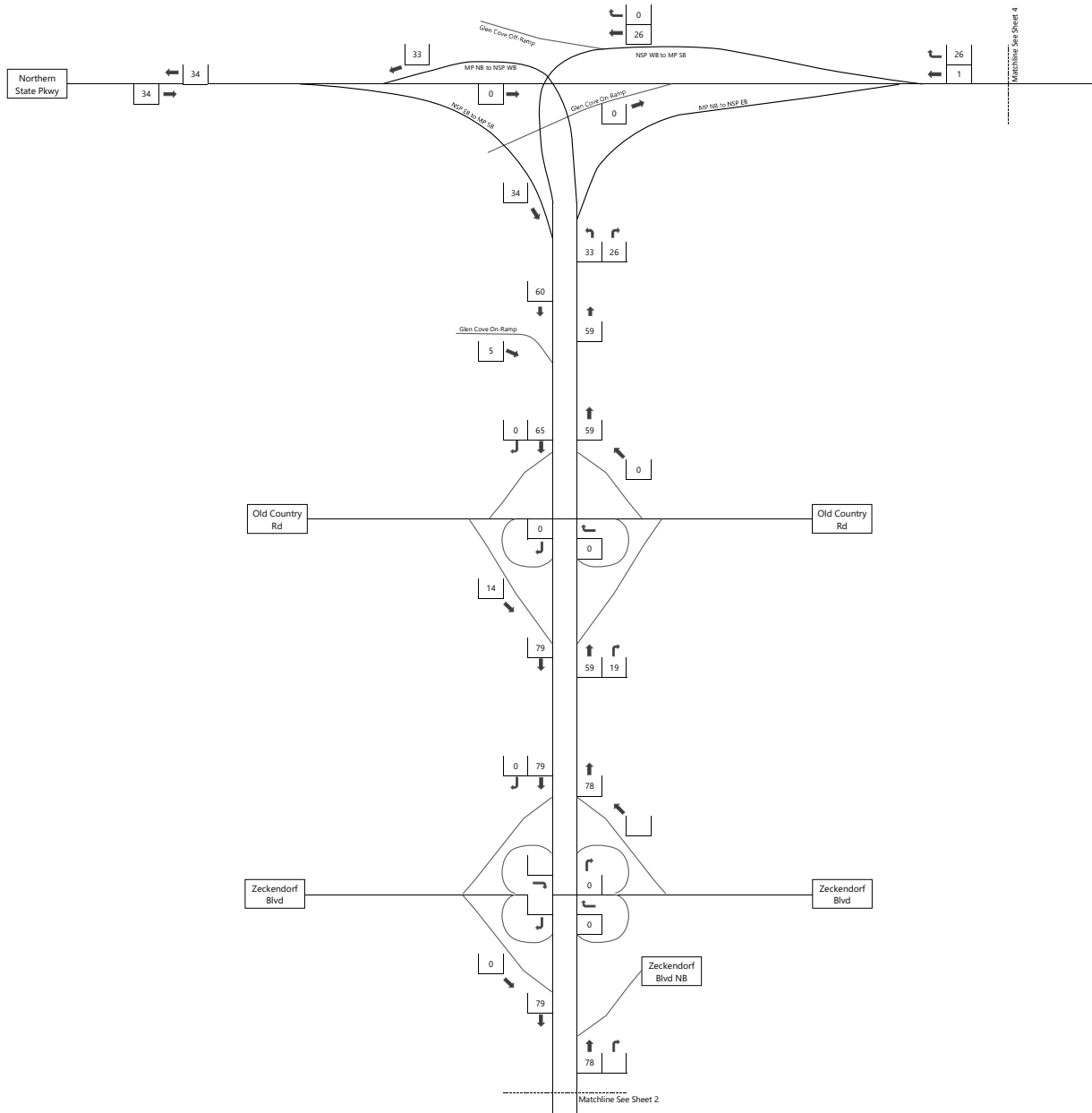

Figure V-D-4-3, Sheet 1
 2030 Trip Assignment - Restaurant/Retail/Public Attraction,
 Theater, Meetings and Conference
 Saturday Midday Peak Hour
 26841.01 - Sands New York Integrated Resort
 Meadowbrook State Parkway



Not to Scale



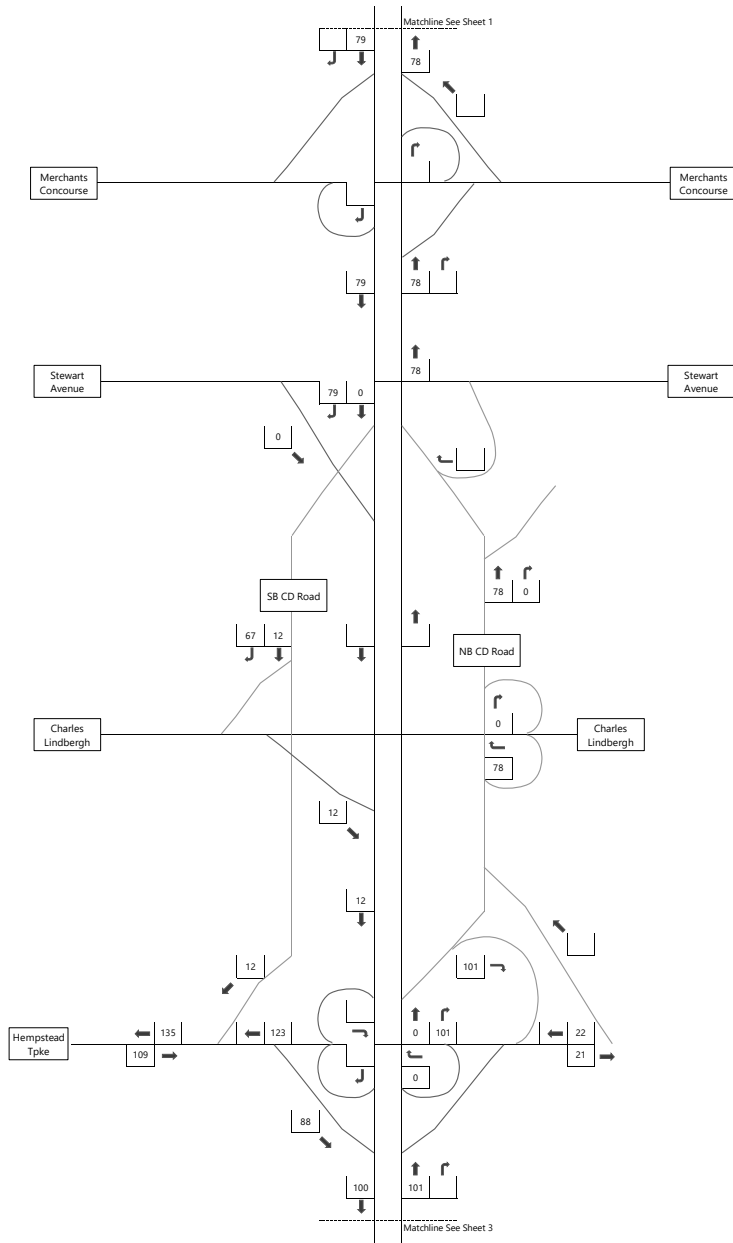

Figure V-D-4-3, Sheet 2
 2030 Trip Assignment - Restaurant/Retail/Public Attraction,
 Theater, Meetings and Conference
 Saturday Midday Peak Hour
 26841.01 - Sands New York Integrated Resort
 Meadowbrook State Parkway



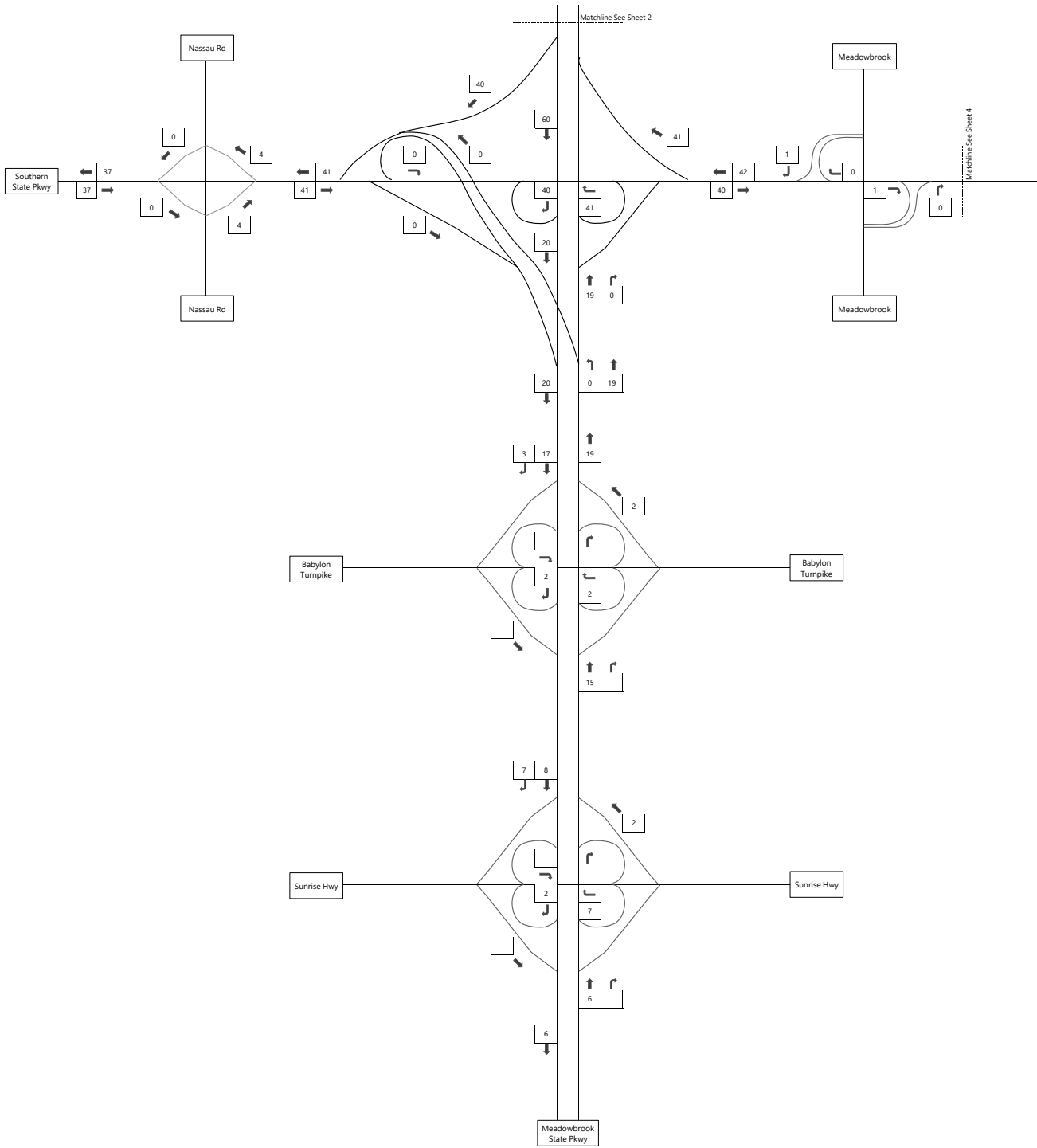

Figure V-D-4-3, Sheet 3
 2030 Trip Assignment - Restaurant/Retail/Public Attraction,
 Theater, Meetings and Conference
 Saturday Midday Peak Hour
 26841.01 - Sands New York Integrated Resort
 Meadowbrook State Parkway



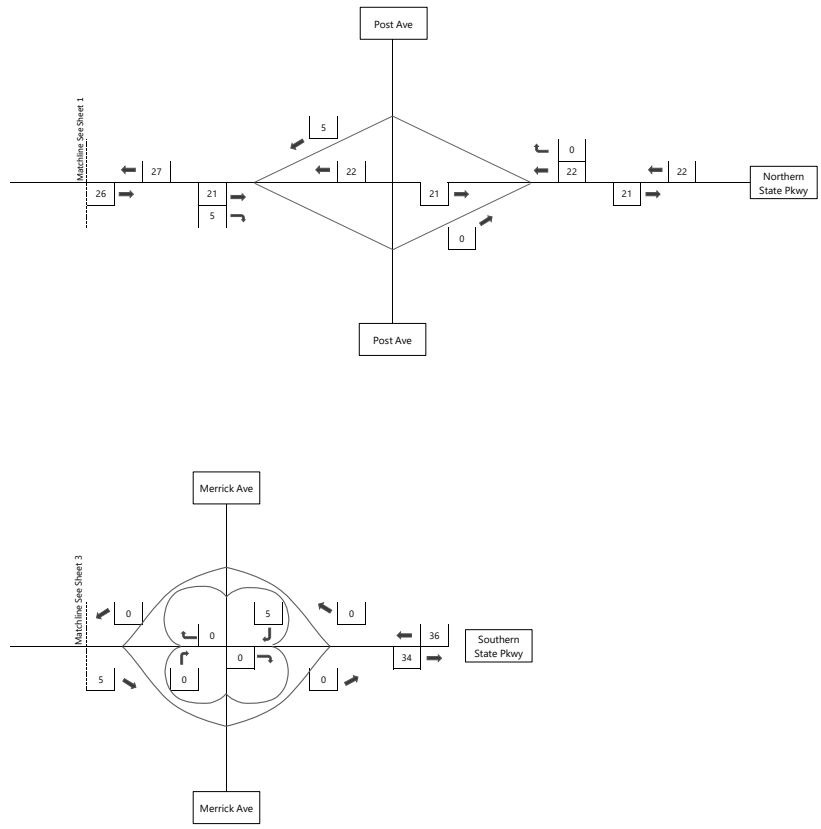

Figure V-D-4-3, Sheet 4
 2030 Trip Assignment - Restaurant/Retail/Public Attraction,
 Theater, Meetings and Conference
 Saturday Midday Peak Hour
 26841.01 - Sands New York Integrated Resort
 Meadowbrook State Parkway



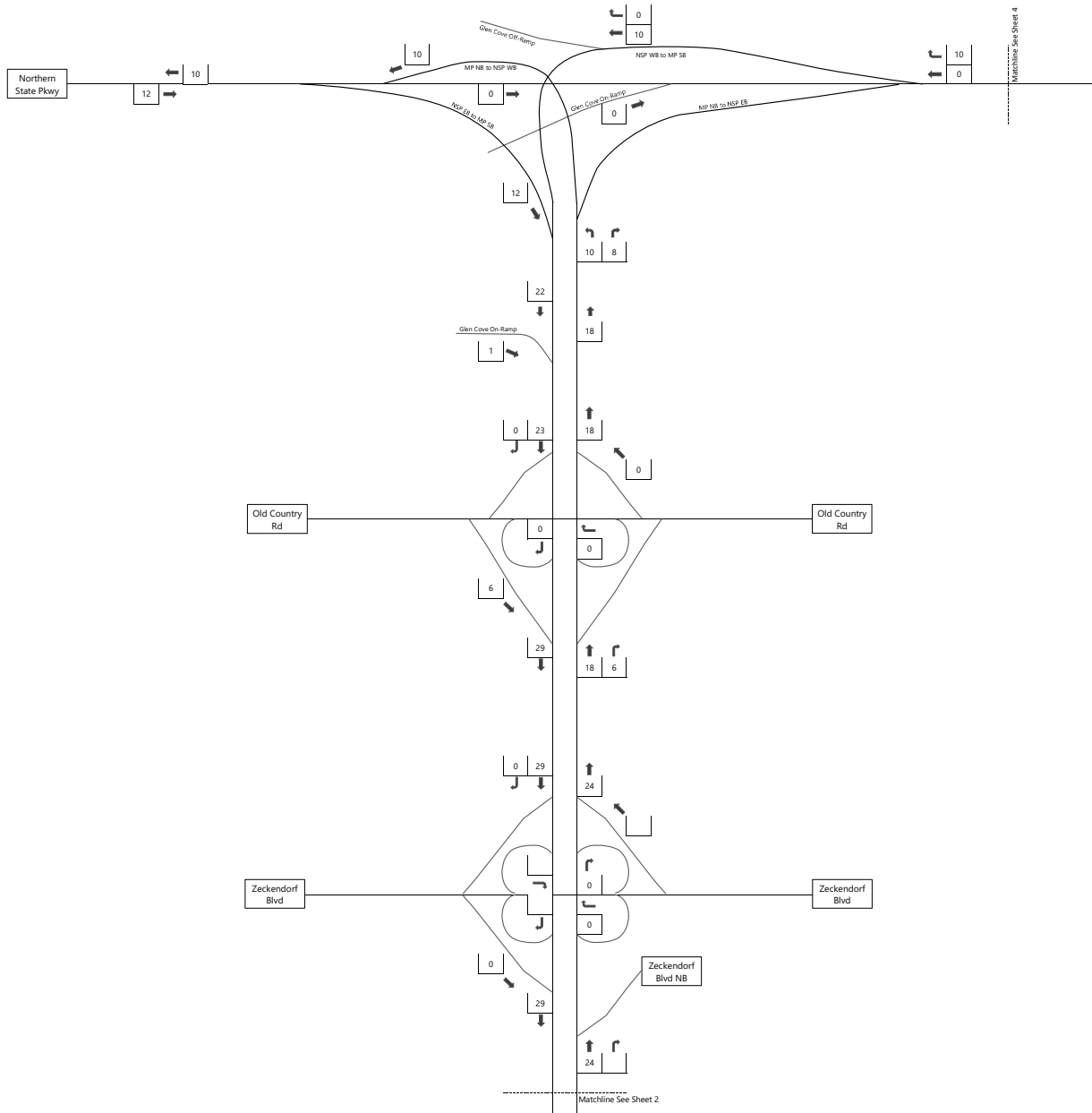

Figure V-D-4-4, Sheet 1
 2030 Trip Assignment - Ridehailing
 Saturday Midday Peak Hour
 26841.01 - Sands New York Integrated Resort
 Meadowbrook State Parkway



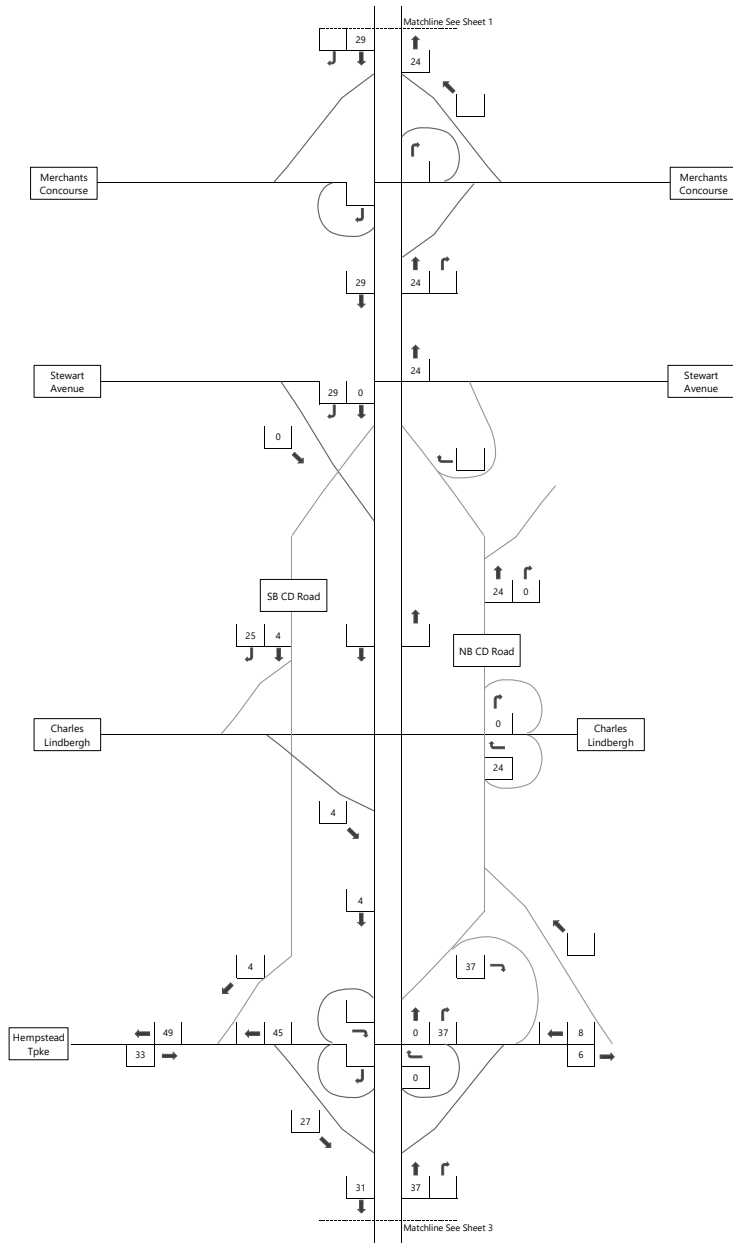

Figure V-D-4-4, Sheet 2
 2030 Trip Assignment - Ridehailing
 Saturday Midday Peak Hour
 26841.01 - Sands New York Integrated Resort
 Meadowbrook State Parkway



Not to Scale



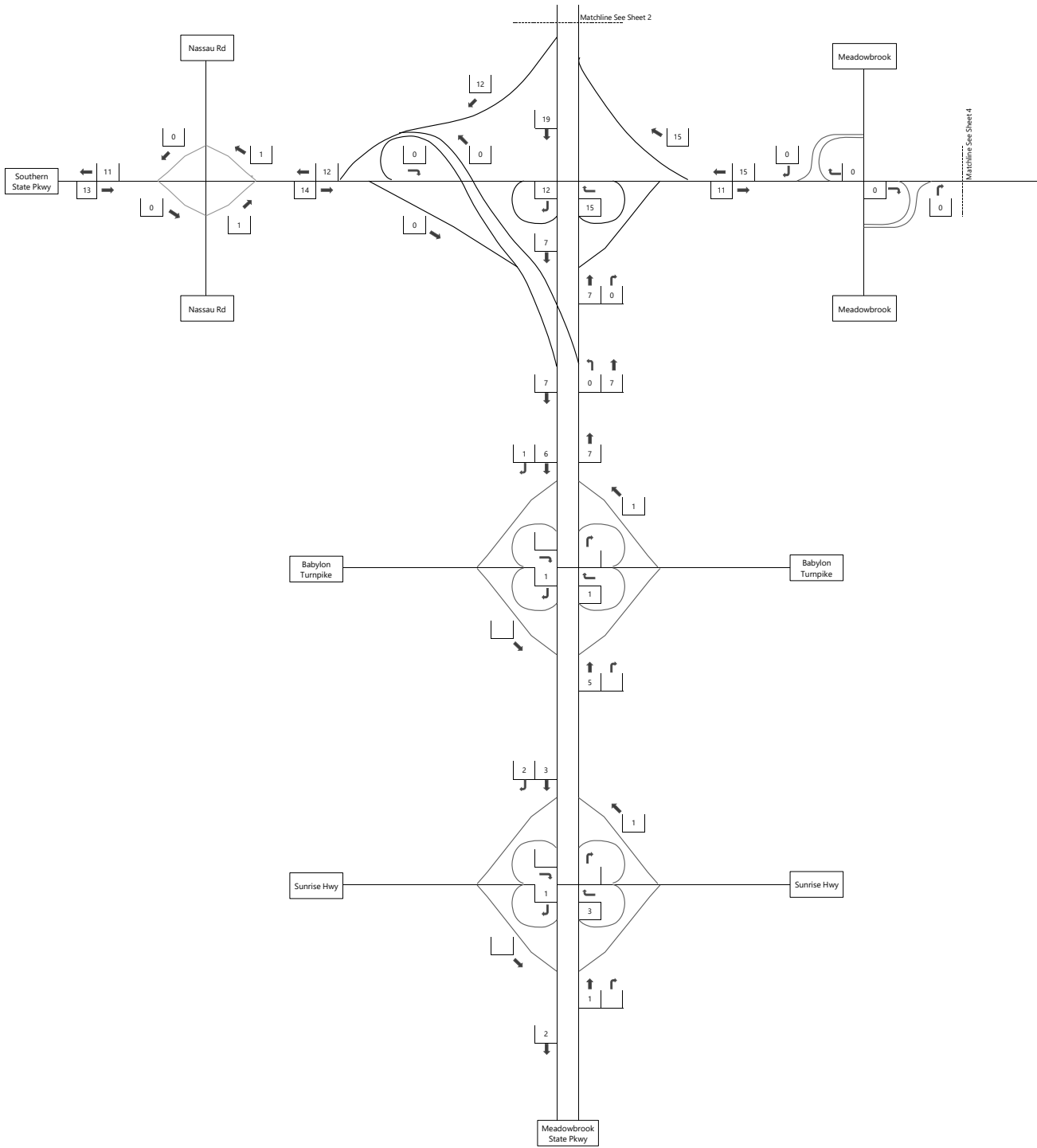

Figure V-D-4-4, Sheet 3
 2030 Trip Assignment - Ridehailing
 Saturday Midday Peak Hour
 26841.01 - Sands New York Integrated Resort
 Meadowbrook State Parkway



Not to Scale



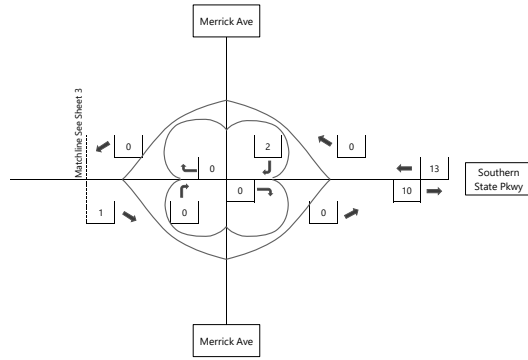
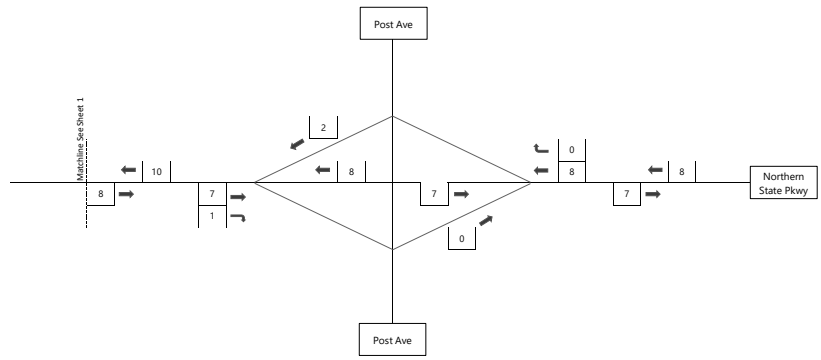

Figure V-D-4-4, Sheet 4
 2030 Trip Assignment - Ridehailing
 Saturday Midday Peak Hour
 26841.01 - Sands New York Integrated Resort
 Meadowbrook State Parkway



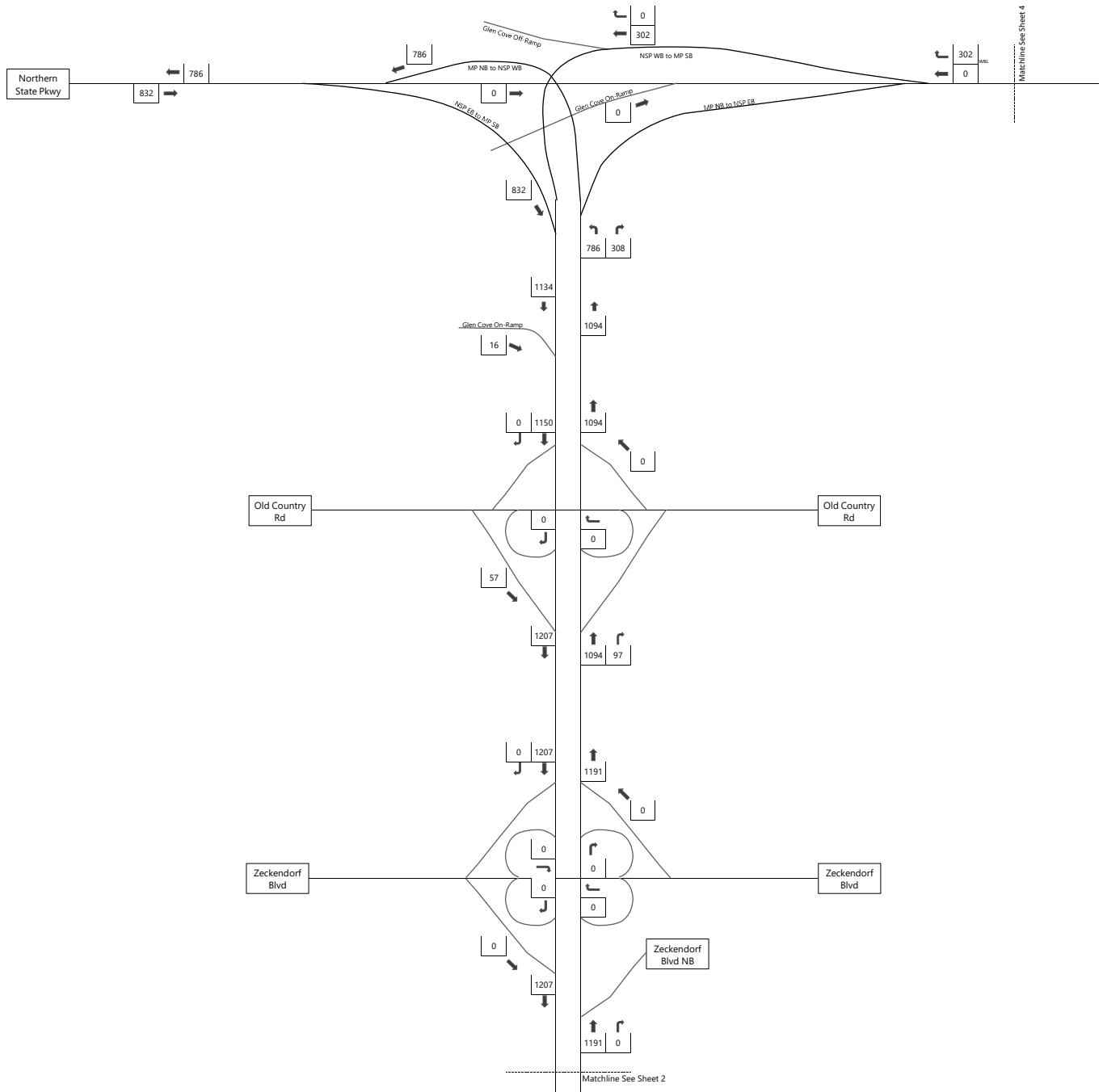

Figure V-D-5, Sheet 1
 2030 Combined Trip Assignment
 Saturday Evening Peak Hour
 26841.01 - Sands New York Integrated Resort
 Meadowbrook State Parkway



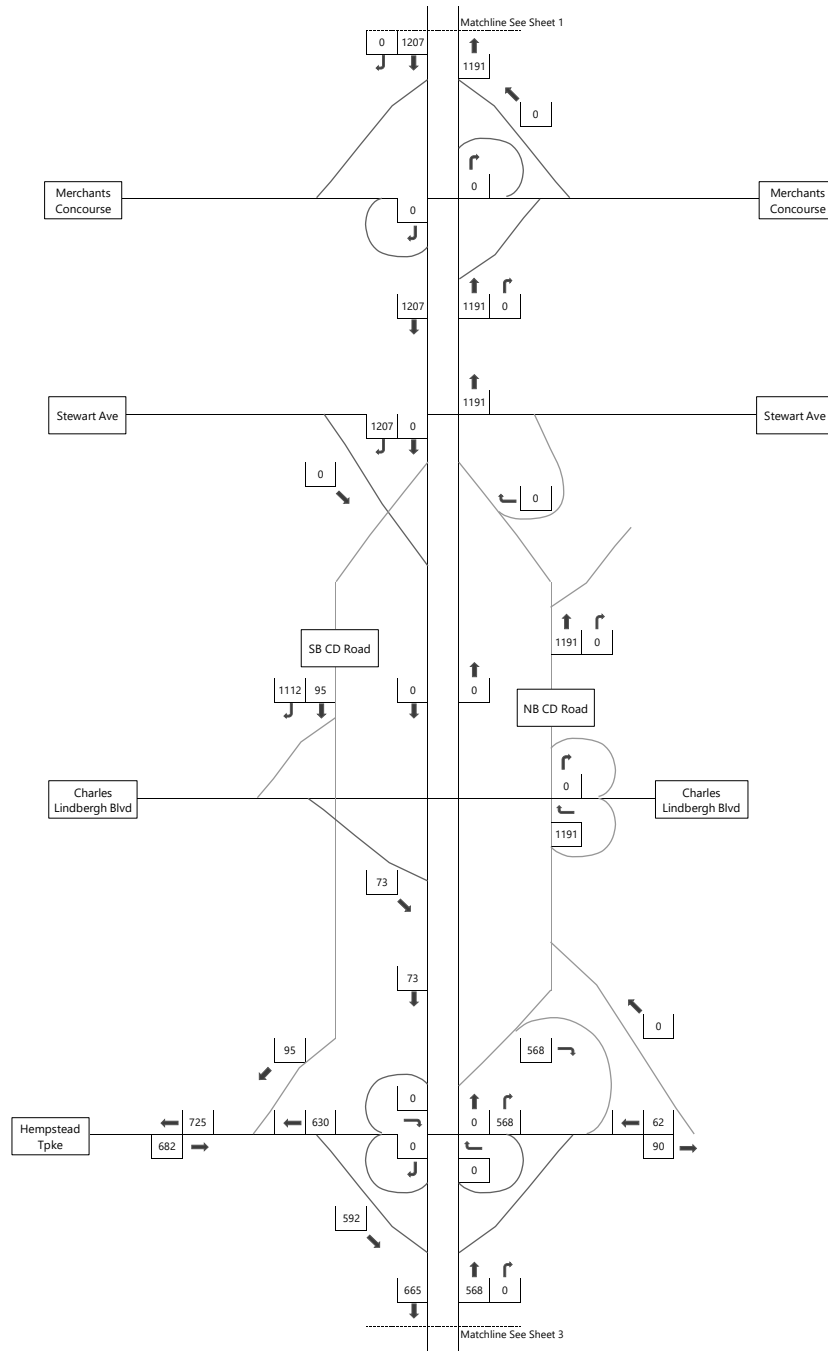

Figure V-D-5, Sheet 2
 2030 Combined Trip Assignment
 Saturday Evening Peak Hour
 26841.01 - Sands New York Integrated Resort
 Meadowbrook State Parkway



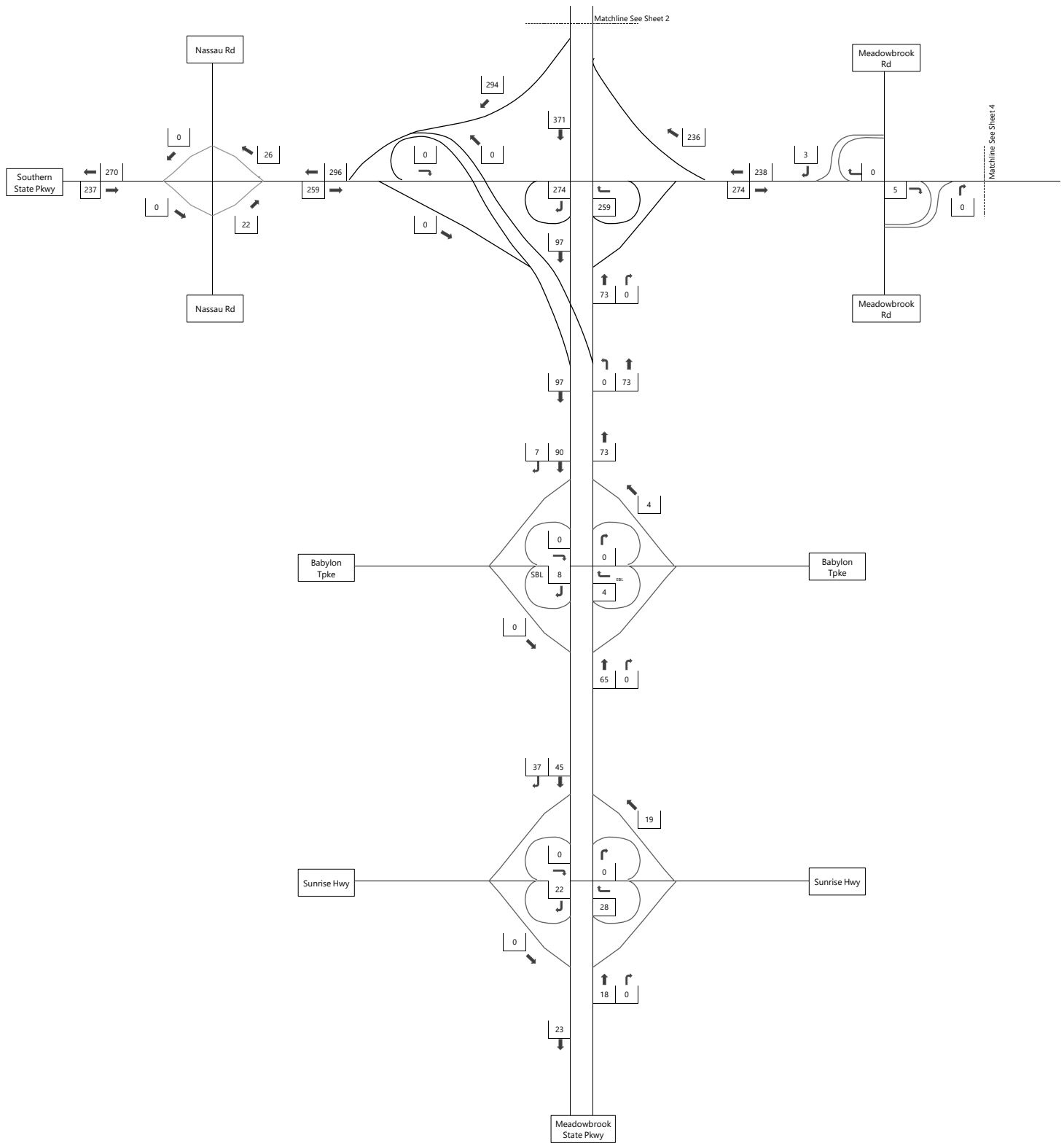

Figure V-D-5, Sheet 3
 2030 Combined Trip Assignment
 Saturday Evening Peak Hour
 26841.01 - Sands New York Integrated Resort
 Meadowbrook State Parkway



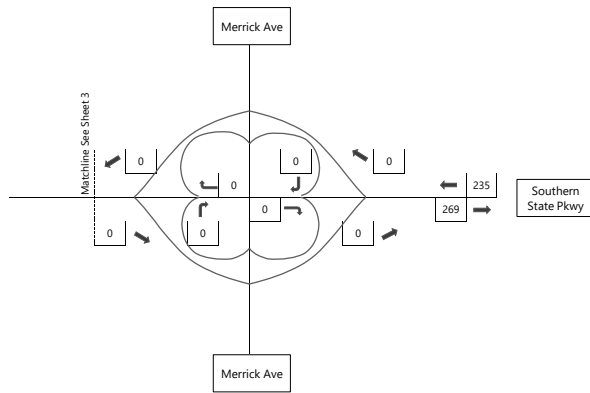
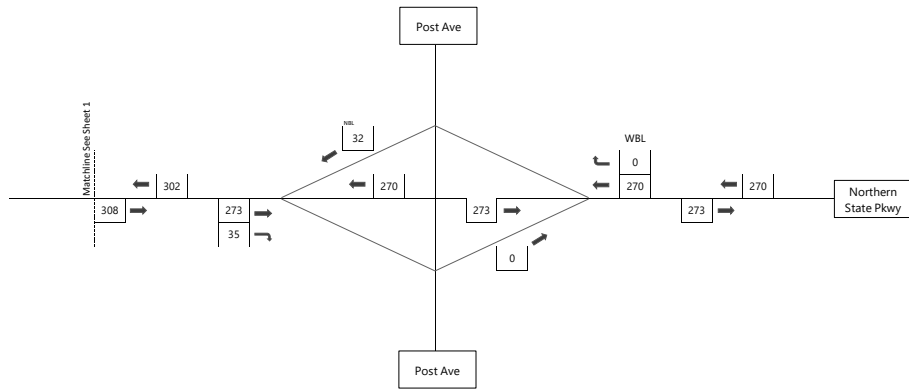

Figure V-D-5, Sheet 4
 2030 Combined Trip Assignment
 Saturday Evening Peak Hour
 26841.01 - Sands New York Integrated Resort
 Meadowbrook State Parkway



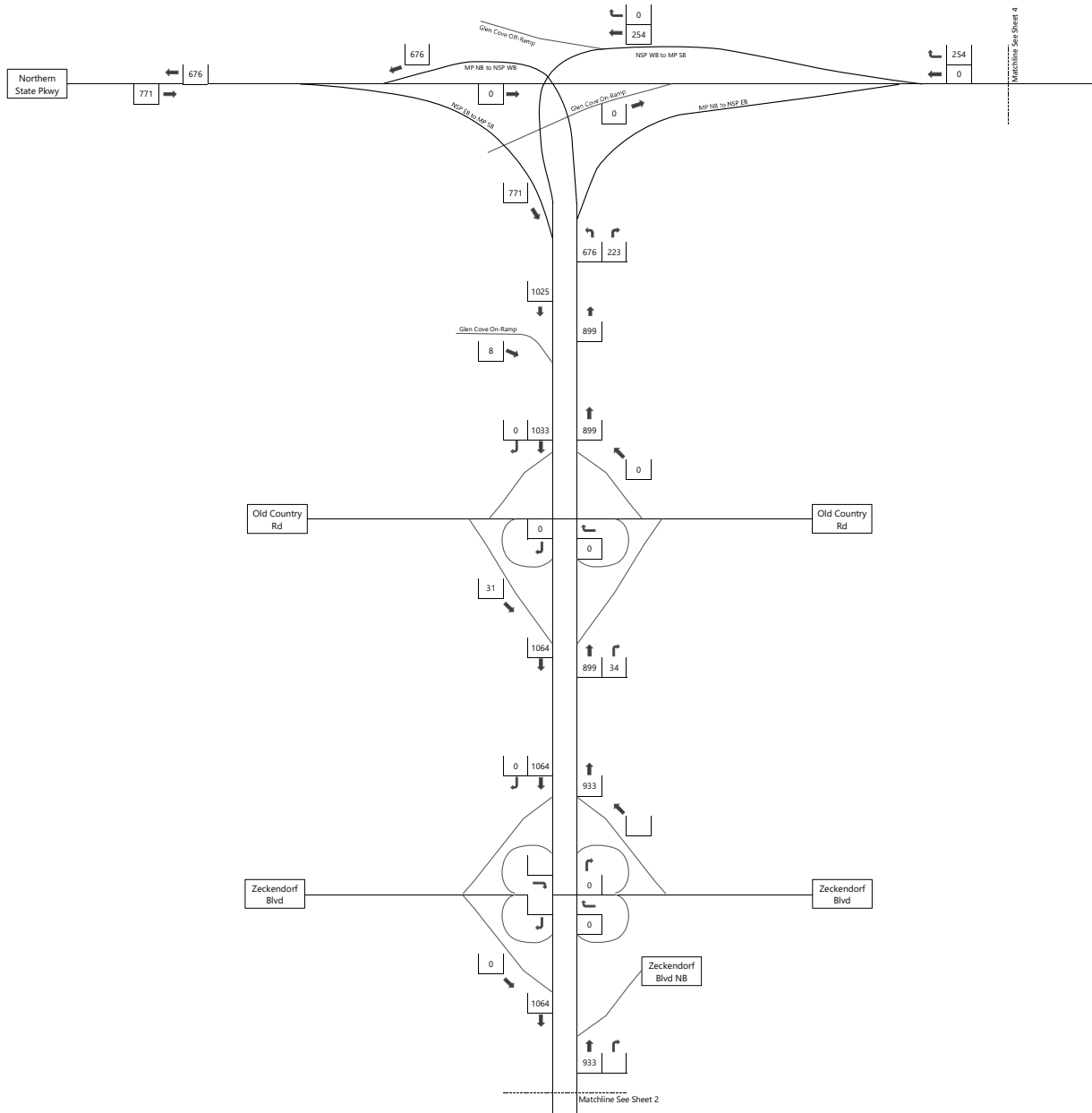

Figure V-D-5-1, Sheet 1
 2030 Trip Assignment - Casino/Hotel
 Saturday Evening Peak Hour
 26841.01 - Sands New York Integrated Resort
 Meadowbrook State Parkway



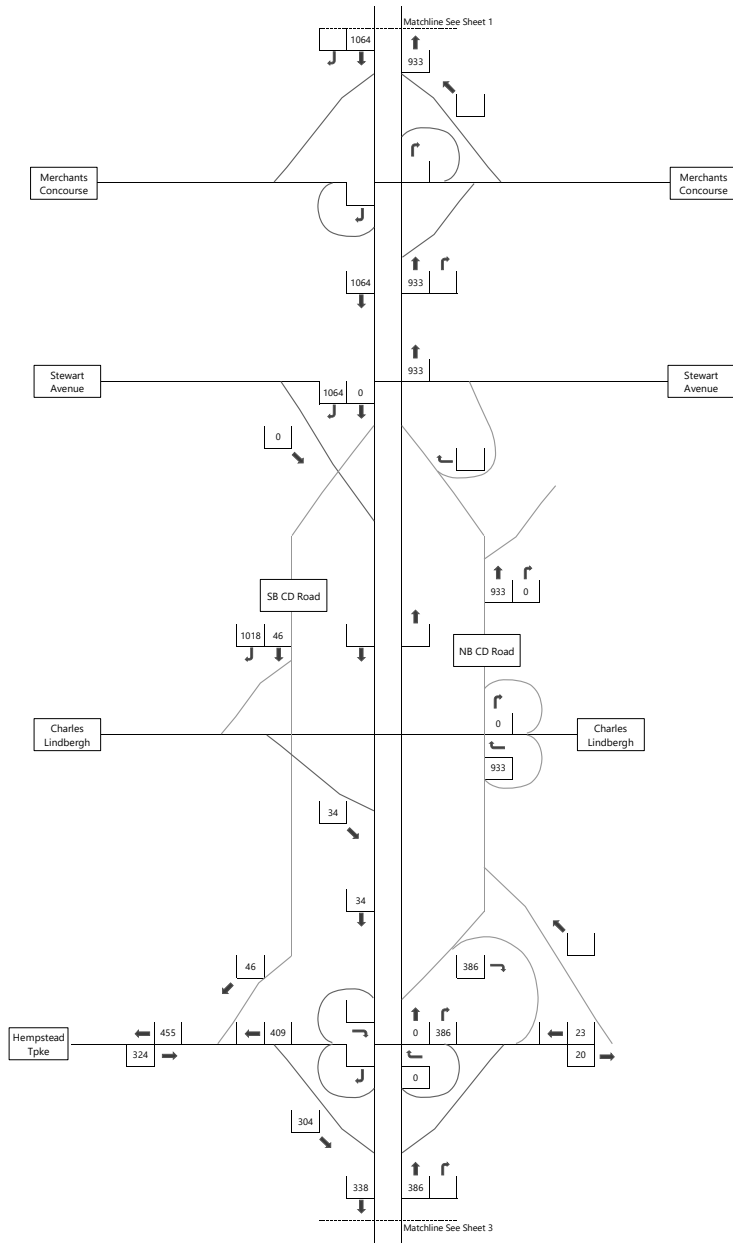

Figure V-D-5-1, Sheet 2
 2030 Trip Assignment - Casino/Hotel
 Saturday Evening Peak Hour
 26841.01 - Sands New York Integrated Resort
 Meadowbrook State Parkway



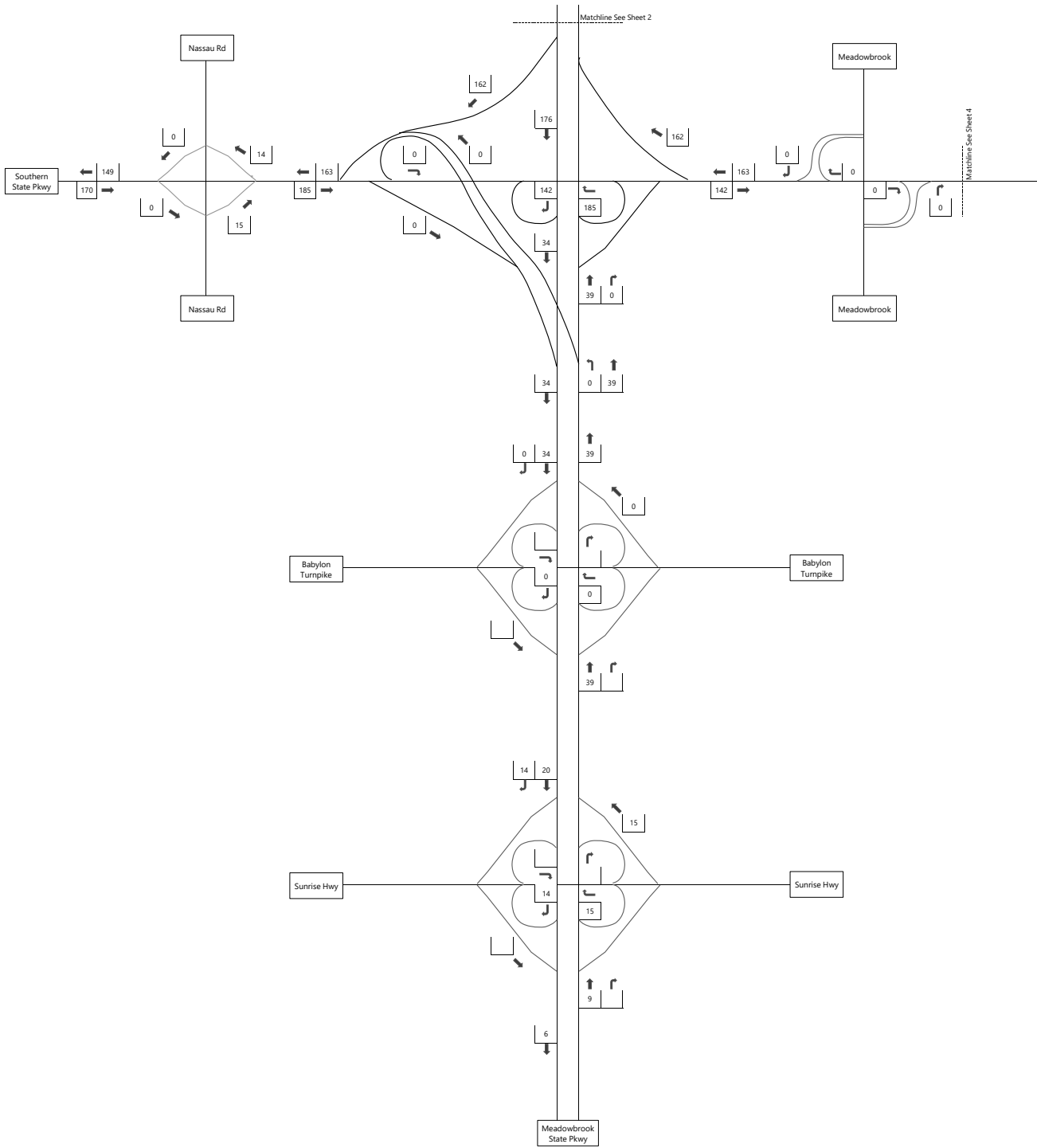

Figure V-D-5-1, Sheet 3
 2030 Trip Assignment - Casino/Hotel
 Saturday Evening Peak Hour
 26841.01 - Sands New York Integrated Resort
 Meadowbrook State Parkway



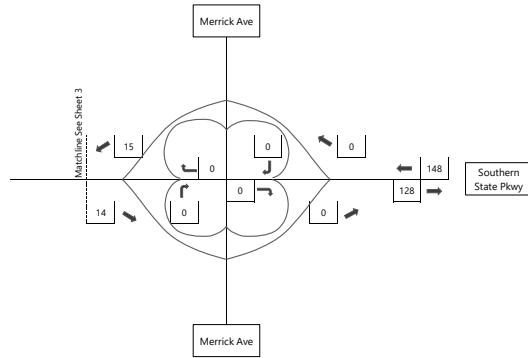
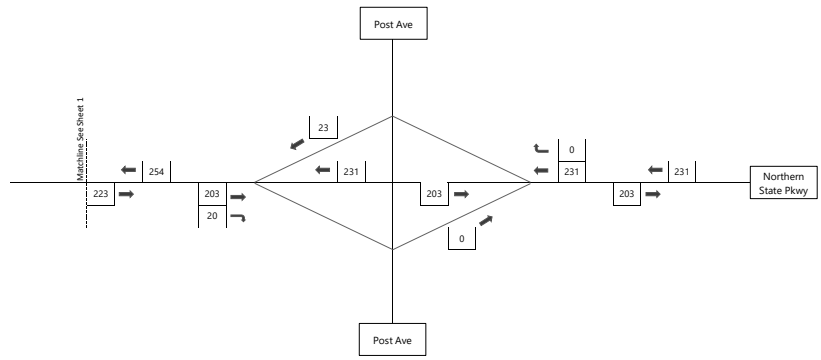

Figure V-D-5-1, Sheet 4
 2030 Trip Assignment - Casino/Hotel
 Saturday Evening Peak Hour
 26841.01 - Sands New York Integrated Resort
 Meadowbrook State Parkway



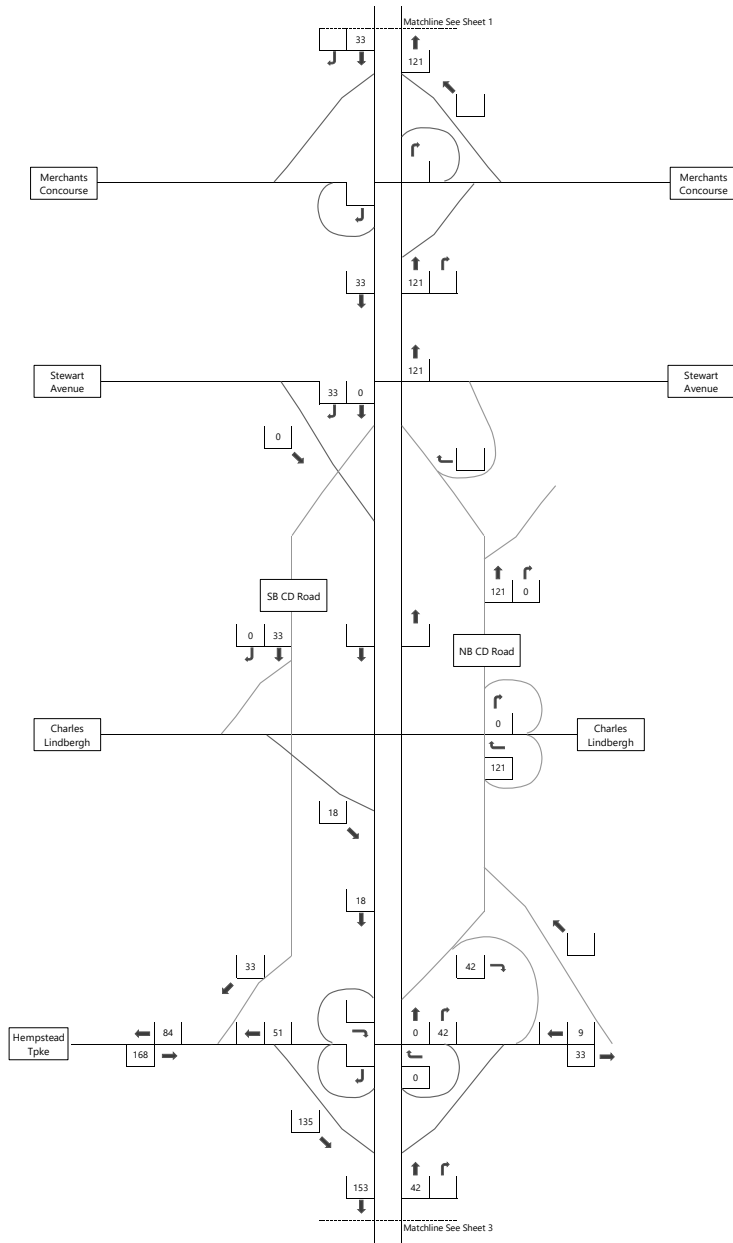

Figure V-D-5-2, Sheet 2
 2030 Trip Assignment - Employee
 Saturday Evening Peak Hour
 26841.01 - Sands New York Integrated Resort
 Meadowbrook State Parkway



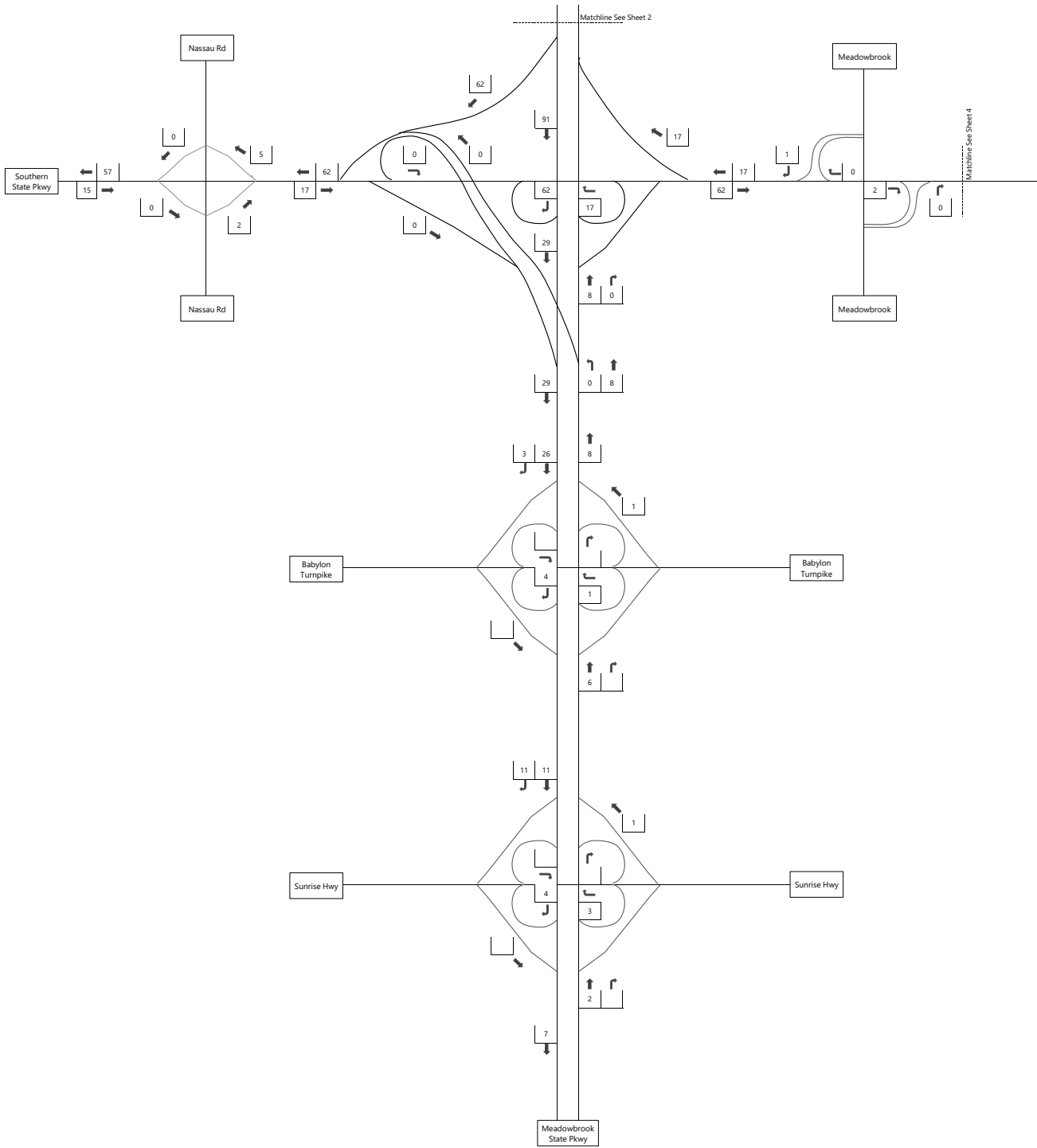

Figure V-D-5-2, Sheet 3
 2030 Trip Assignment - Employee
 Saturday Evening Peak Hour
 26841.01 - Sands New York Integrated Resort
 Meadowbrook State Parkway



Not to Scale



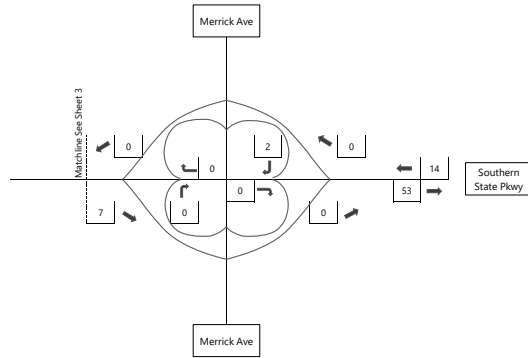
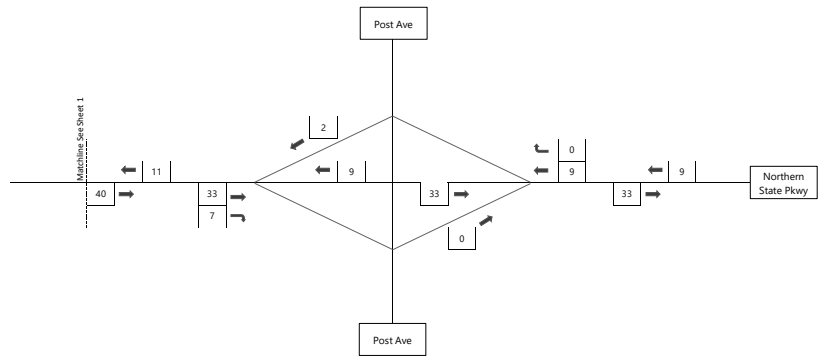

Figure V-D-5-2, Sheet 4
 2030 Trip Assignment - Employee
 Saturday Evening Peak Hour
 26841.01 - Sands New York Integrated Resort
 Meadowbrook State Parkway



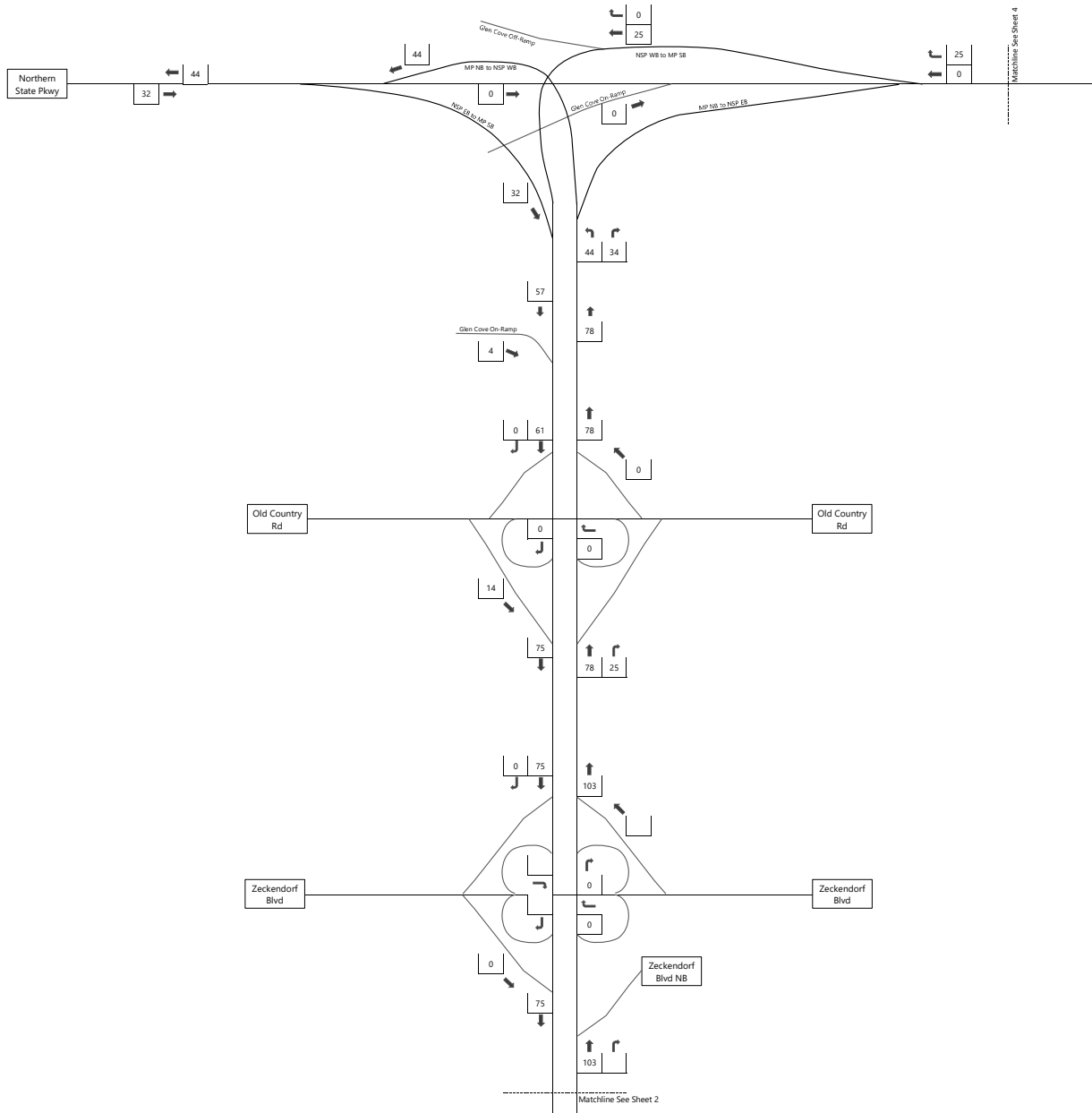

Figure V-D-5-3, Sheet 1
 2030 Trip Assignment - Restaurant/Retail/Public Attraction,
 Theater, Meetings and Conference
 Saturday Evening Peak Hour
 26841.01 - Sands New York Integrated Resort
 Meadowbrook State Parkway



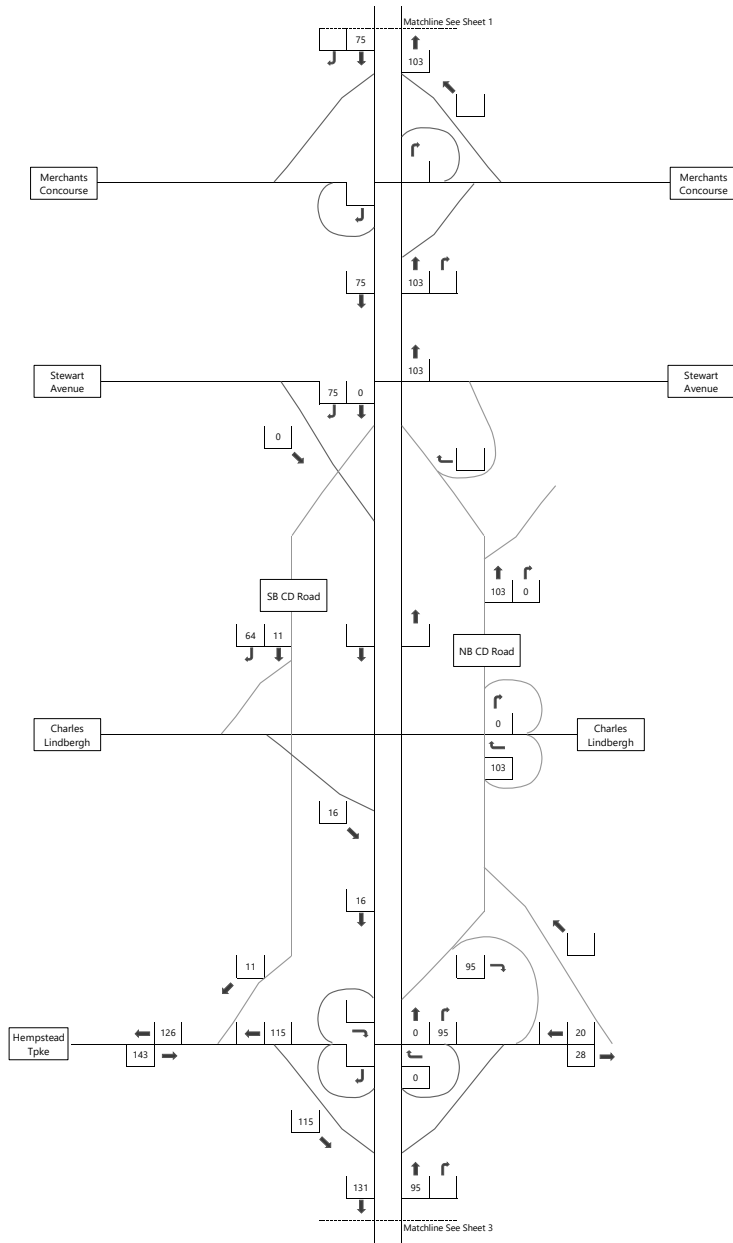

Figure V-D-5-3, Sheet 2
 2030 Trip Assignment - Restaurant/Retail/Public Attraction,
 Theater, Meetings and Conference
 Saturday Evening Peak Hour
 26841.01 - Sands New York Integrated Resort
 Meadowbrook State Parkway



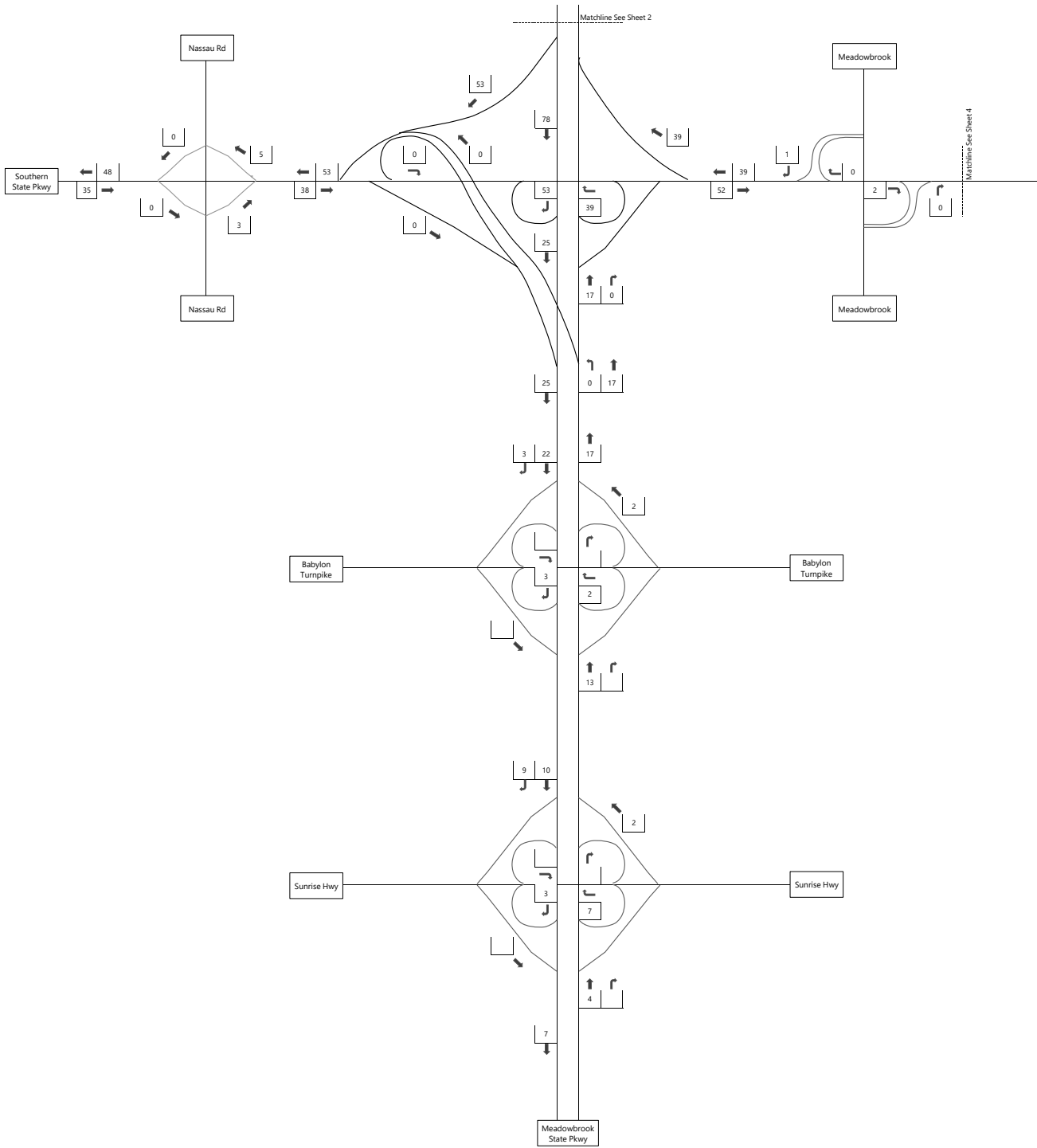

Figure V-D-5-3, Sheet 3
 2030 Trip Assignment - Restaurant/Retail/Public Attraction,
 Theater, Meetings and Conference
 Saturday Evening Peak Hour
 26841.01 - Sands New York Integrated Resort
 Meadowbrook State Parkway



Not to Scale



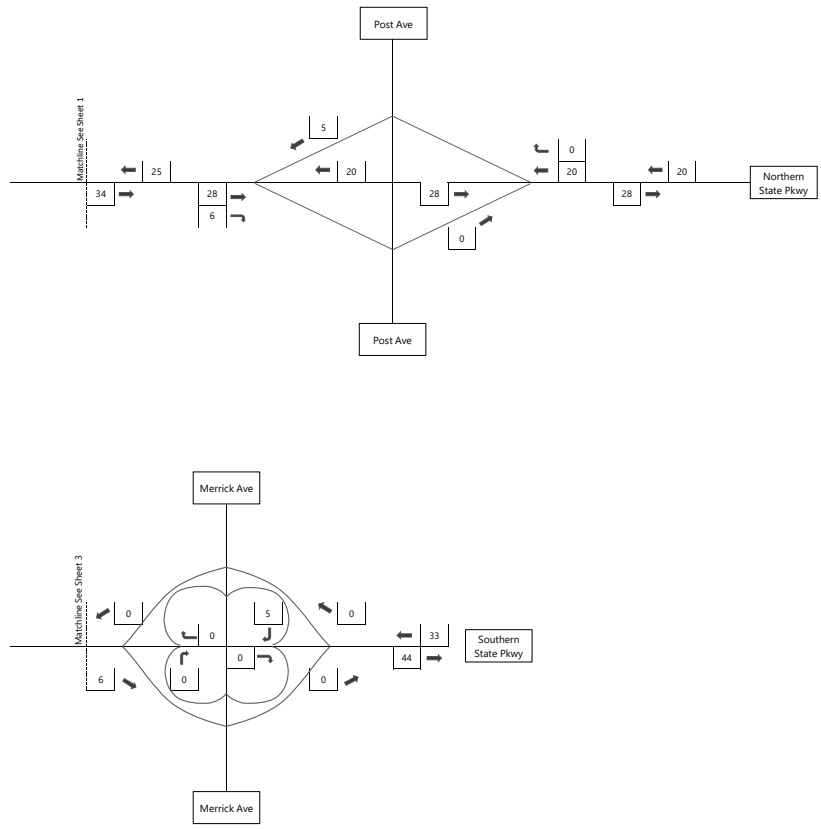

Figure V-D-5-3, Sheet 4
 2030 Trip Assignment - Restaurant/Retail/Public Attraction,
 Theater, Meetings and Conference
 Saturday Evening Peak Hour
 26841.01 - Sands New York Integrated Resort
 Meadowbrook State Parkway



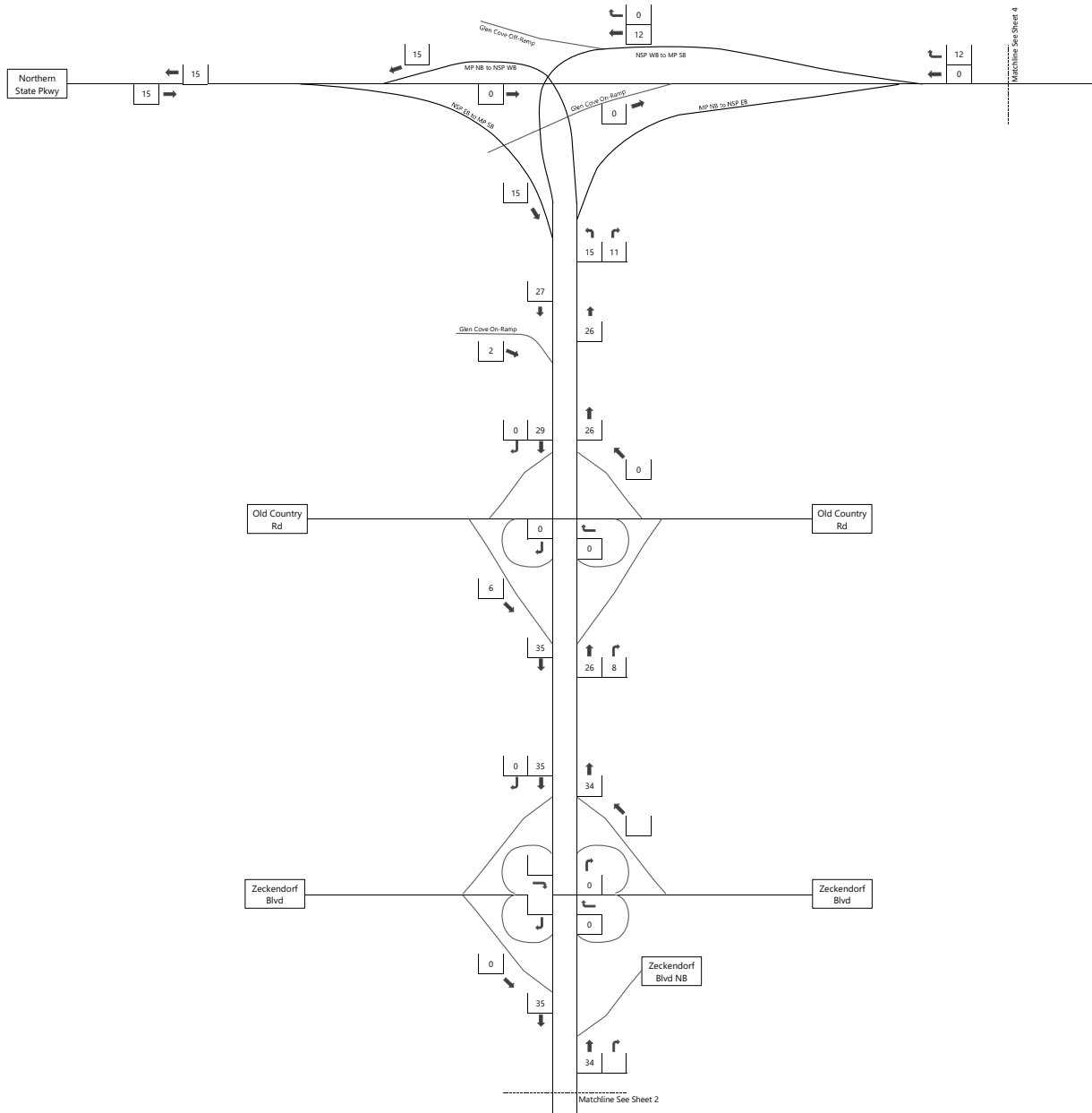

Figure V-D-5-4, Sheet 1
 2030 Trip Assignment - Ridehailing
 Saturday Evening Peak Hour
 26841.01 - Sands New York Integrated Resort
 Meadowbrook State Parkway



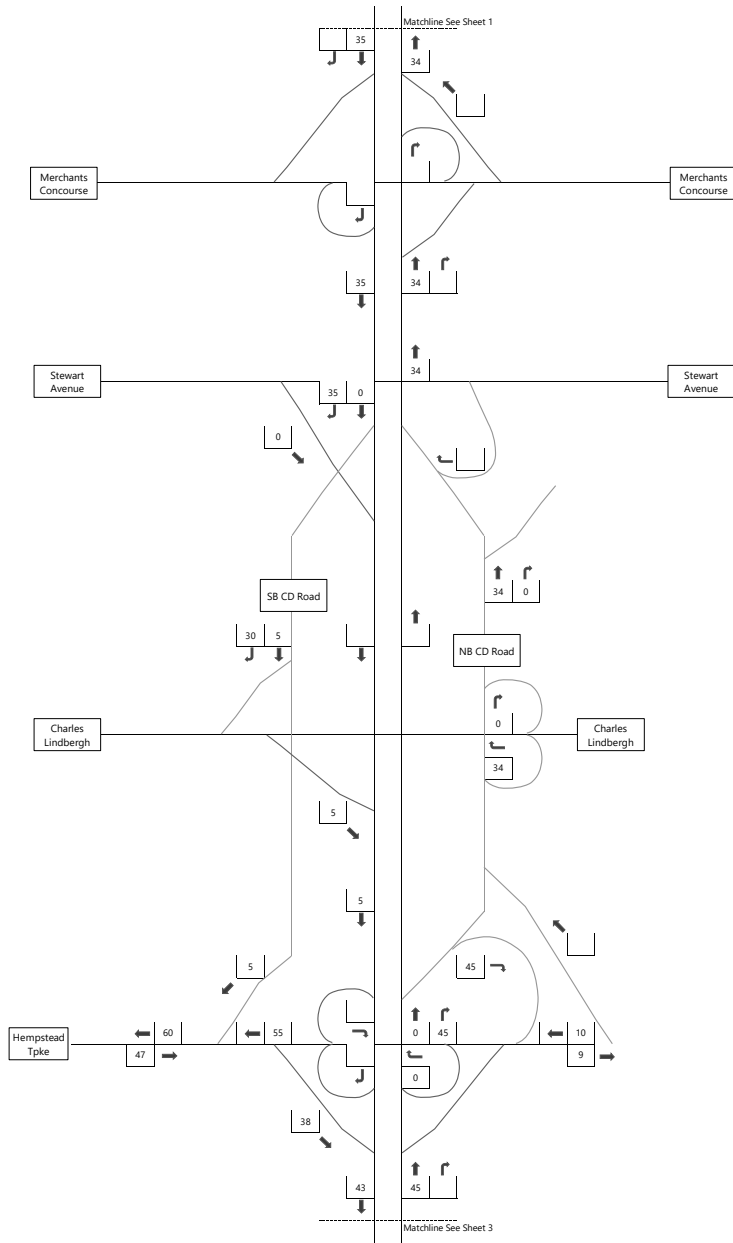

Figure V-D-5-4, Sheet 2
 2030 Trip Assignment - Ridehailing
 Saturday Evening Peak Hour
 26841.01 - Sands New York Integrated Resort
 Meadowbrook State Parkway



Not to Scale



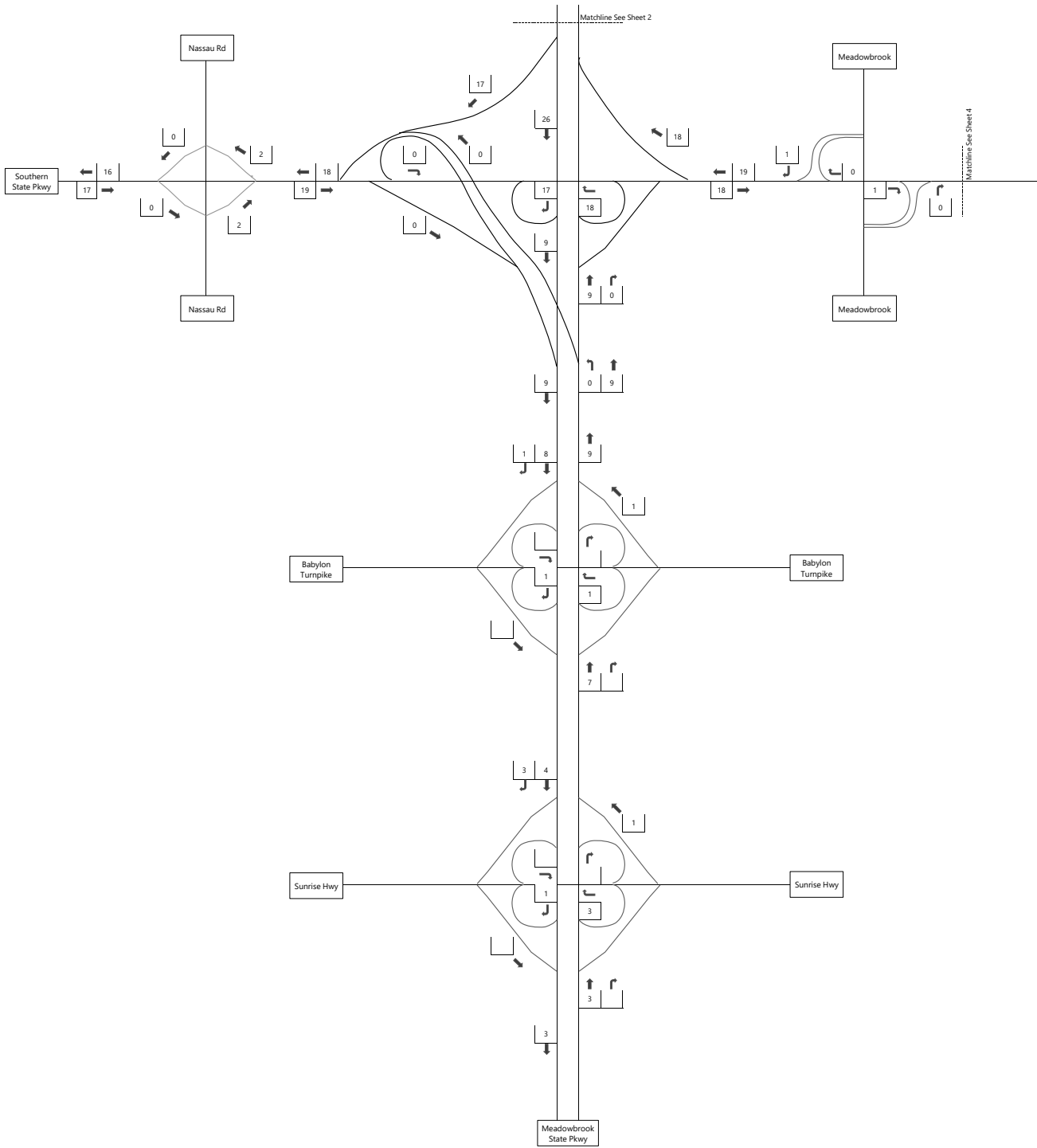

Figure V-D-5-4, Sheet 3
 2030 Trip Assignment - Ridehailing
 Saturday Evening Peak Hour
 26841.01 - Sands New York Integrated Resort
 Meadowbrook State Parkway



Not to Scale



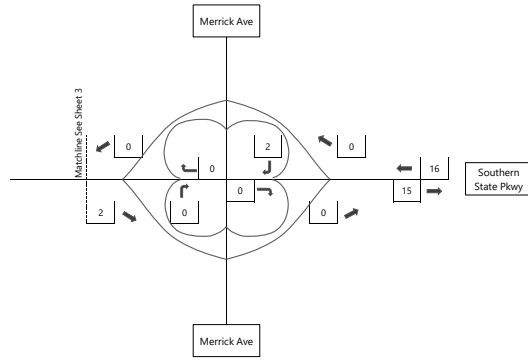
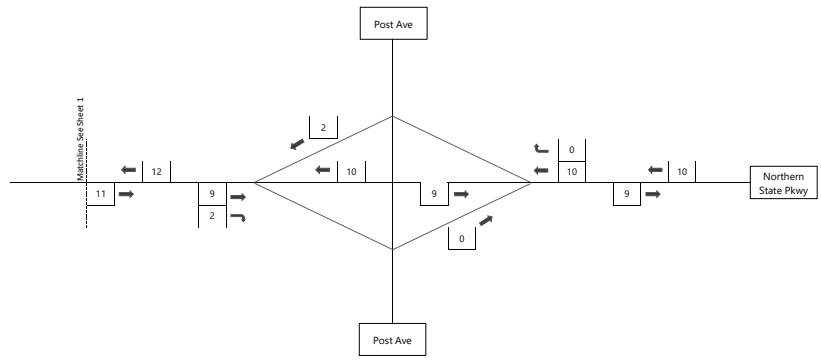

Figure V-D-5-4, Sheet 4
 2030 Trip Assignment - Ridehailing
 Saturday Evening Peak Hour
 26841.01 - Sands New York Integrated Resort
 Meadowbrook State Parkway





2030 Full Build

V-E 2030 Build Traffic Volumes

**26841.01: Sands Integrated Resort
Traffic Impact Study Attachments
Attachment F – Parkway Peak Hour Traffic Volume Figures**



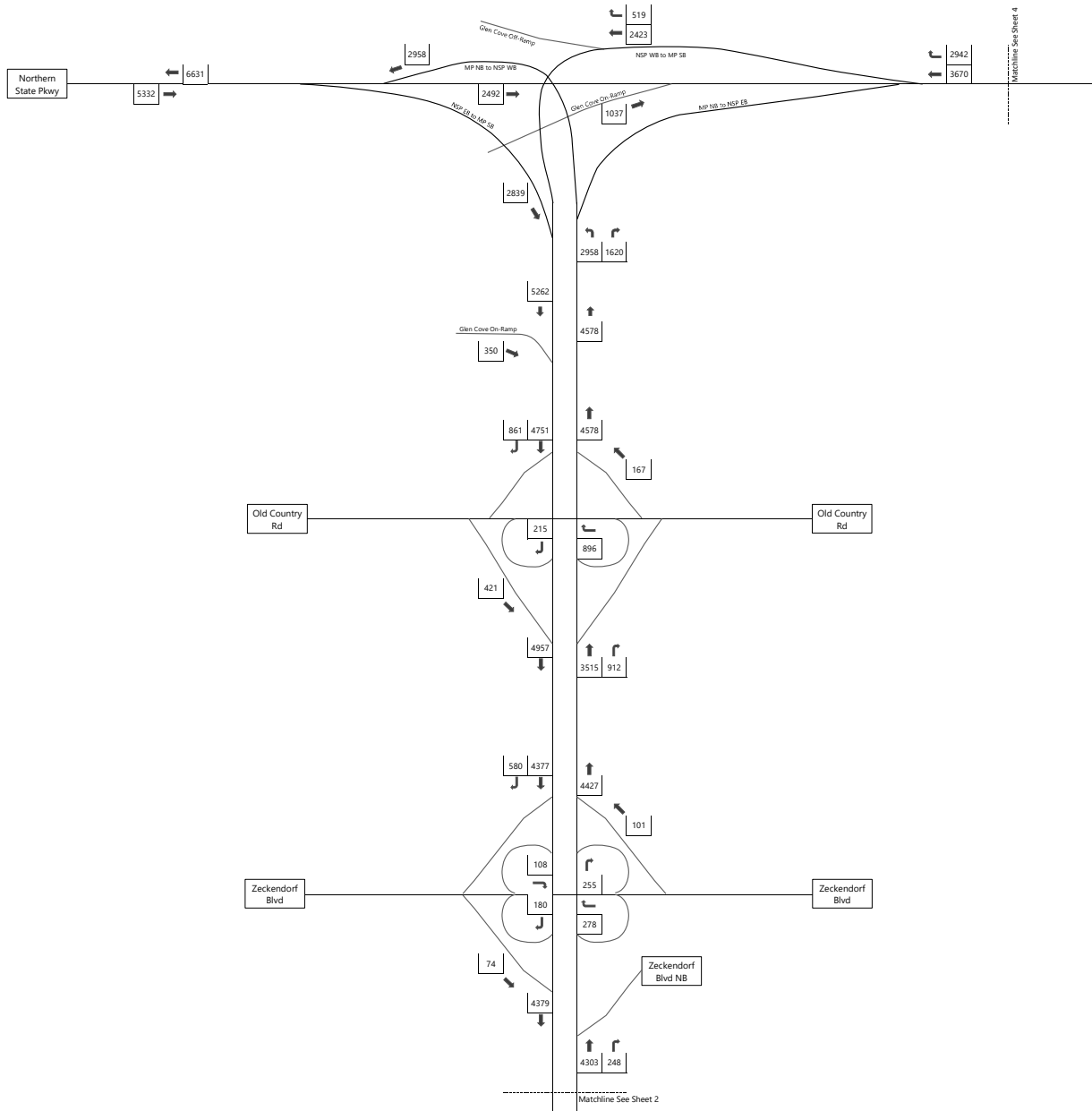

Figure V-E-1, Sheet 1
 2030 Build Parkway Traffic Volumes
 Weekday AM Peak Hour
 26841.01 - Sands New York Integrated Resort
 Meadowbrook State Parkway



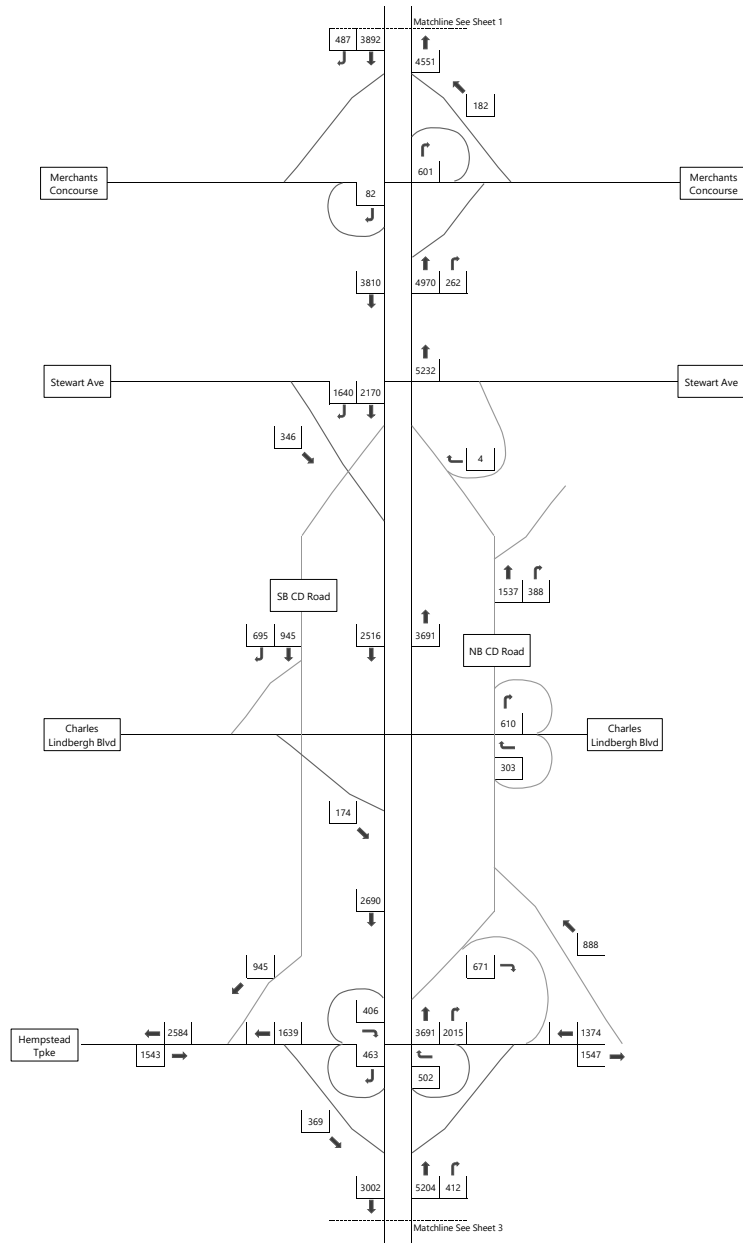

Figure V-E-1, Sheet 2
 2030 Build Parkway Traffic Volumes
 Weekday AM Peak Hour
 26841.01 - Sands New York Integrated Resort
 Meadowbrook State Parkway



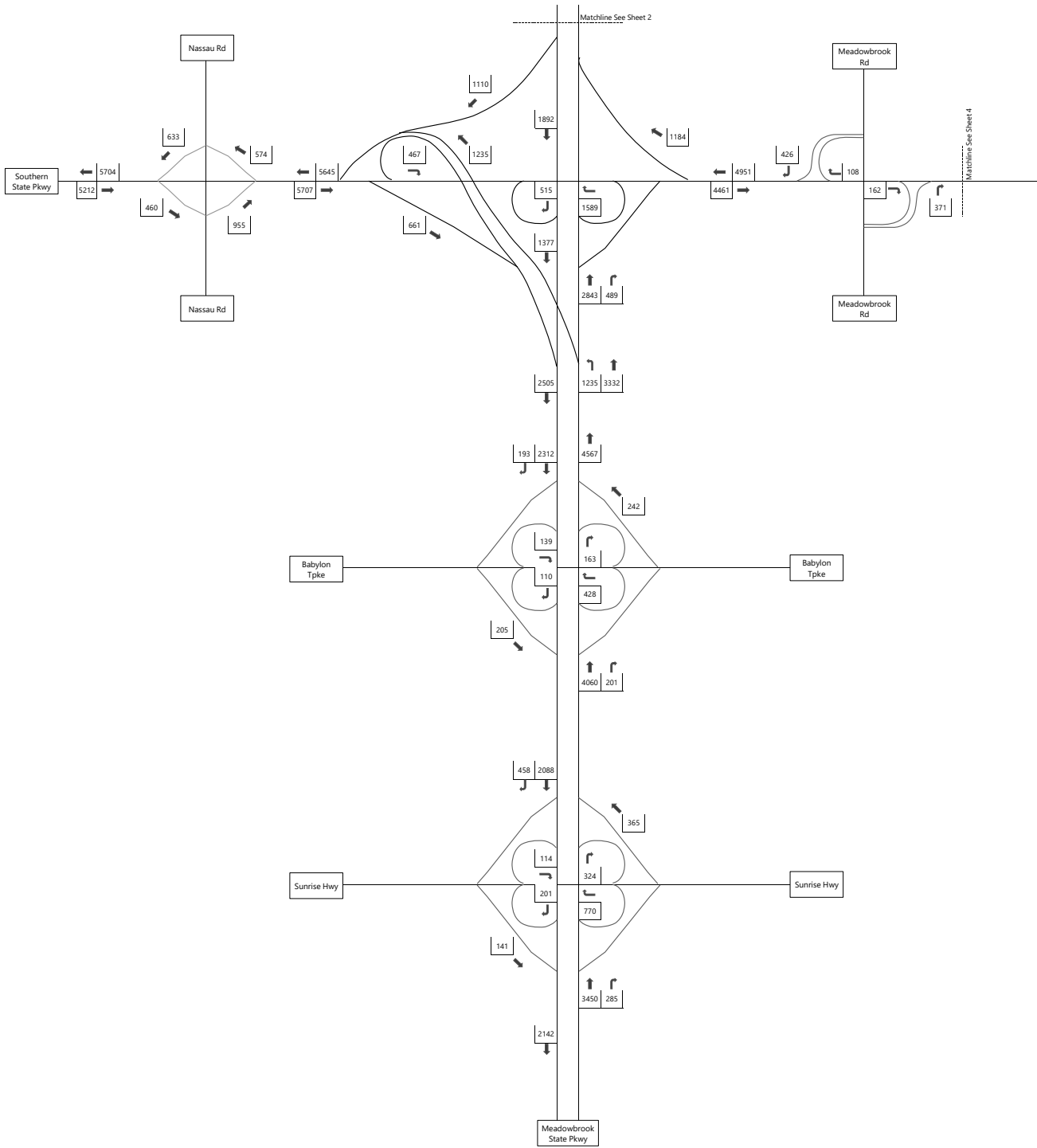

Figure V-E-1, Sheet 3
 2030 Build Parkway Traffic Volumes
 Weekday AM Peak Hour
 26841.01 - Sands New York Integrated Resort
 Meadowbrook State Parkway



Not to Scale



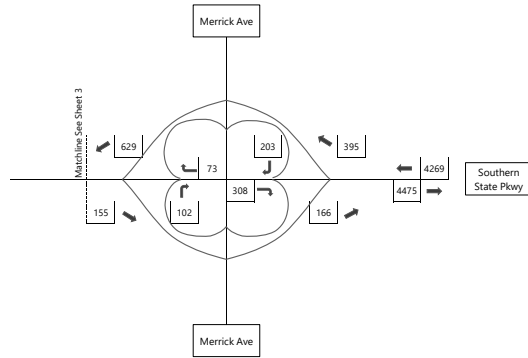
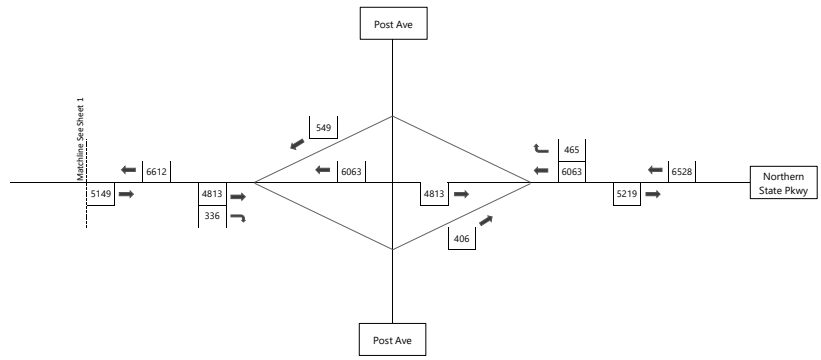

Figure V-E-1, Sheet 4
 2030 Build Parkway Traffic Volumes
 Weekday AM Peak Hour
 26841.01 - Sands New York Integrated Resort
 Meadowbrook State Parkway



Not to Scale



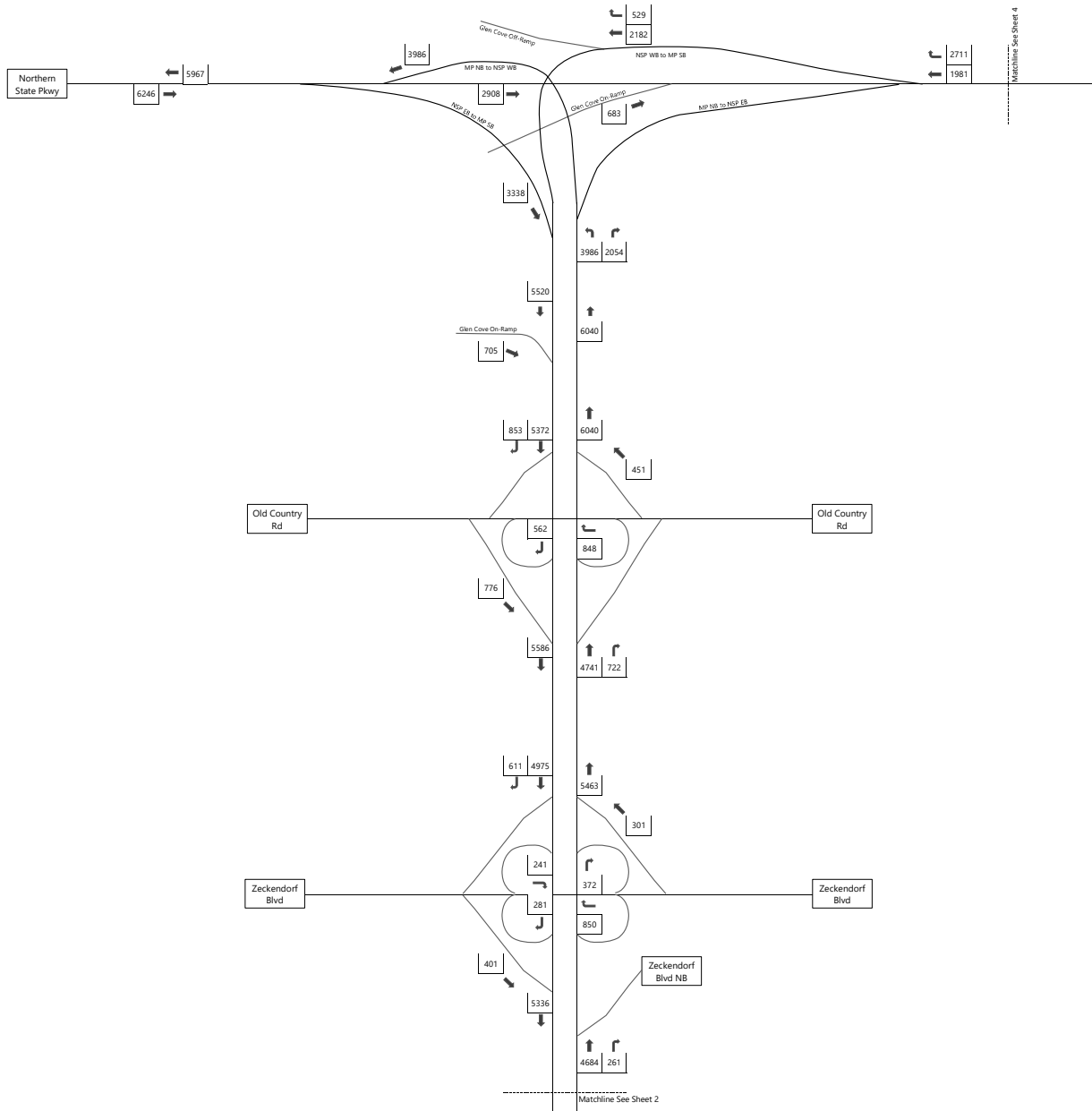

Figure V-E-2, Sheet 1
 2030 Build Parkway Traffic Volumes
 Weekday PM Peak Hour
 26841.01 - Sands New York Integrated Resort
 Meadowbrook State Parkway



Not to Scale



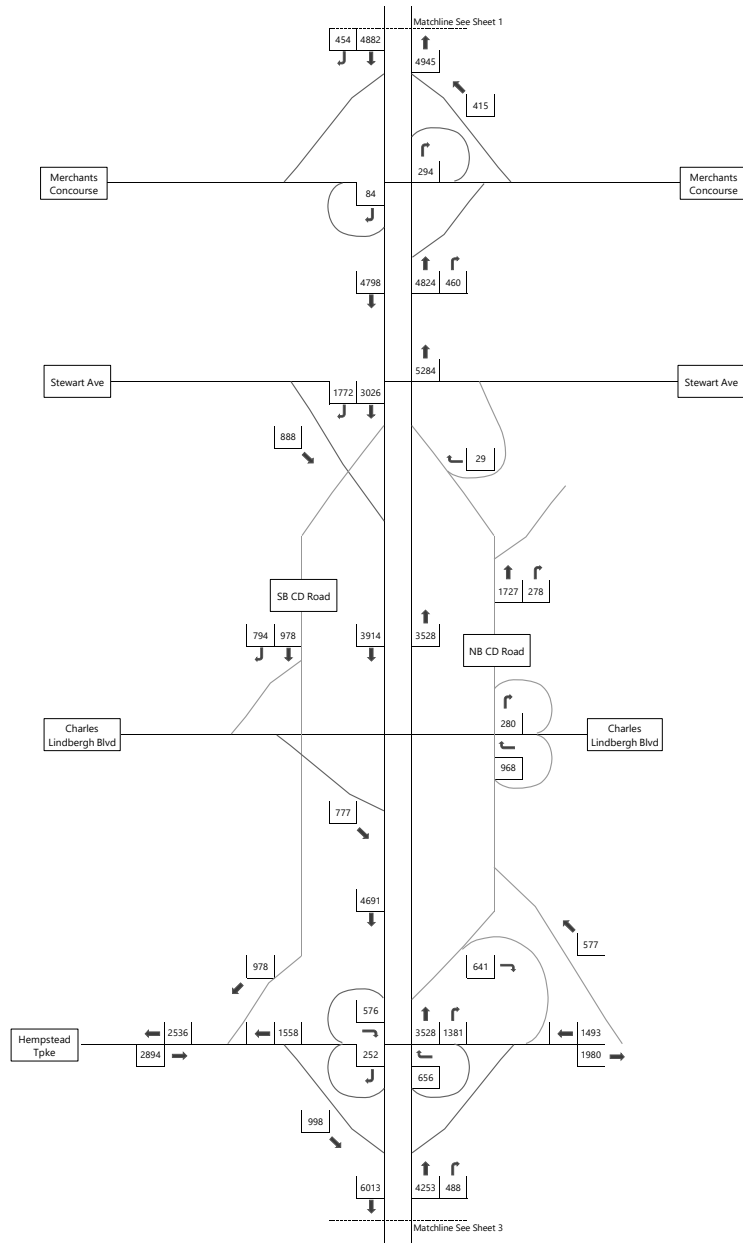

Figure V-E-2, Sheet 2
 2030 Build Parkway Traffic Volumes
 Weekday PM Peak Hour
 26841.01 - Sands New York Integrated Resort
 Meadowbrook State Parkway



Not to Scale



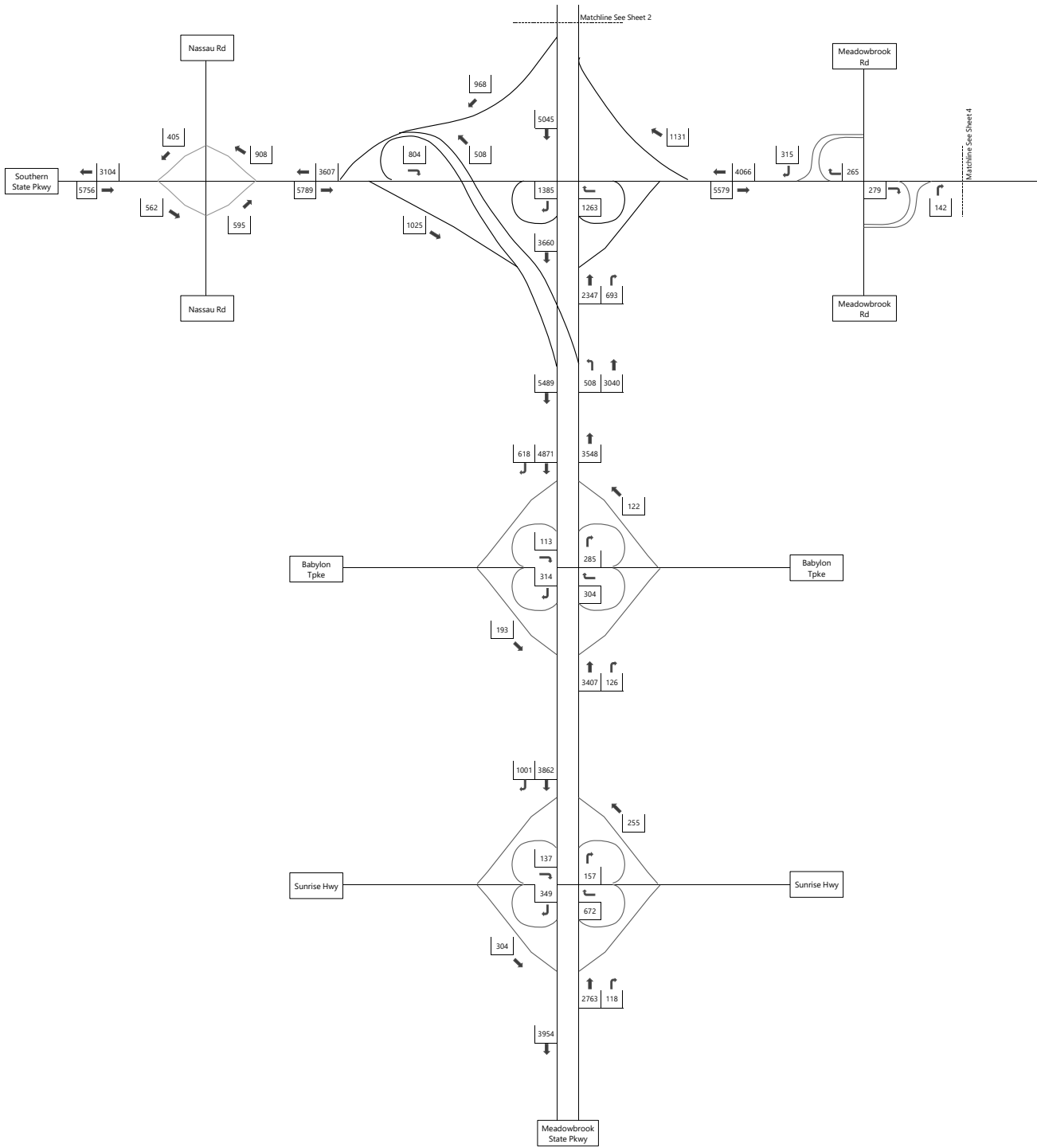

Figure V-E-2, Sheet 3
 2030 Build Parkway Traffic Volumes
 Weekday PM Peak Hour
 26841.01 - Sands New York Integrated Resort
 Meadowbrook State Parkway



Not to Scale



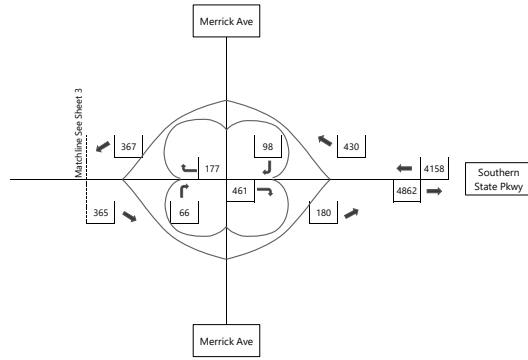
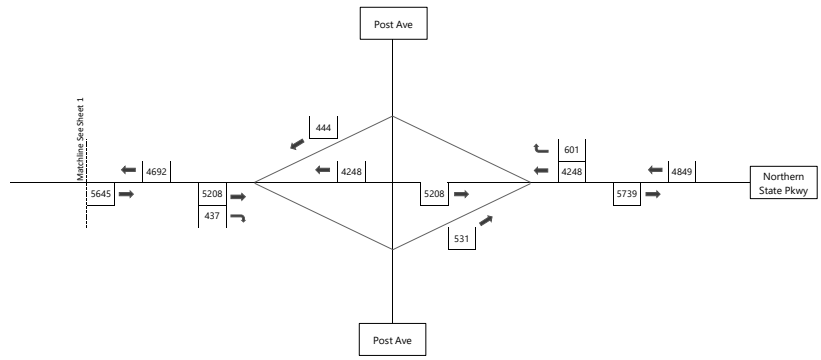

Figure V-E-2, Sheet 4
 2030 Build Parkway Traffic Volumes
 Weekday PM Peak Hour
 26841.01 - Sands New York Integrated Resort
 Meadowbrook State Parkway



Not to Scale



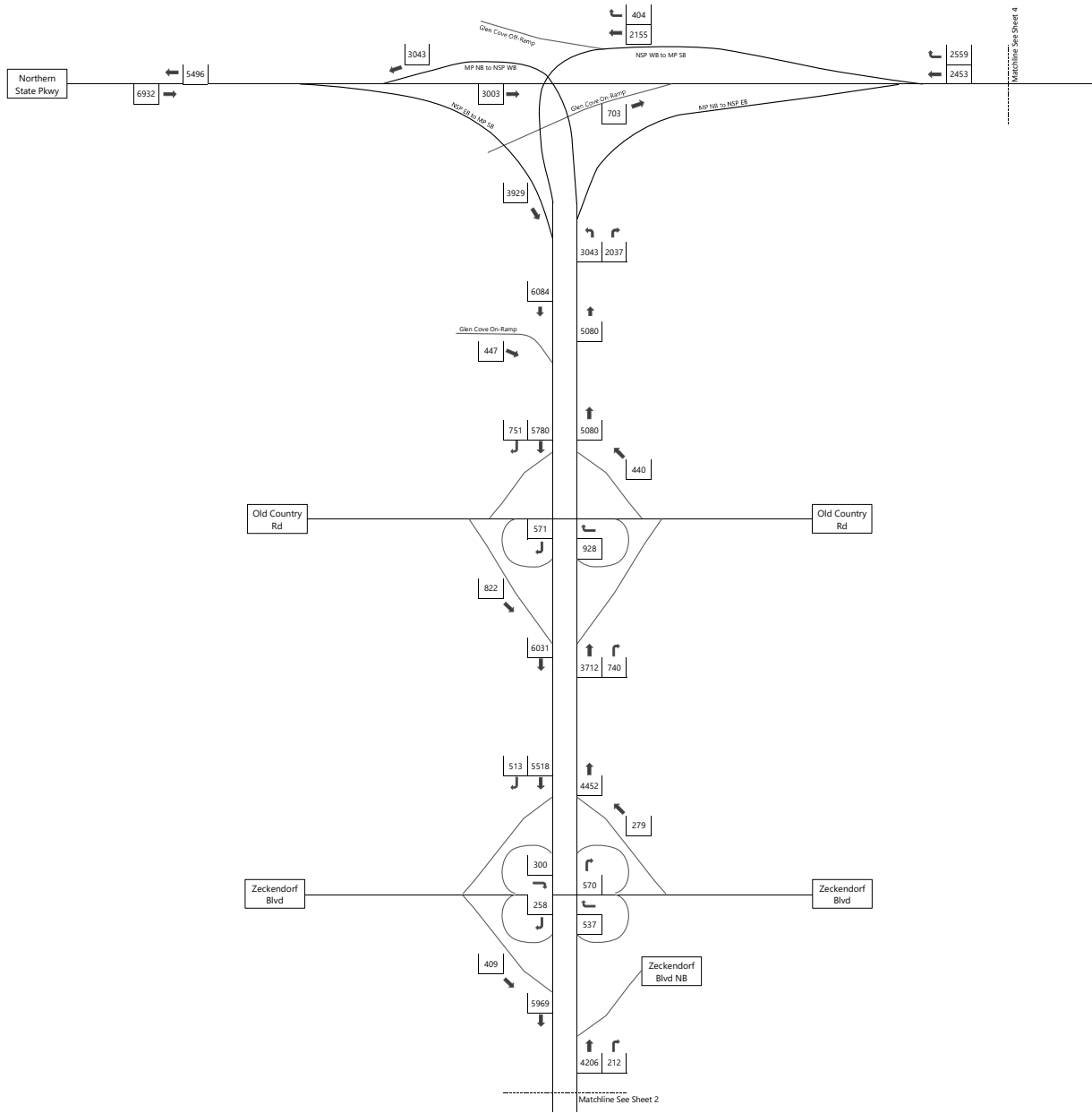

Figure V-E-3, Sheet 1
 2030 Build Parkway Traffic Volumes
 Friday Evening Peak Hour
 26841.01 - Sands New York Integrated Resort
 Meadowbrook State Parkway



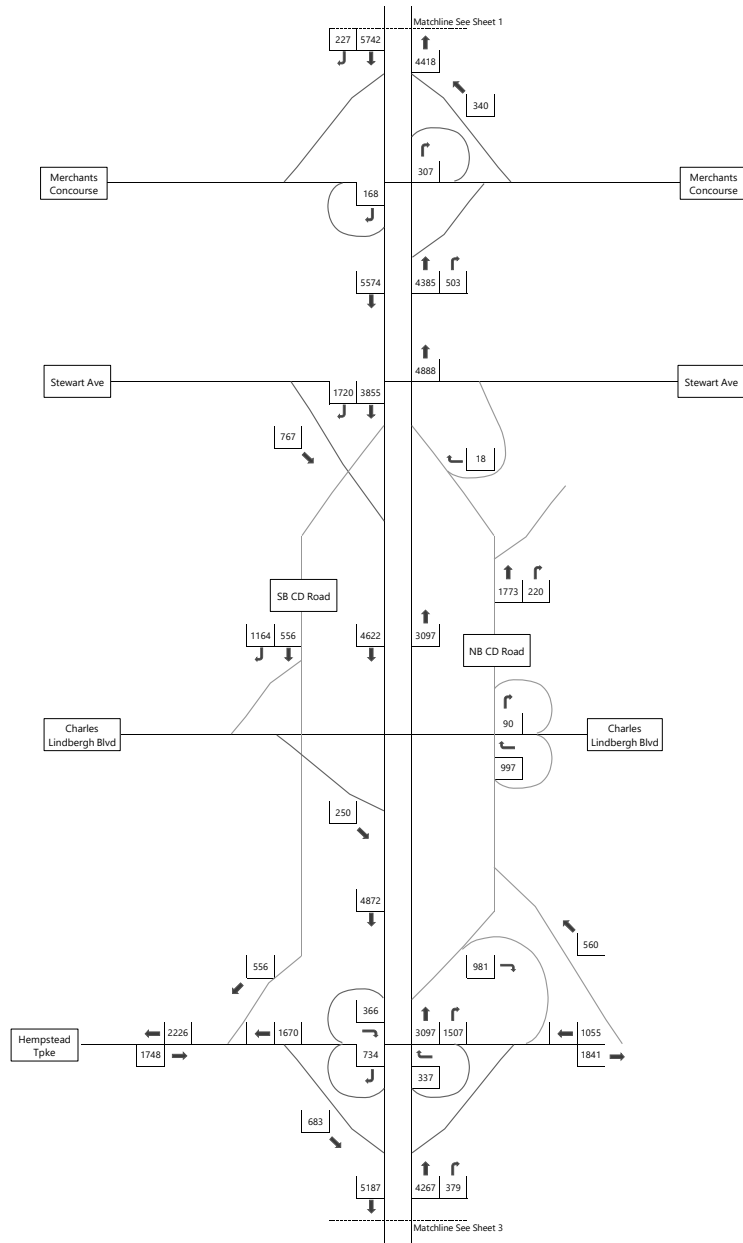

Figure V-E-3, Sheet 2
 2030 Build Parkway Traffic Volumes
 Friday Evening Peak Hour
 26841.01 - Sands New York Integrated Resort
 Meadowbrook State Parkway



Not to Scale



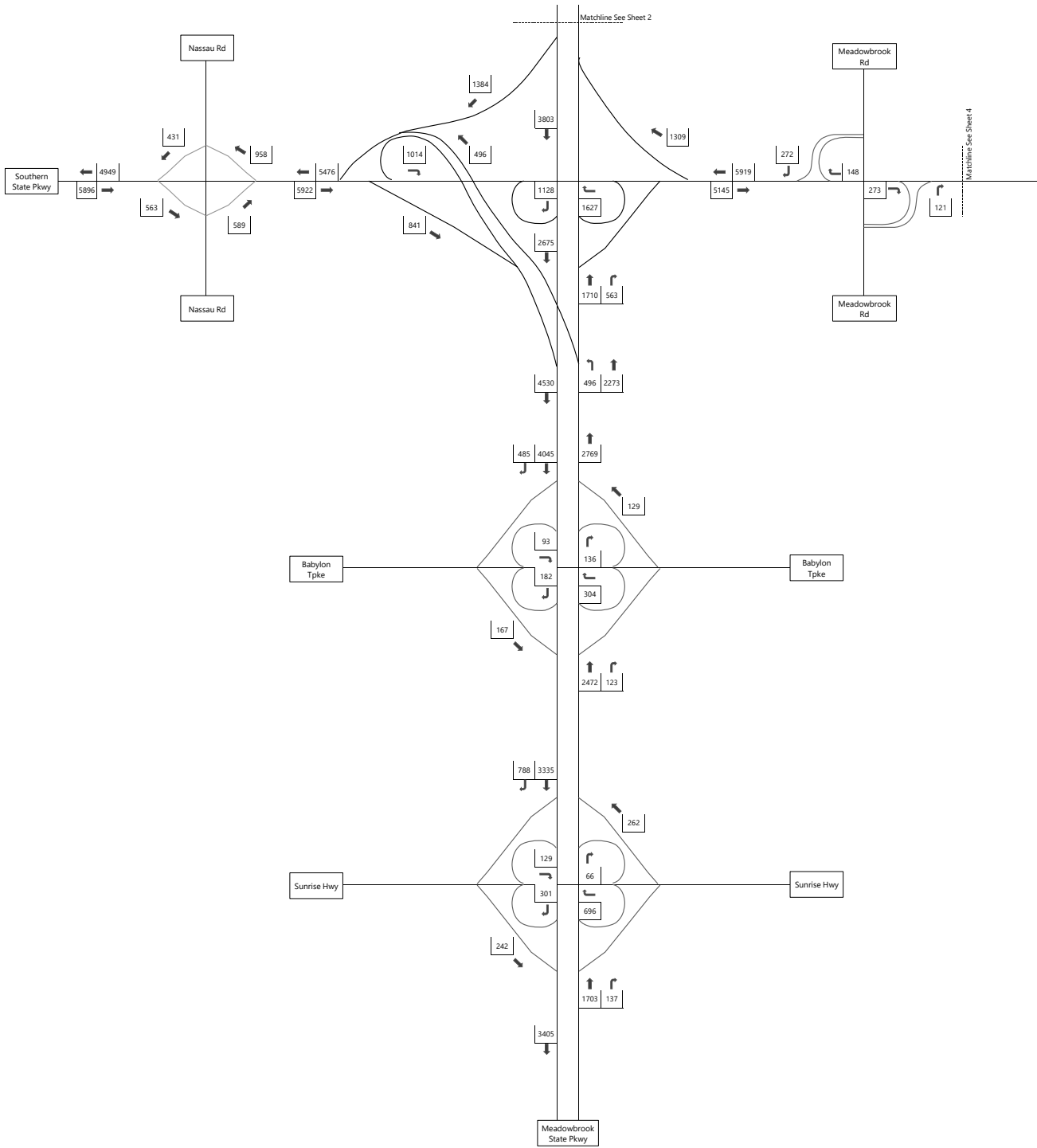

Figure V-E-3, Sheet 3
 2030 Build Parkway Traffic Volumes
 Friday Evening Peak Hour
 26841.01 - Sands New York Integrated Resort
 Meadowbrook State Parkway



Not to Scale



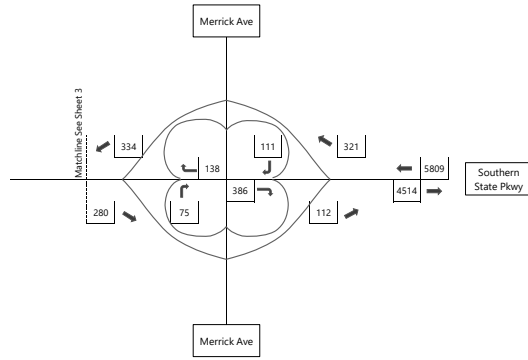
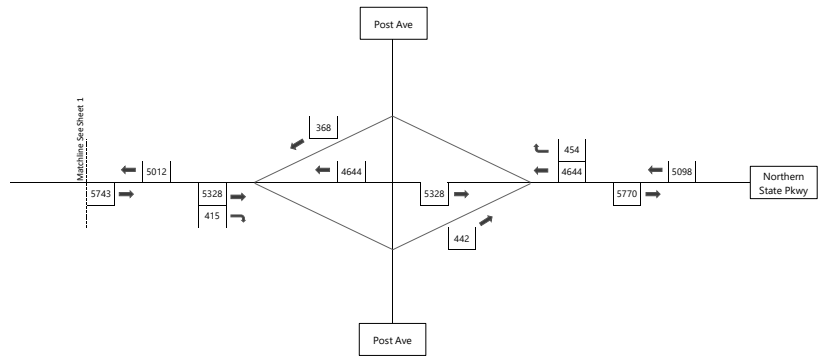

Figure V-E-3, Sheet 4
 2030 Build Parkway Traffic Volumes
 Friday Evening Peak Hour
 26841.01 - Sands New York Integrated Resort
 Meadowbrook State Parkway



Not to Scale



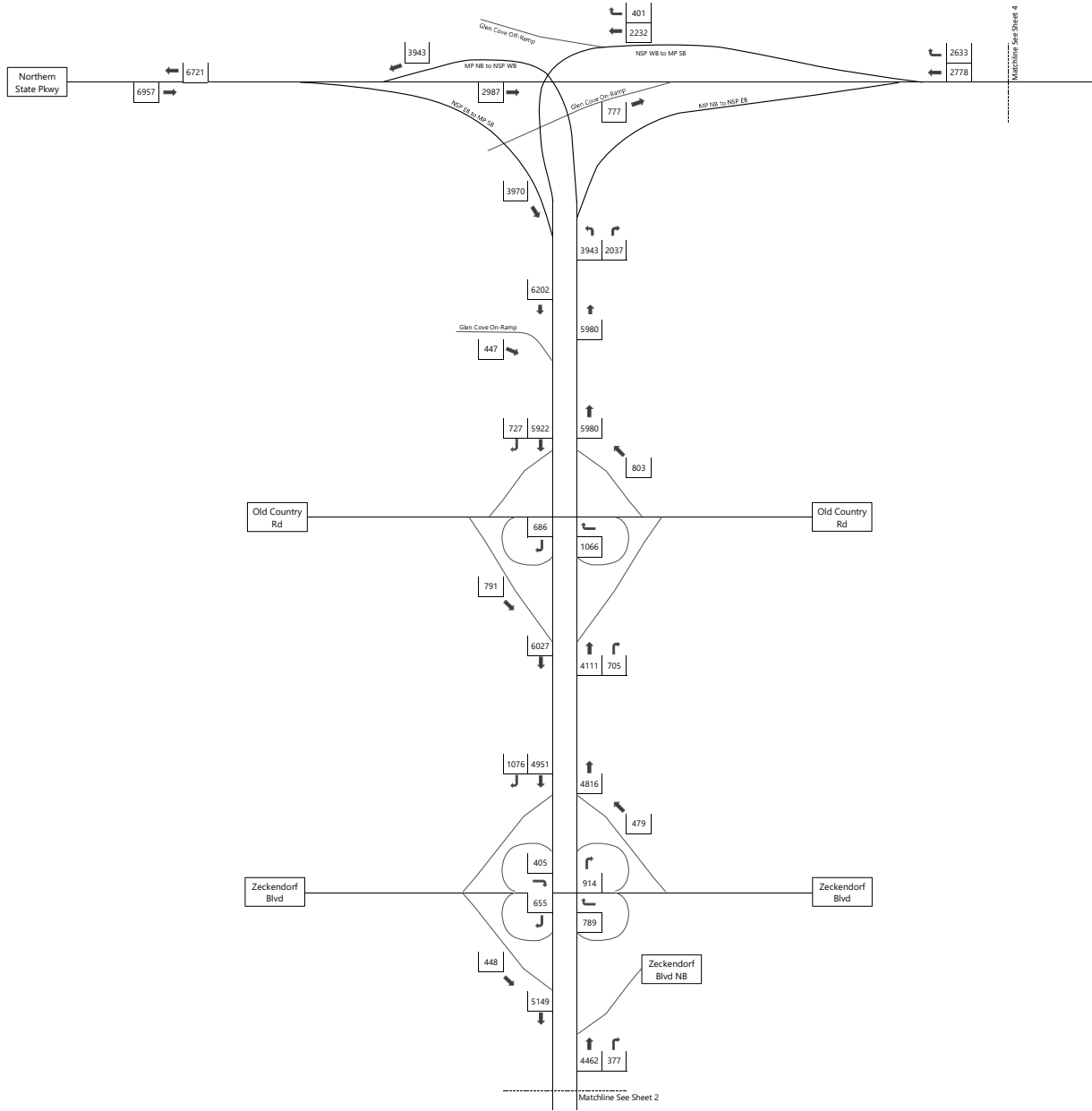

Figure V-E-4, Sheet 1
 2030 Build Parkway Traffic Volumes
 Saturday Midday Peak Hour
 26841.01 - Sands New York Integrated Resort
 Meadowbrook State Parkway



Not to Scale



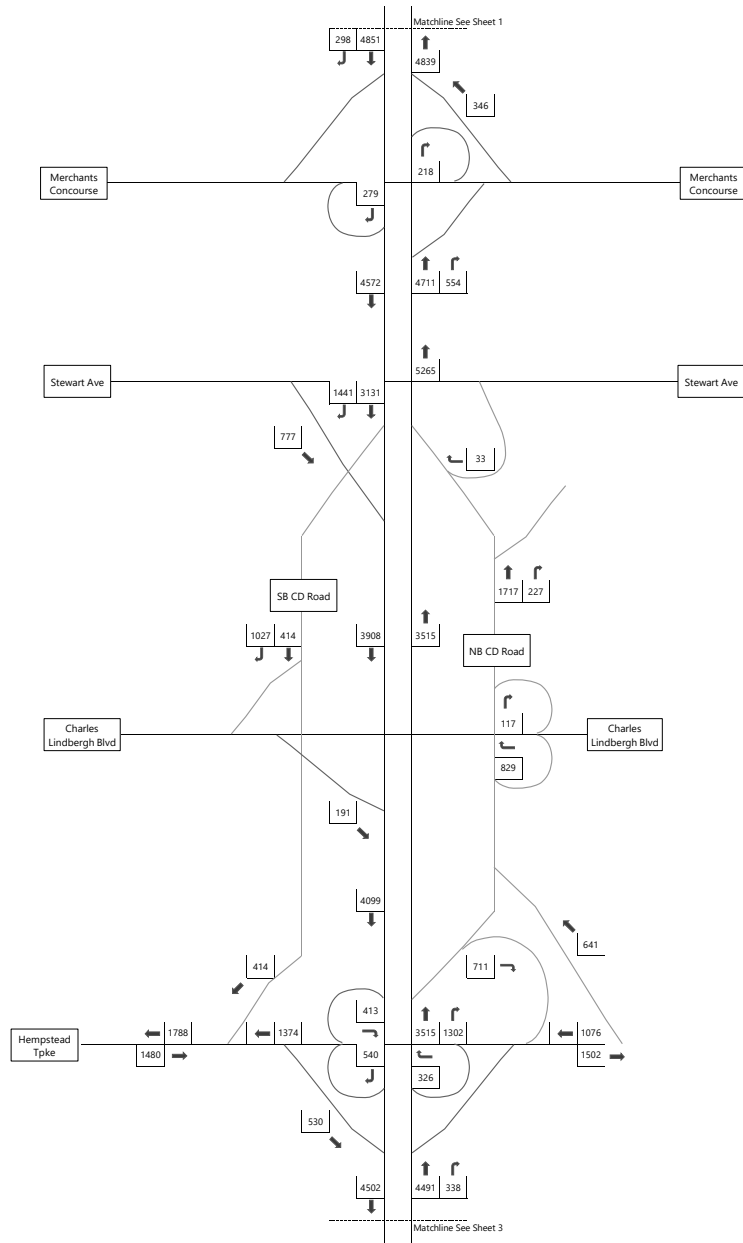

Figure V-E-4, Sheet 2
 2030 Build Parkway Traffic Volumes
 Saturday Midday Peak Hour
 26841.01 - Sands New York Integrated Resort
 Meadowbrook State Parkway



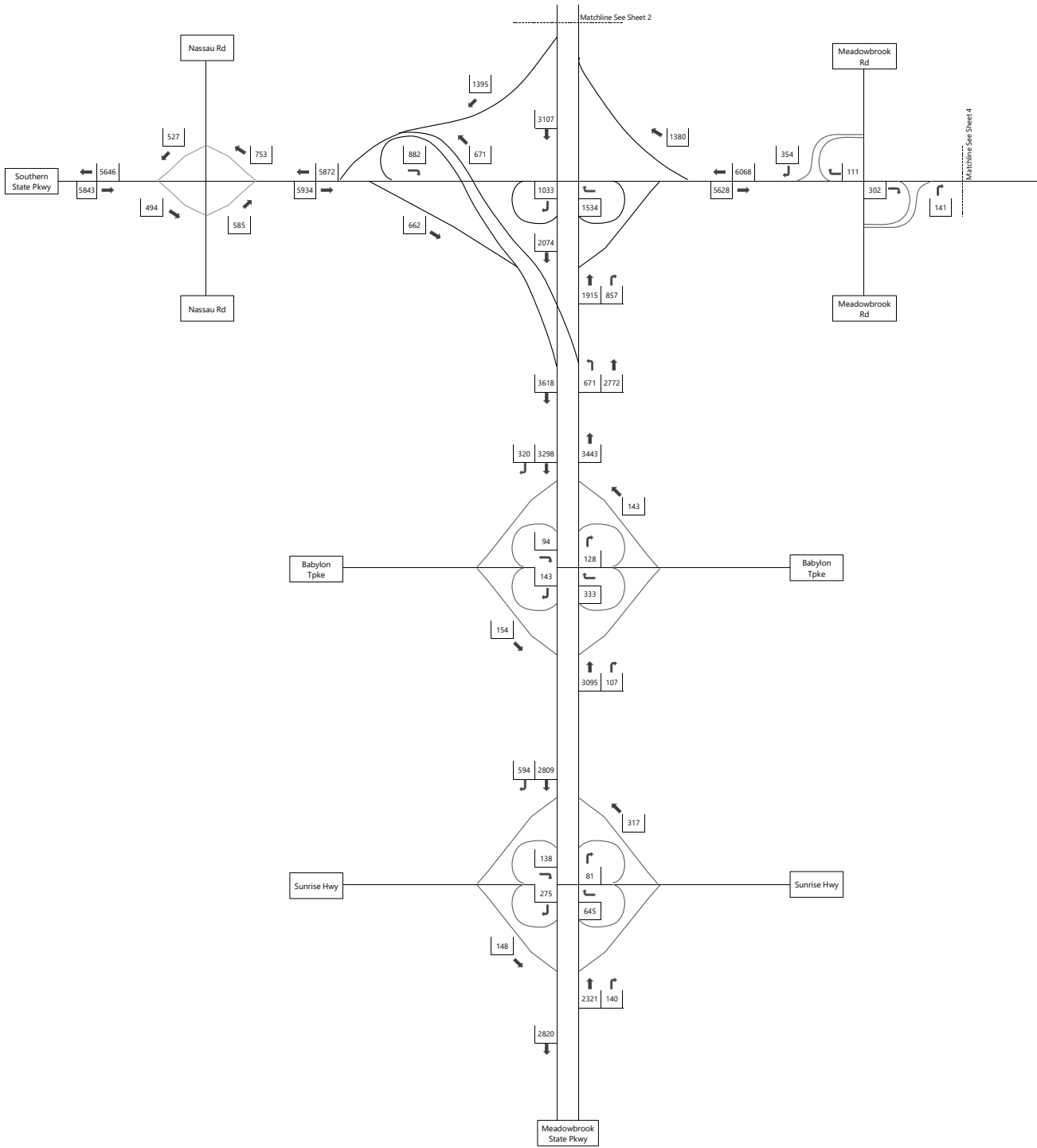

Figure V-E-4, Sheet 3
 2030 Build Parkway Traffic Volumes
 Saturday Midday Peak Hour
 26841.01 - Sands New York Integrated Resort
 Meadowbrook State Parkway



Not to Scale



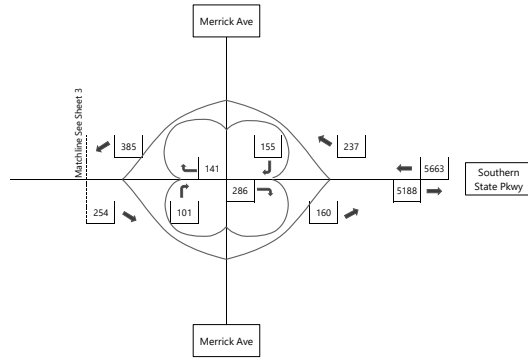
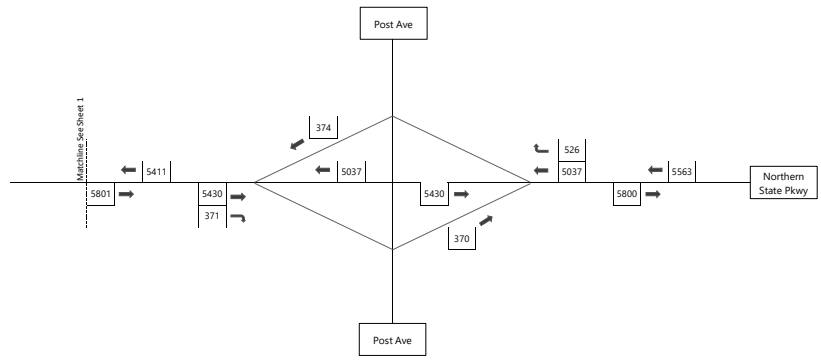

Figure V-E-4, Sheet 4
 2030 Build Parkway Traffic Volumes
 Saturday Midday Peak Hour
 26841.01 - Sands New York Integrated Resort
 Meadowbrook State Parkway



Not to Scale



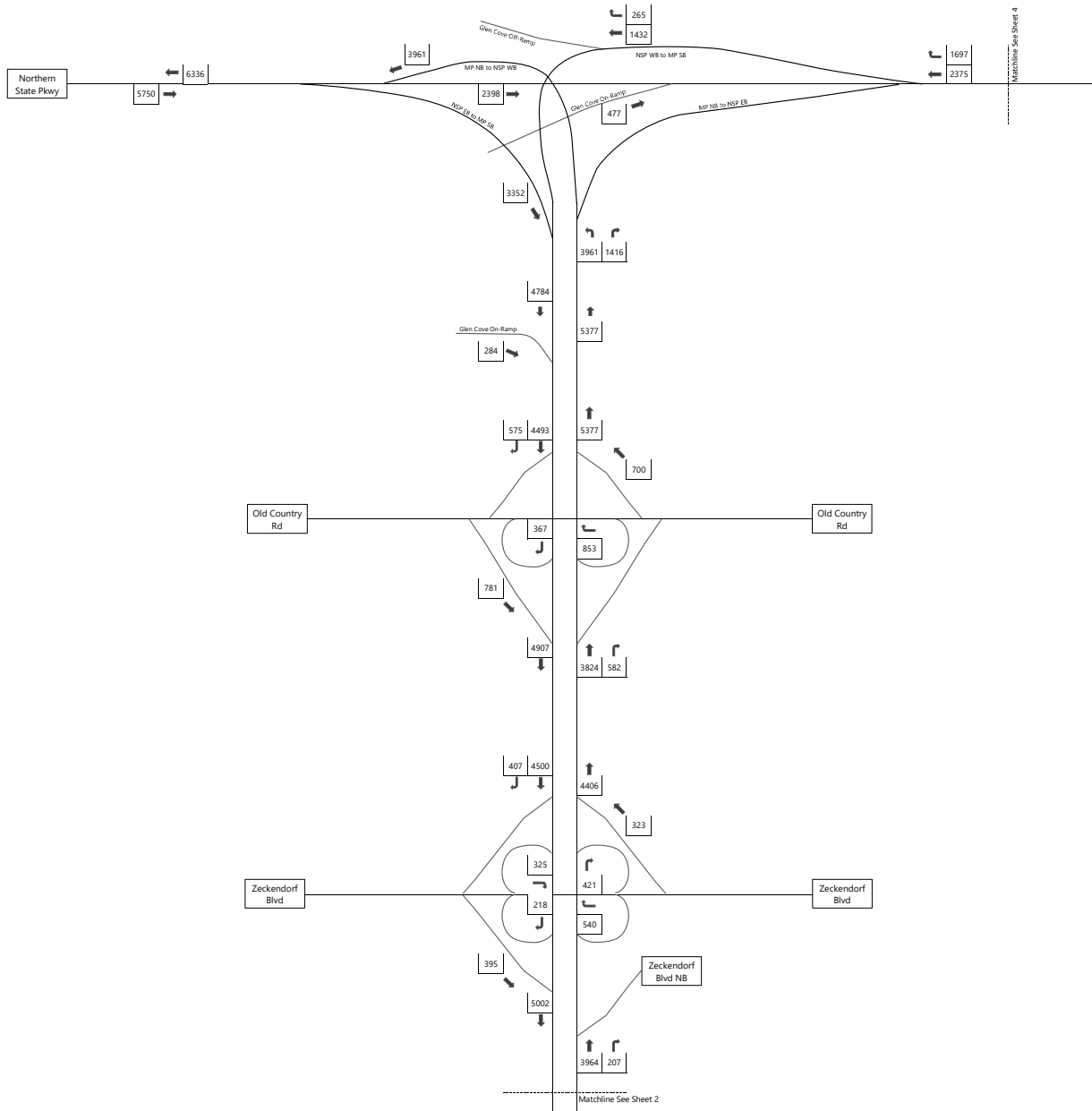

Figure V-E-5, Sheet 1
 2030 Build Parkway Traffic Volumes
 Saturday Evening Peak Hour
 26841.01 - Sands New York Integrated Resort
 Meadowbrook State Parkway



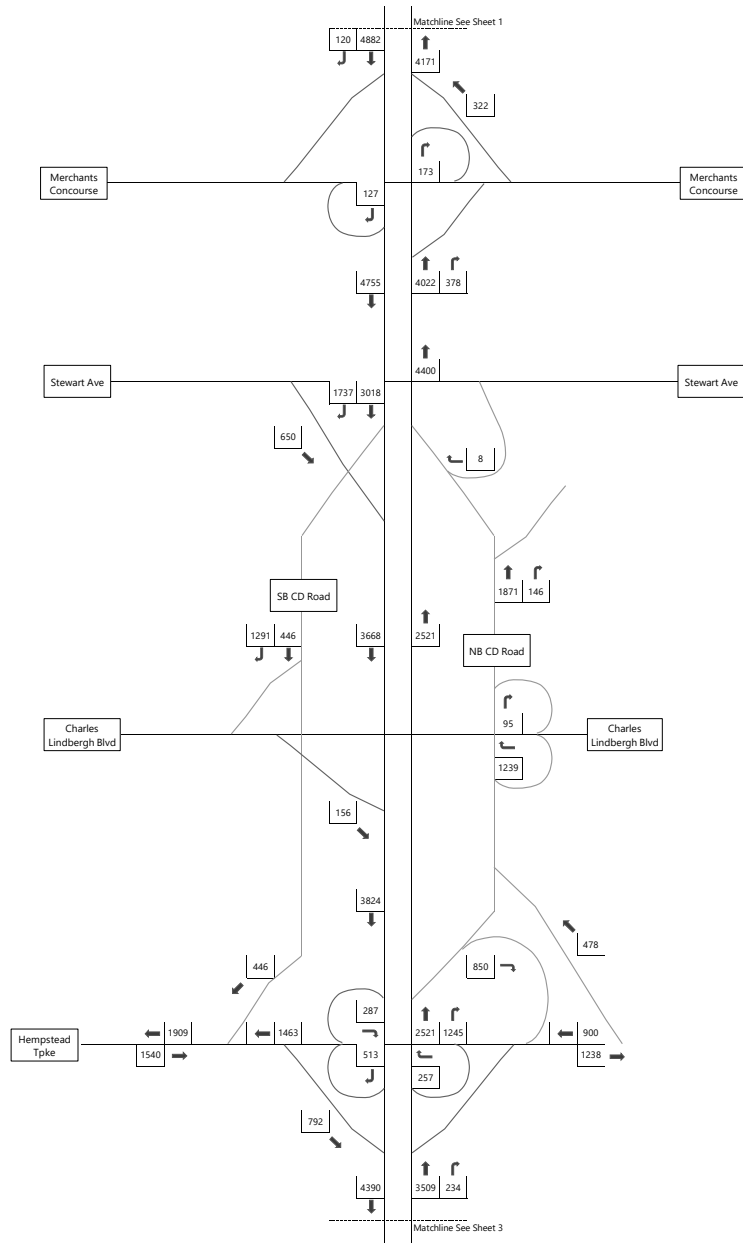

Figure V-E-5, Sheet 2
 2030 Build Parkway Traffic Volumes
 Saturday Evening Peak Hour
 26841.01 - Sands New York Integrated Resort
 Meadowbrook State Parkway



Not to Scale



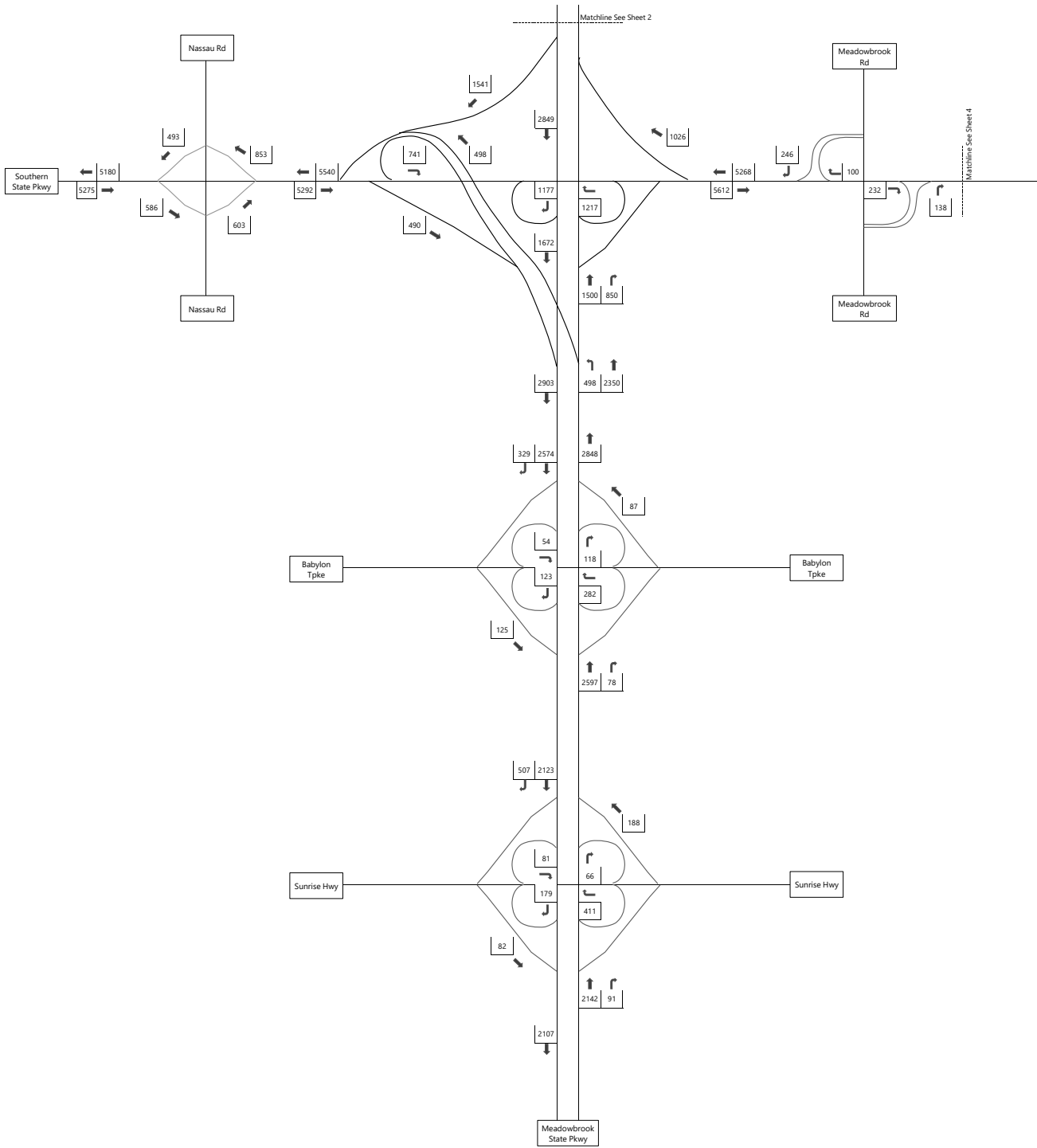

Figure V-E-5, Sheet 3
 2030 Build Parkway Traffic Volumes
 Saturday Evening Peak Hour
 26841.01 - Sands New York Integrated Resort
 Meadowbrook State Parkway



Not to Scale



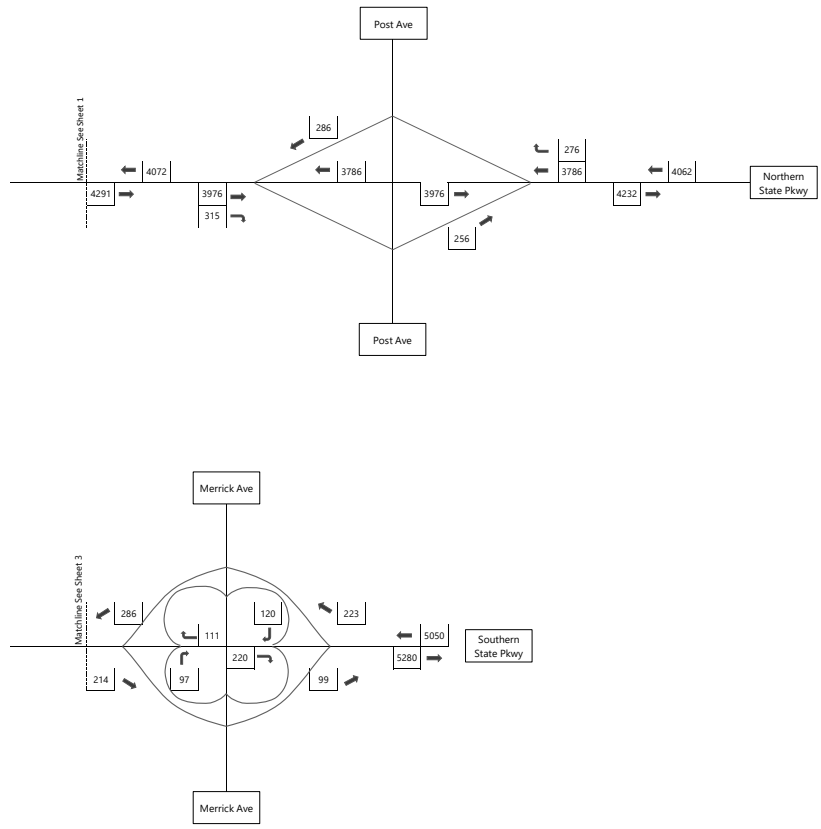

Figure V-E-5, Sheet 4
 2030 Build Parkway Traffic Volumes
 Saturday Evening Peak Hour
 26841.01 - Sands New York Integrated Resort
 Meadowbrook State Parkway



Not to Scale



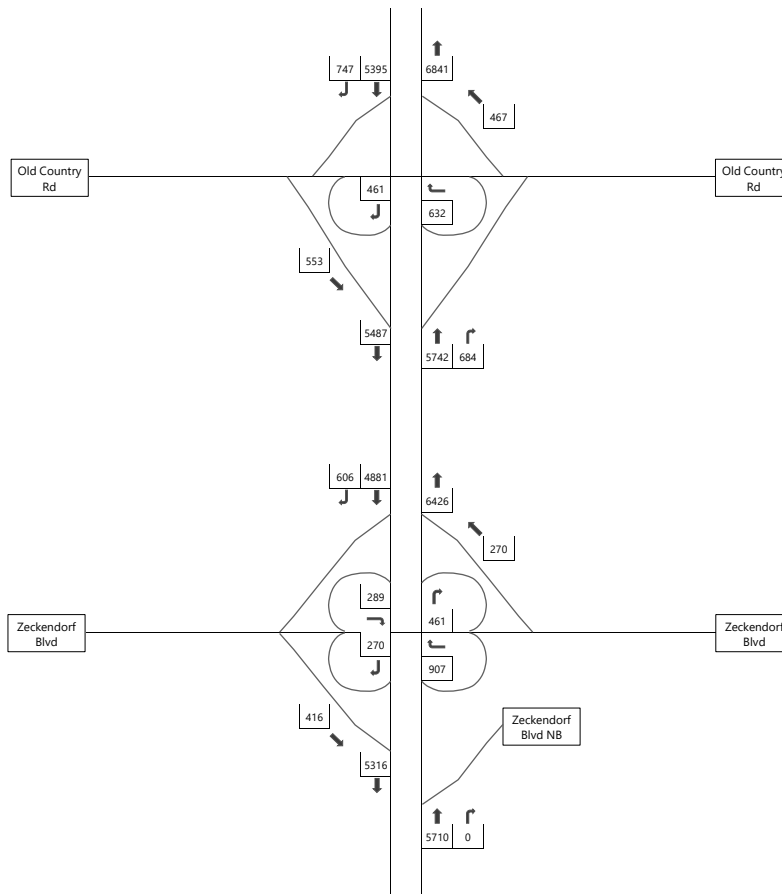

Figure V-E-6, Sheet 1
 2030 Build Parkway Traffic Volumes
 Weekday PM Peak Hour - Holiday
 26841.01 - Sands New York Integrated Resort
 Meadowbrook State Parkway



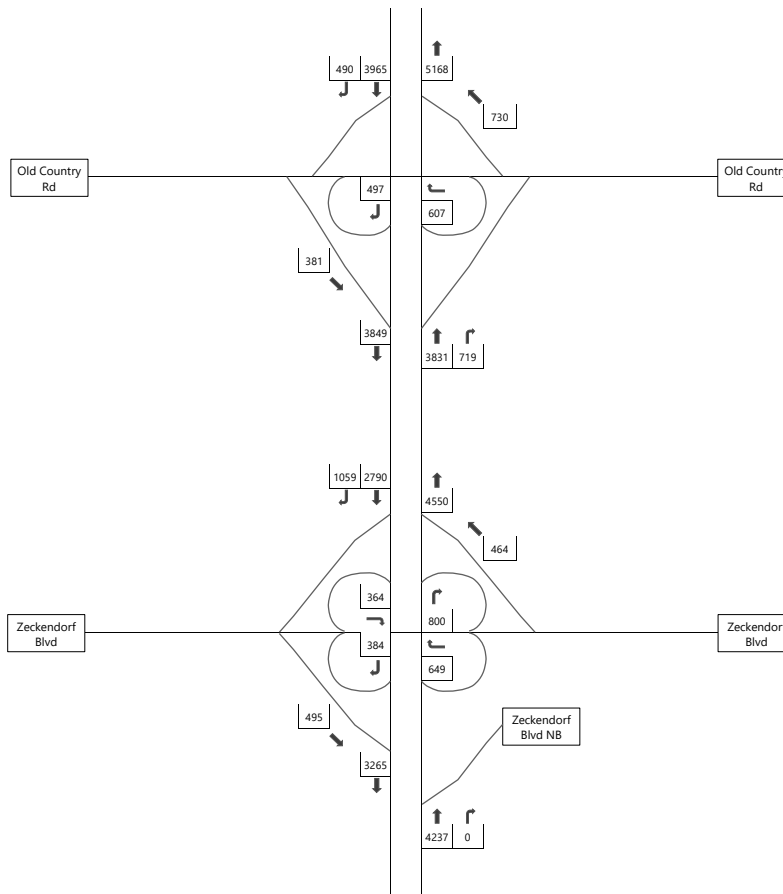

Figure V-C-6, Sheet 1
 2030 Build Parkway Traffic Volumes
 Saturday Midday Peak Hour - Holiday
 26841.01 - Sands New York Integrated Resort
 Meadowbrook State Parkway





2027 Phase 1

V-C 2027 No-Build Traffic Volumes

**26841.01: Sands Integrated Resort
Traffic Impact Study Attachments
Attachment F – Parkway Peak Hour Traffic Volume Figures**



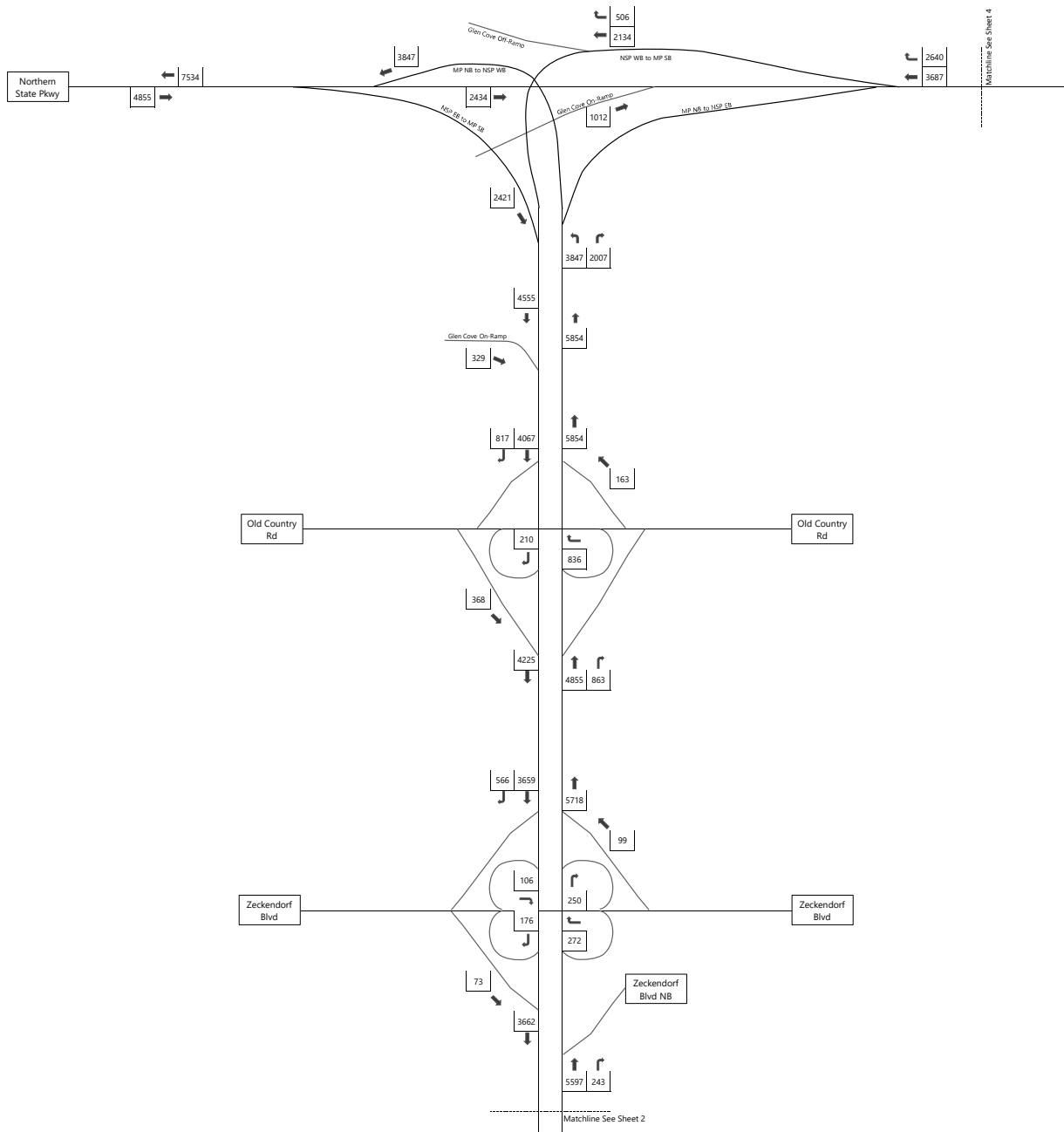

Figure V-C-8, Sheet 1
 2027 No-Build Parkway Traffic Volumes
 Weekday AM Peak Hour
 26841.01 - Sands New York Integrated Resort
 Meadowbrook State Parkway



Not to Scale



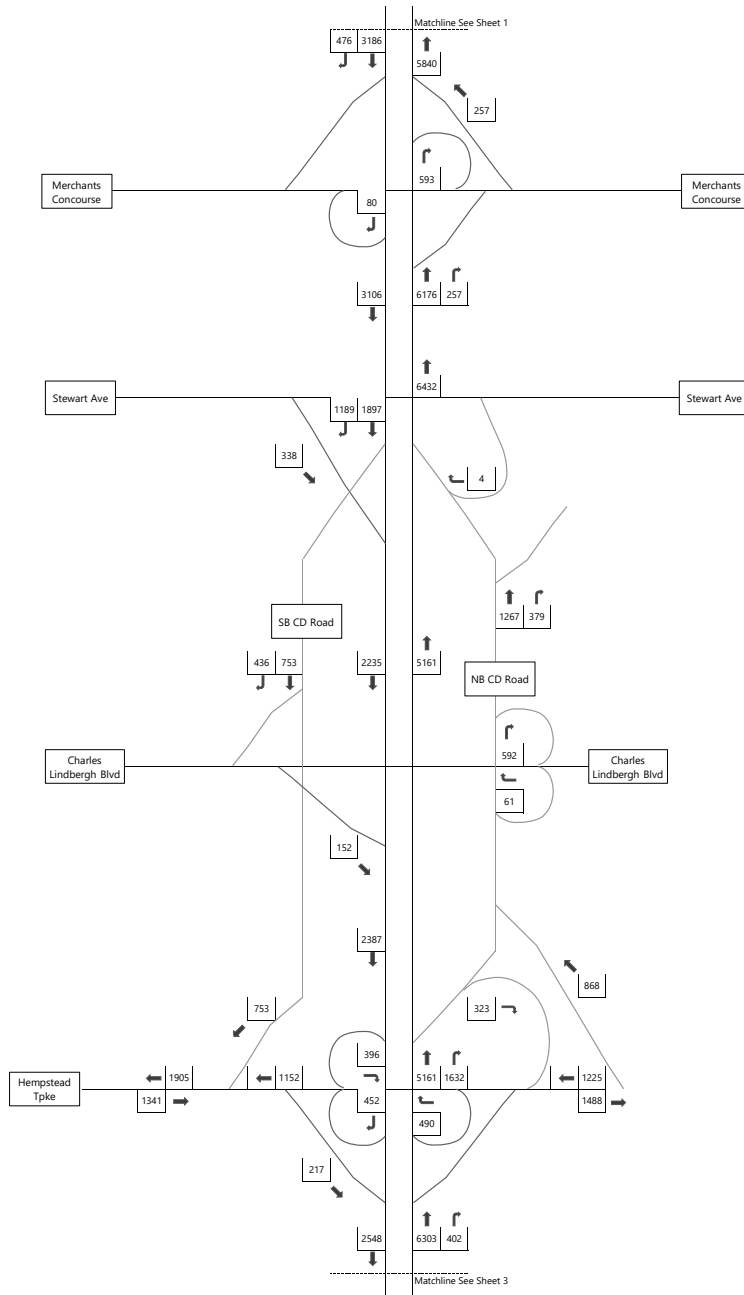

Figure V-C-8, Sheet 2
 2027 No-Build Parkway Traffic Volumes
 Weekday AM Peak Hour
 26841.01 - Sands New York Integrated Resort
 Meadowbrook State Parkway



Not to Scale



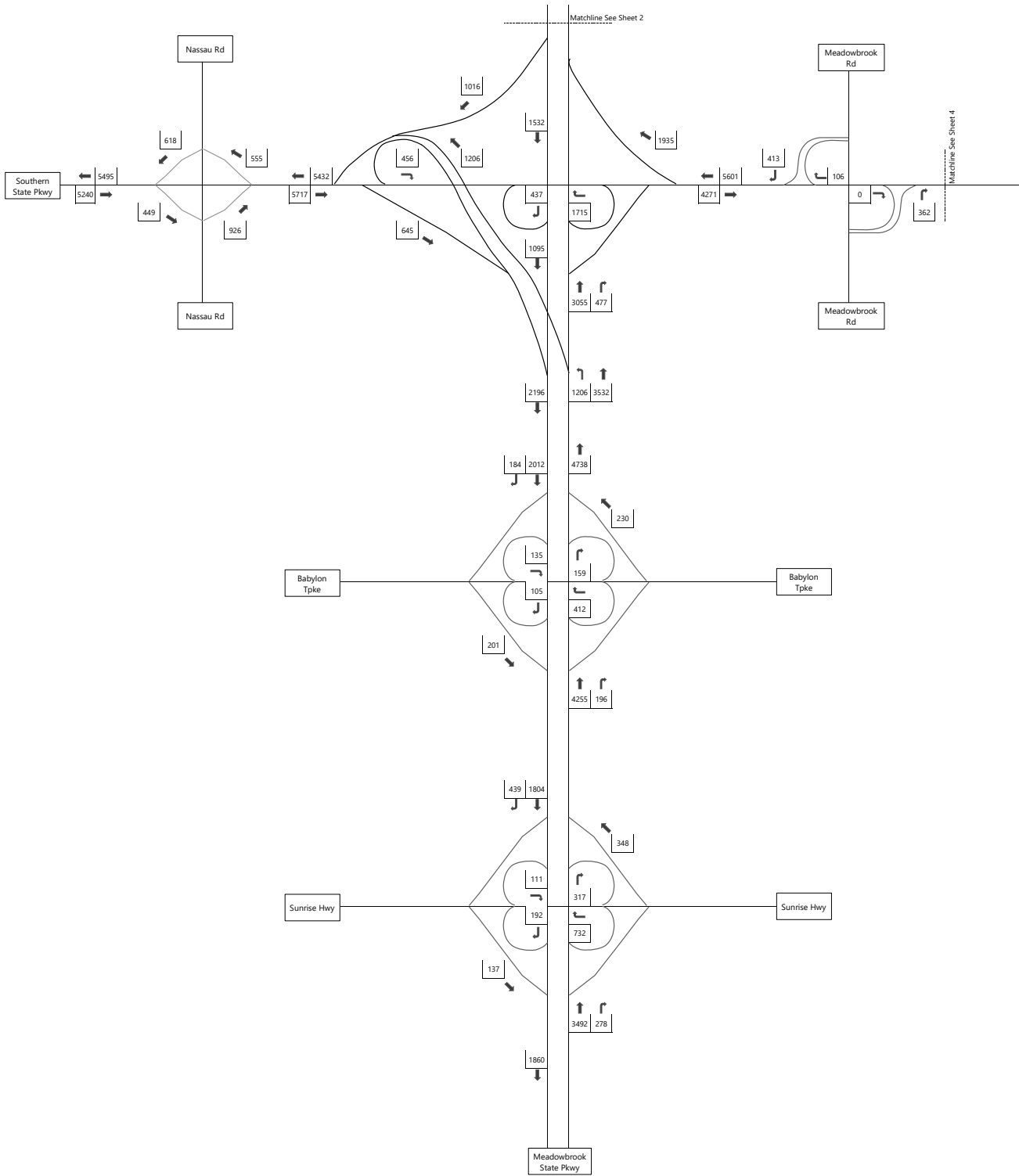

Figure V-C-8, Sheet 3
 2027 No-Build Parkway Traffic Volumes
 Weekday AM Peak Hour
 26841.01 - Sands New York Integrated Resort
 Meadowbrook State Parkway



Not to Scale



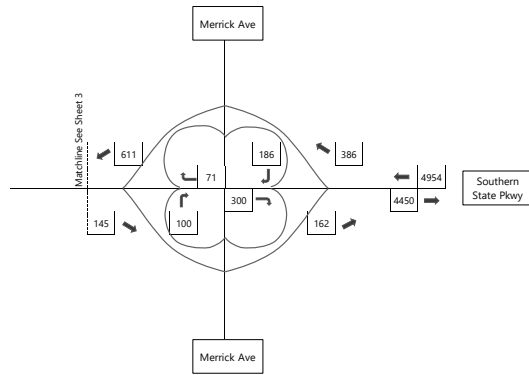
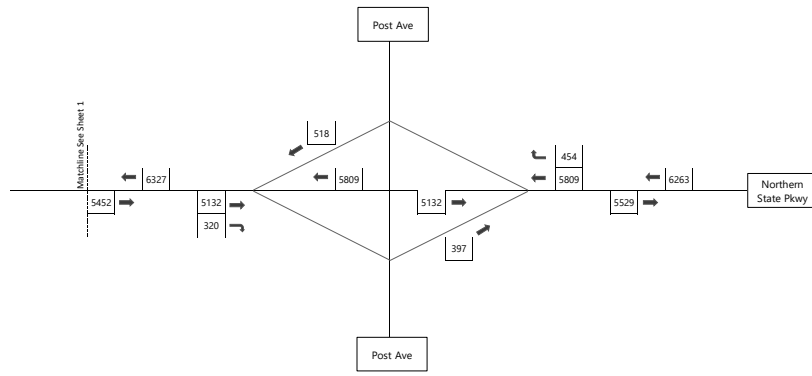

Figure V-C-8, Sheet 4
 2027 No-Build Parkway Traffic Volumes
 Weekday AM Peak Hour
 26841.01 - Sands New York Integrated Resort
 Meadowbrook State Parkway



Not to Scale



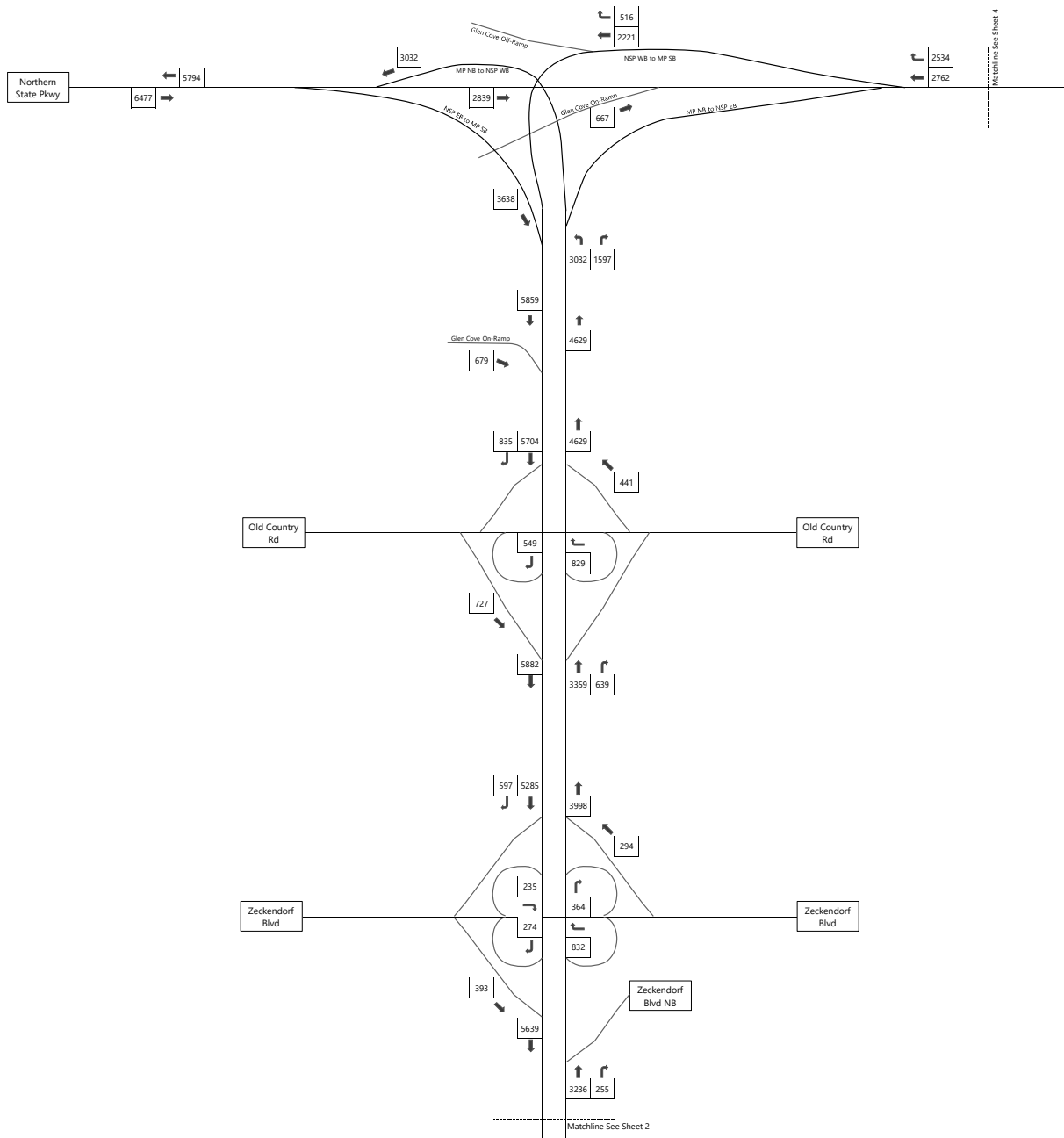

Figure V-C-9, Sheet 1
 2027 No-Build Parkway Traffic Volumes
 Weekday PM Peak Hour
 26841.01 - Sands New York Integrated Resort
 Meadowbrook State Parkway



Not to Scale



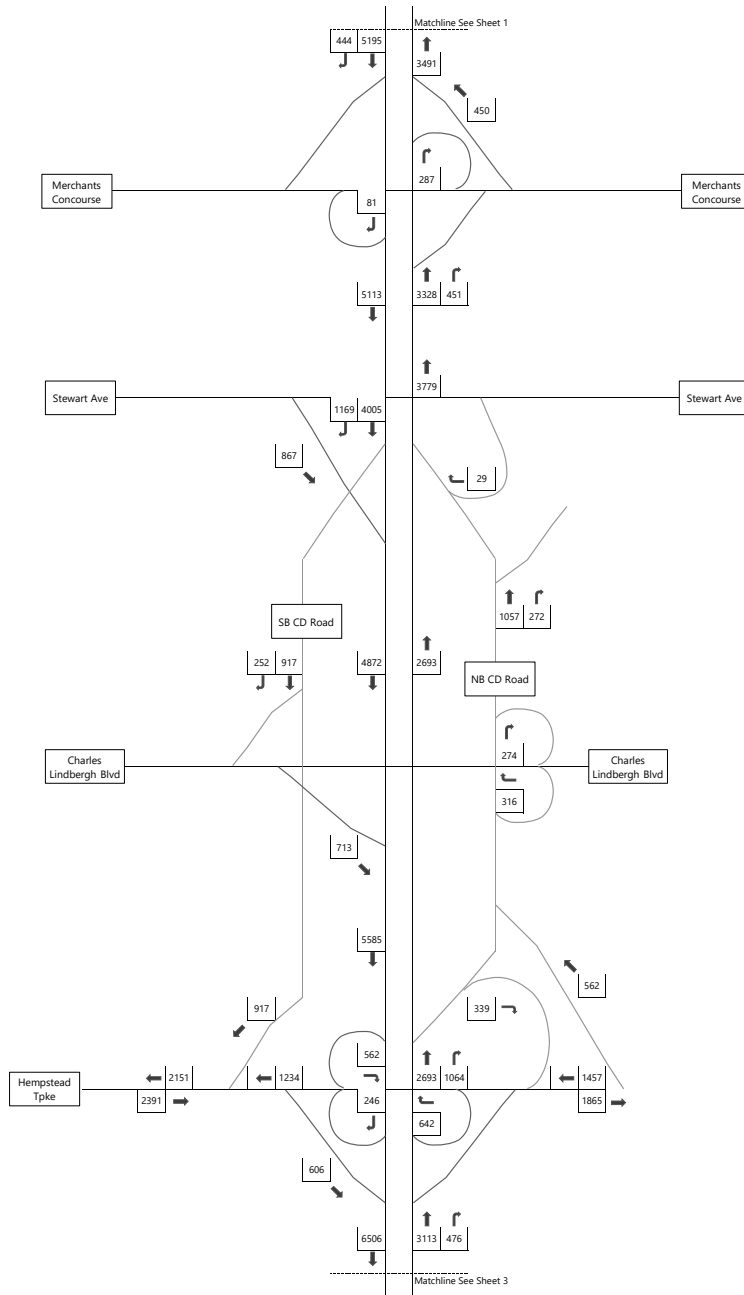

Figure V-C-9, Sheet 2
 2027 No-Build Parkway Traffic Volumes
 Weekday PM Peak Hour
 26841.01 - Sands New York Integrated Resort
 Meadowbrook State Parkway



Not to Scale



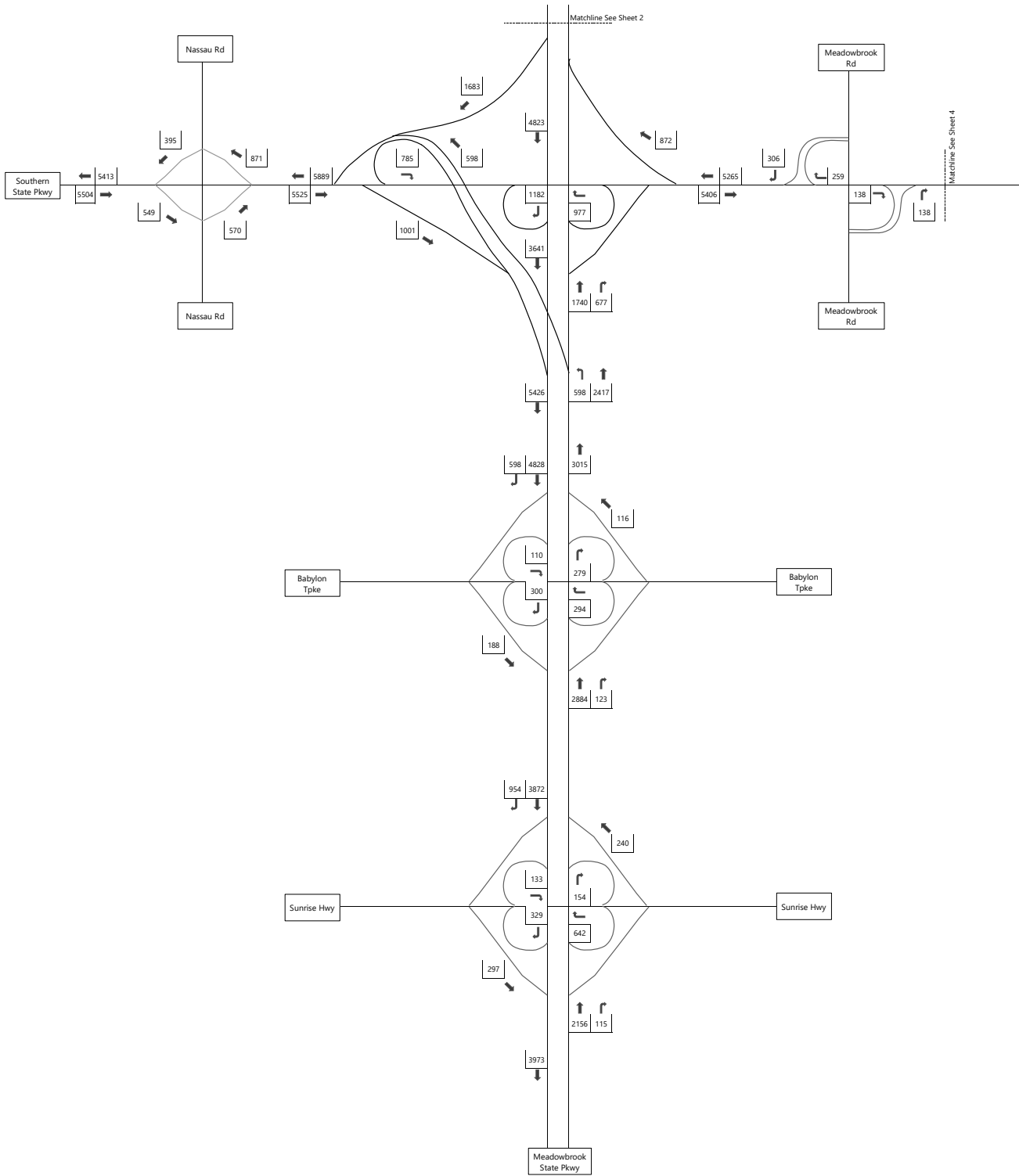

Figure V-C-9, Sheet 3
 2027 No-Build Parkway Traffic Volumes
 Weekday PM Peak Hour
 26841.01 - Sands New York Integrated Resort
 Meadowbrook State Parkway



Not to Scale



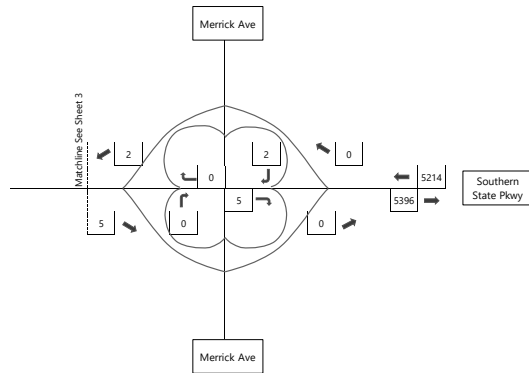
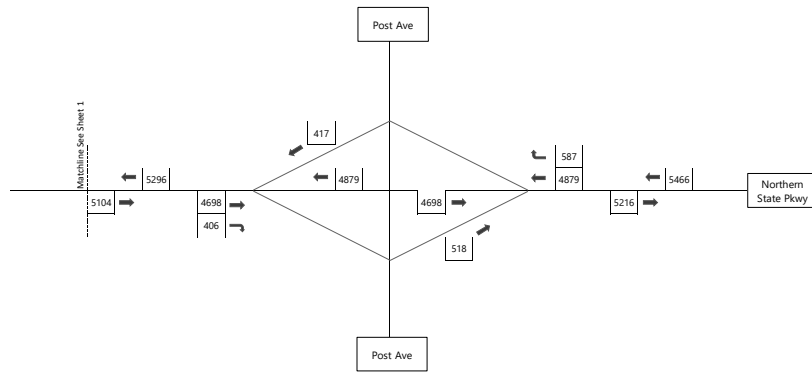

Figure V-C-9, Sheet 4
 2027 No-Build Parkway Traffic Volumes
 Weekday PM Peak Hour
 26841.01 - Sands New York Integrated Resort
 Meadowbrook State Parkway



Not to Scale



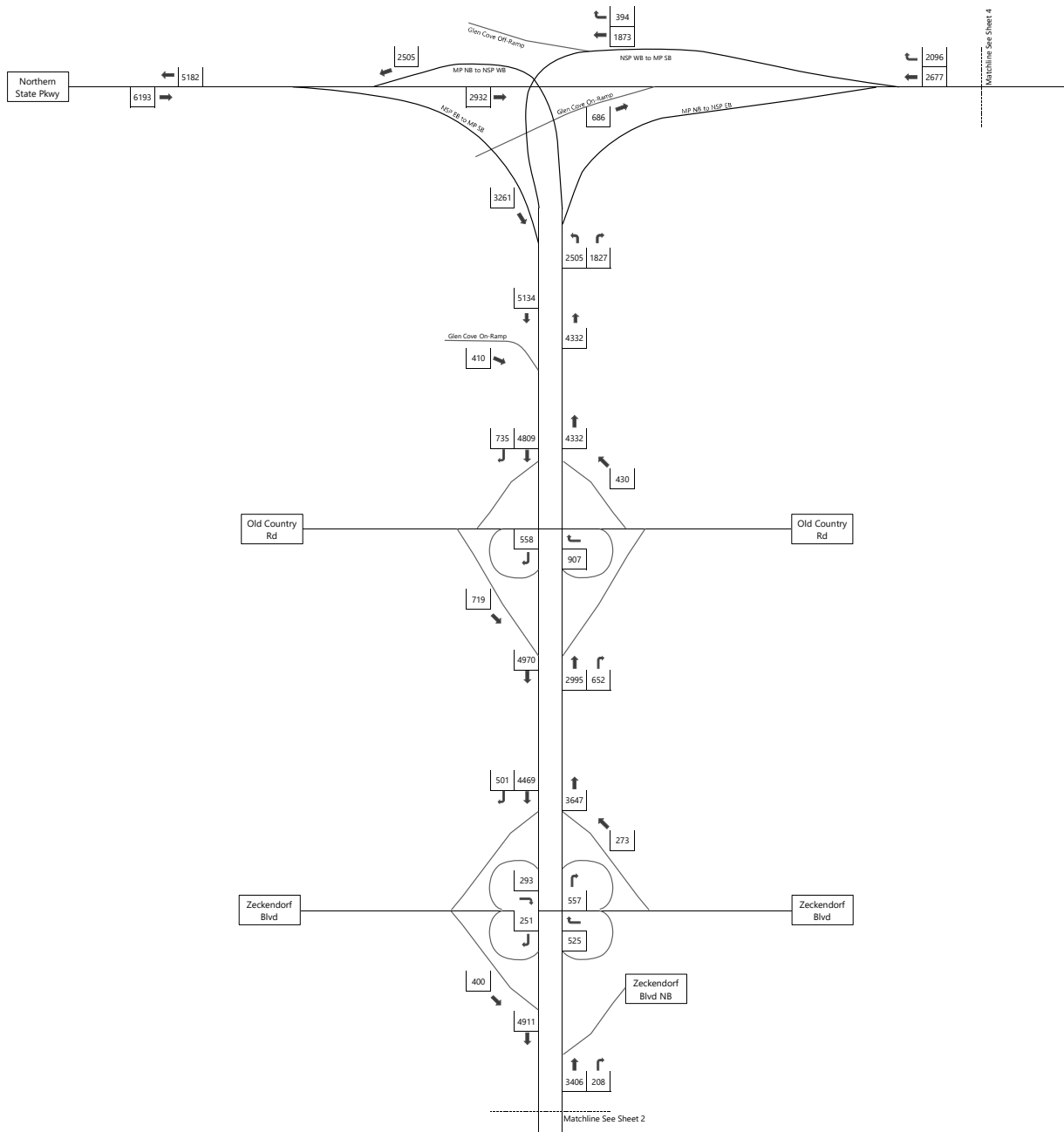

Figure V-C-10, Sheet 1
 2027 No-Build Parkway Traffic Volumes
 Friday Evening Peak Hour
 26841.01 - Sands New York Integrated Resort
 Meadowbrook State Parkway



Not to Scale



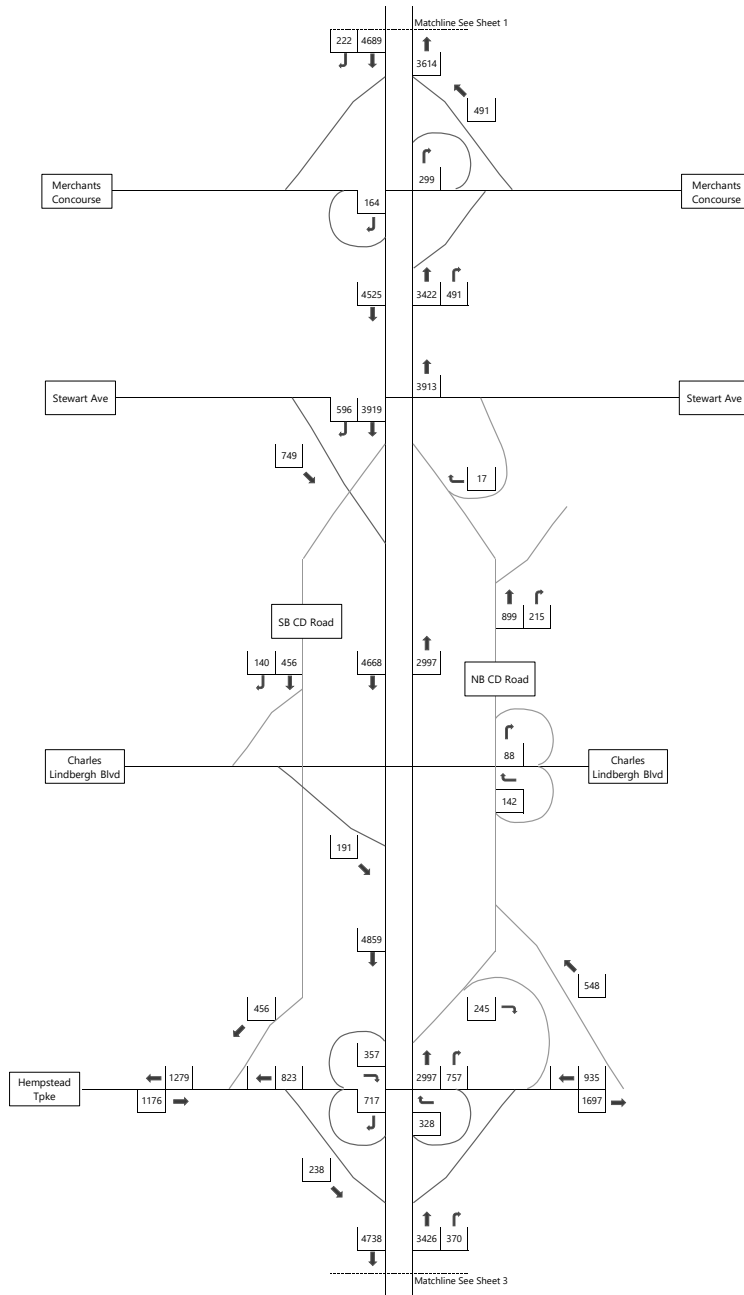

Figure V-C-10, Sheet 2
 2027 No-Build Parkway Traffic Volumes
 Friday Evening Peak Hour
 26841.01 - Sands New York Integrated Resort
 Meadowbrook State Parkway



Not to Scale



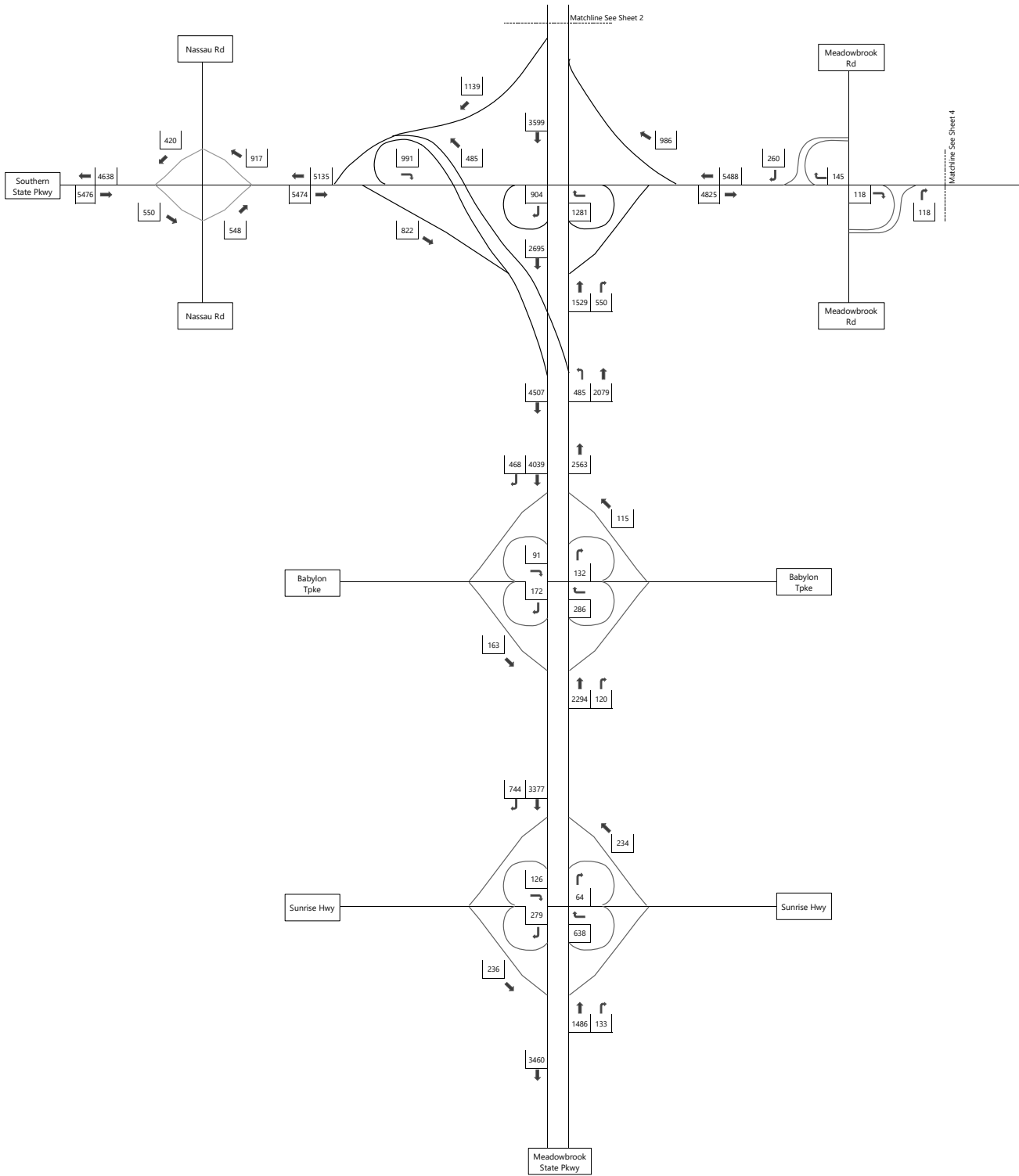

Figure V-C-10, Sheet 3
 2027 No-Build Parkway Traffic Volumes
 Friday Evening Peak Hour
 26841.01 - Sands New York Integrated Resort
 Meadowbrook State Parkway



Not to Scale



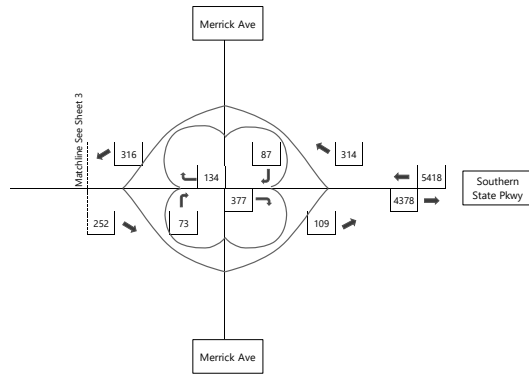
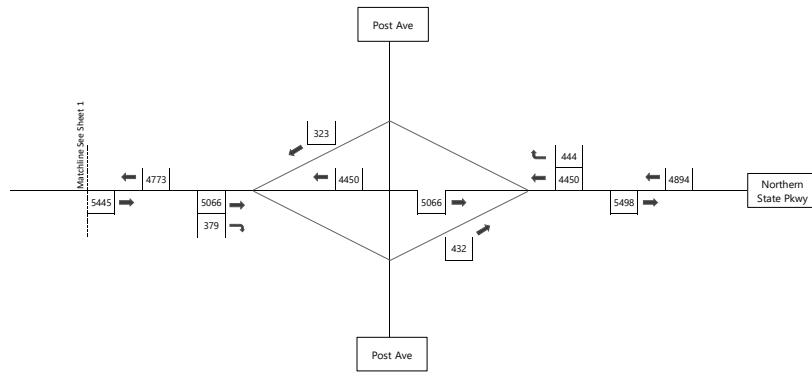

Figure V-C-10, Sheet 4
 2027 No-Build Parkway Traffic Volumes
 Friday Evening Peak Hour
 26841.01 - Sands New York Integrated Resort
 Meadowbrook State Parkway



Not to Scale



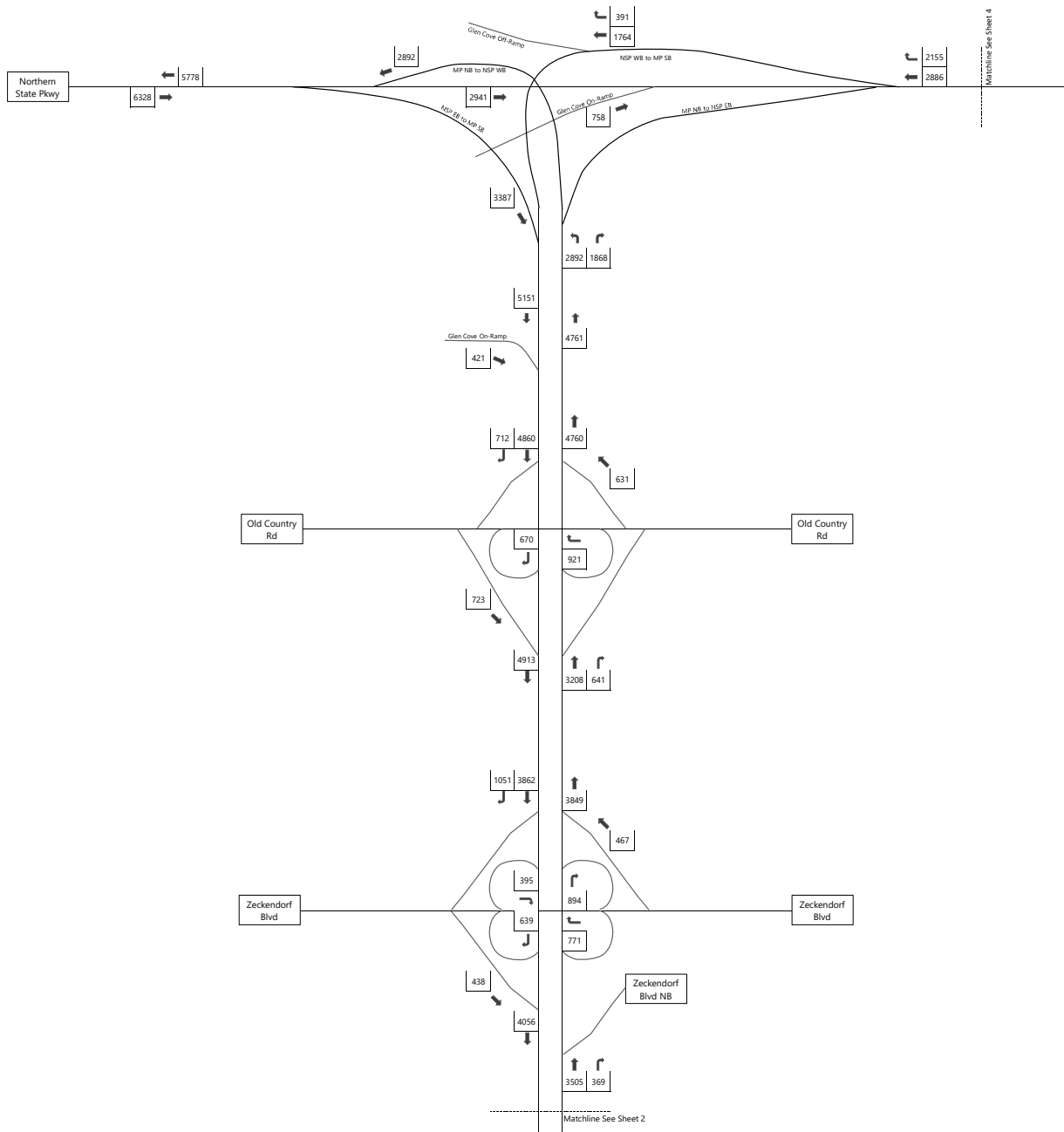

Figure V-C-11, Sheet 1
 2027 No-Build Parkway Traffic Volumes
 Saturday Midday Peak Hour
 26841.01 - Sands New York Integrated Resort
 Meadowbrook State Parkway



Not to Scale



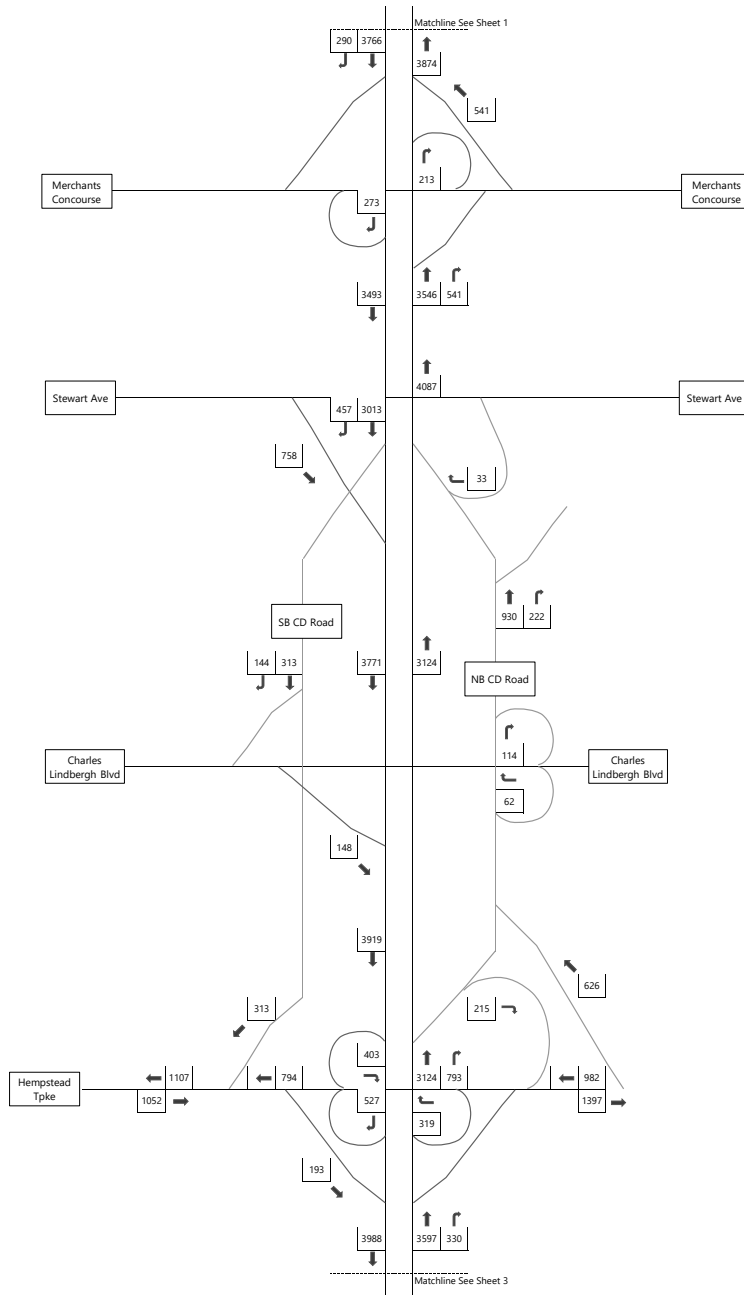

Figure V-C-11, Sheet 2
 2027 No-Build Parkway Traffic Volumes
 Saturday Midday Peak Hour
 26841.01 - Sands New York Integrated Resort
 Meadowbrook State Parkway



Not to Scale



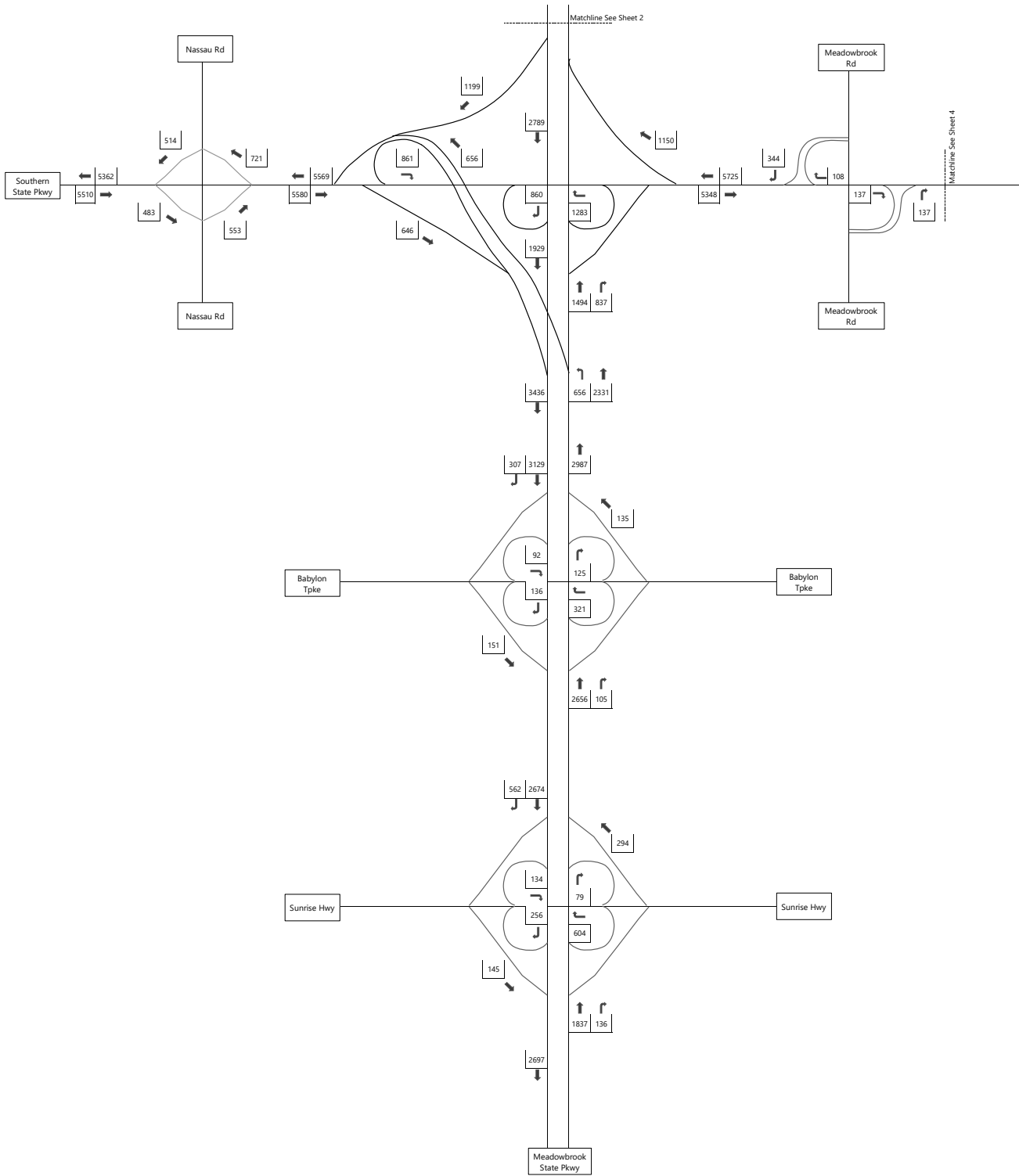

Figure V-C-11, Sheet 3
 2027 No-Build Parkway Traffic Volumes
 Saturday Midday Peak Hour
 26841.01 - Sands New York Integrated Resort
 Meadowbrook State Parkway



Not to Scale



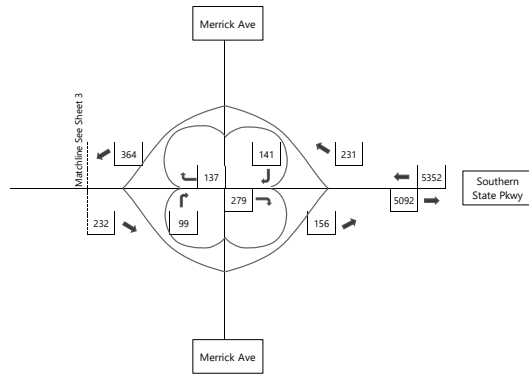
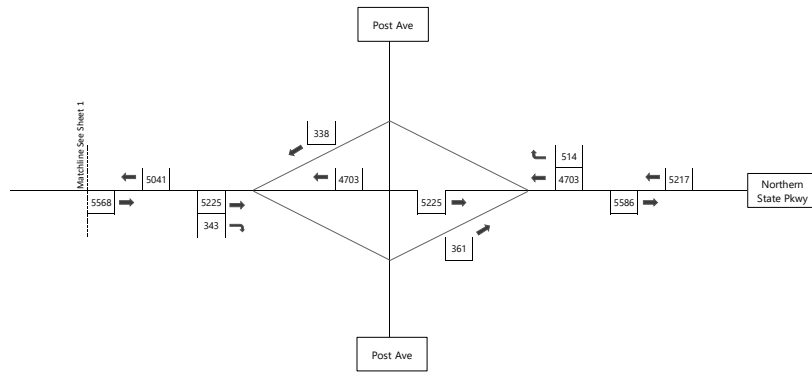

Figure V-C-11, Sheet 4
 2027 No-Build Parkway Traffic Volumes
 Saturday Midday Peak Hour
 26841.01 - Sands New York Integrated Resort
 Meadowbrook State Parkway



Not to Scale



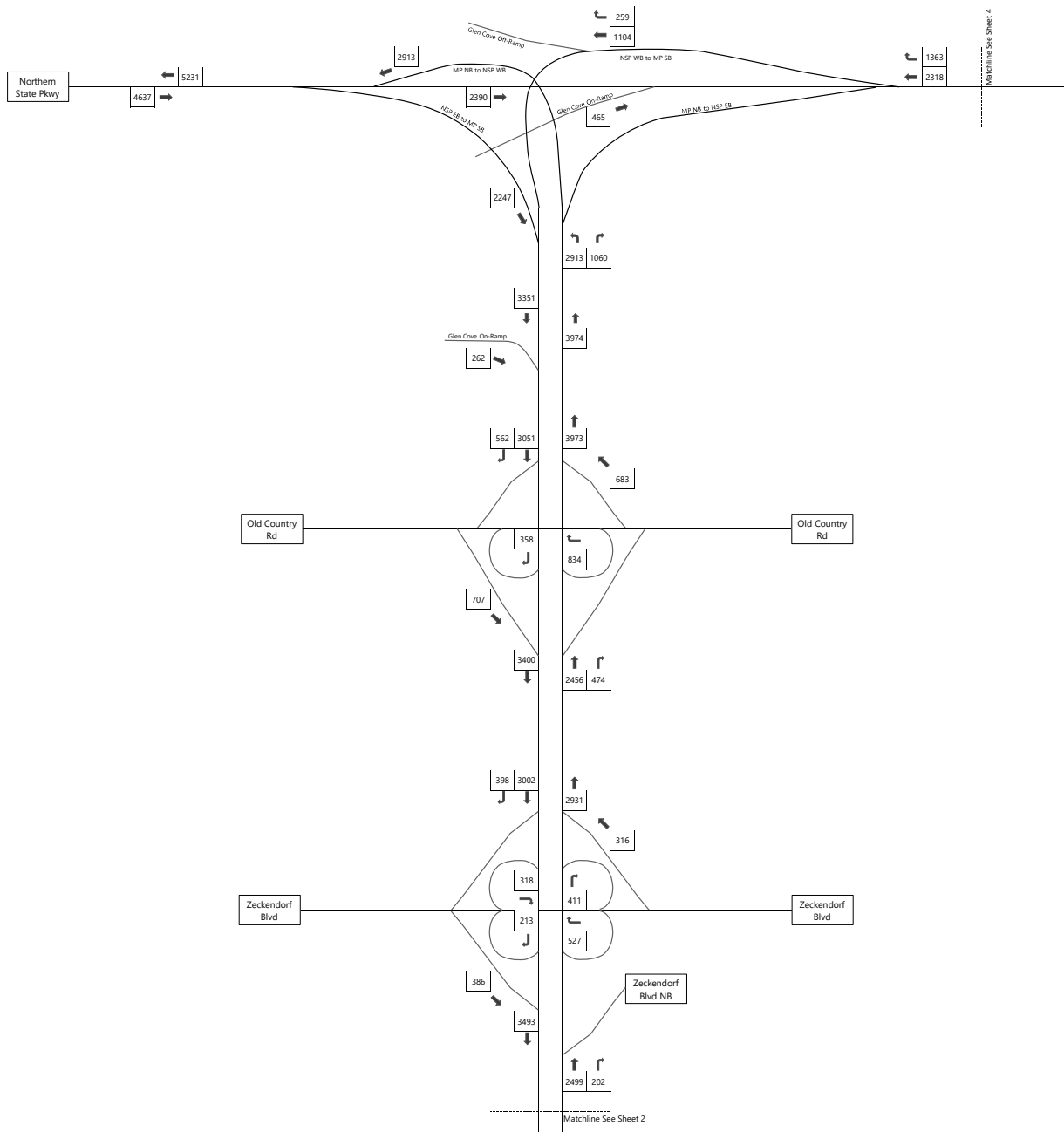

Figure V-C-12, Sheet 1
 2027 No-Build Parkway Traffic Volumes
 Saturday Evening Peak Hour
 26841.01 - Sands New York Integrated Resort
 Meadowbrook State Parkway



Not to Scale



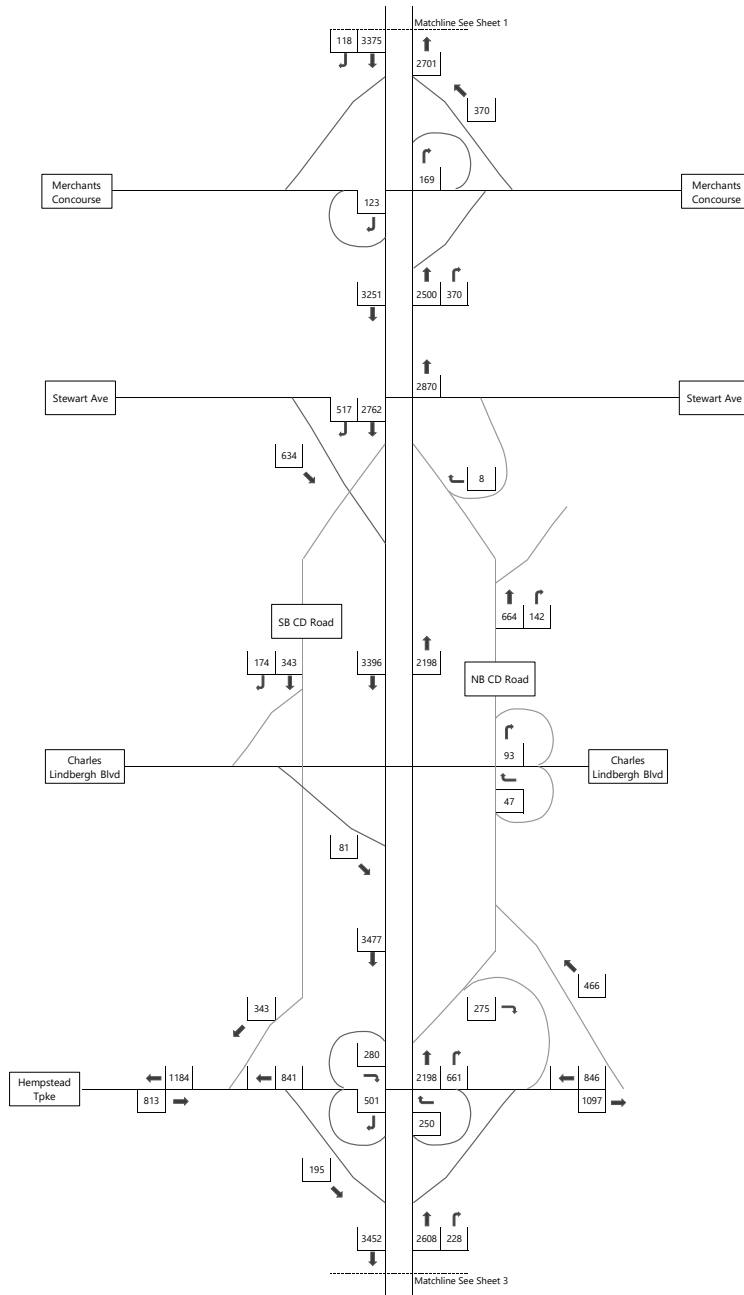

Figure V-C-12, Sheet 2
 2027 No-Build Parkway Traffic Volumes
 Saturday Evening Peak Hour
 26841.01 - Sands New York Integrated Resort
 Meadowbrook State Parkway



Not to Scale



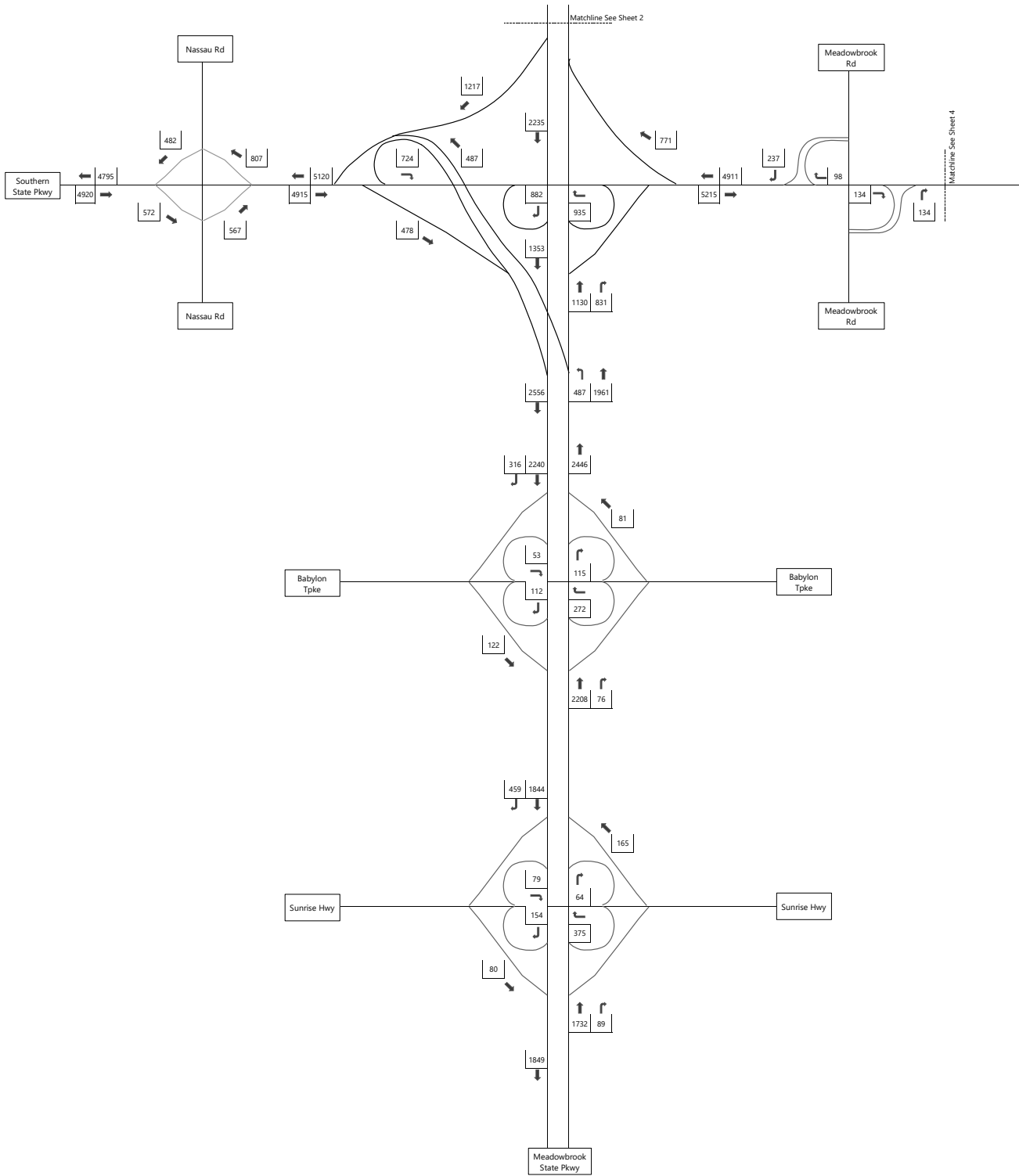

Figure V-C-12, Sheet 3
 2027 No-Build Parkway Traffic Volumes
 Saturday Evening Peak Hour
 26841.01 - Sands New York Integrated Resort
 Meadowbrook State Parkway



Not to Scale



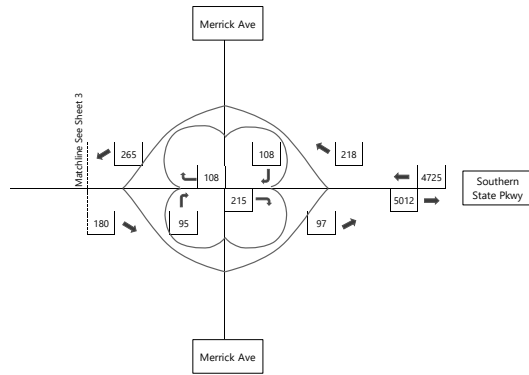
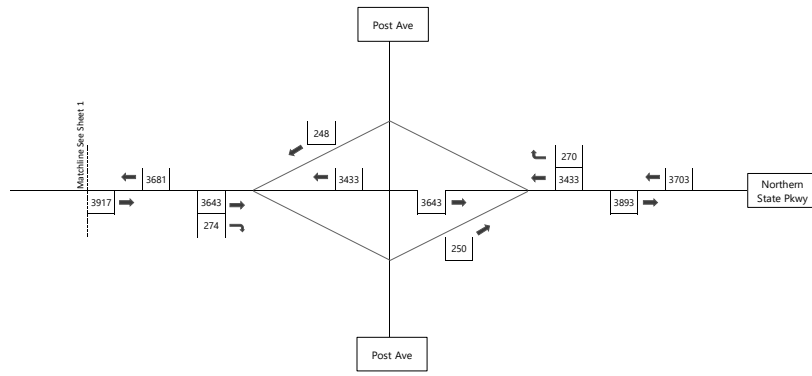

Figure V-C-12, Sheet 4
 2027 No-Build Parkway Traffic Volumes
 Saturday Evening Peak Hour
 26841.01 - Sands New York Integrated Resort
 Meadowbrook State Parkway



Not to Scale



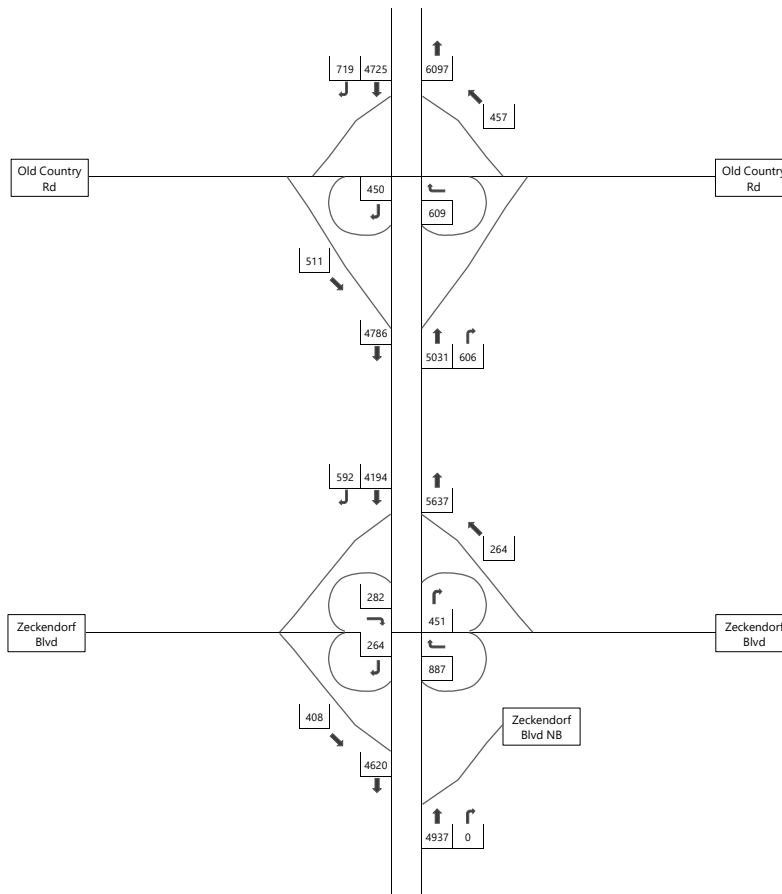

Figure V-C-13, Sheet 1
 2027 No-Build Parkway Traffic Volumes
 Weekday PM Peak Hour - Holiday
 26841.01 - Sands New York Integrated Resort
 Meadowbrook State Parkway



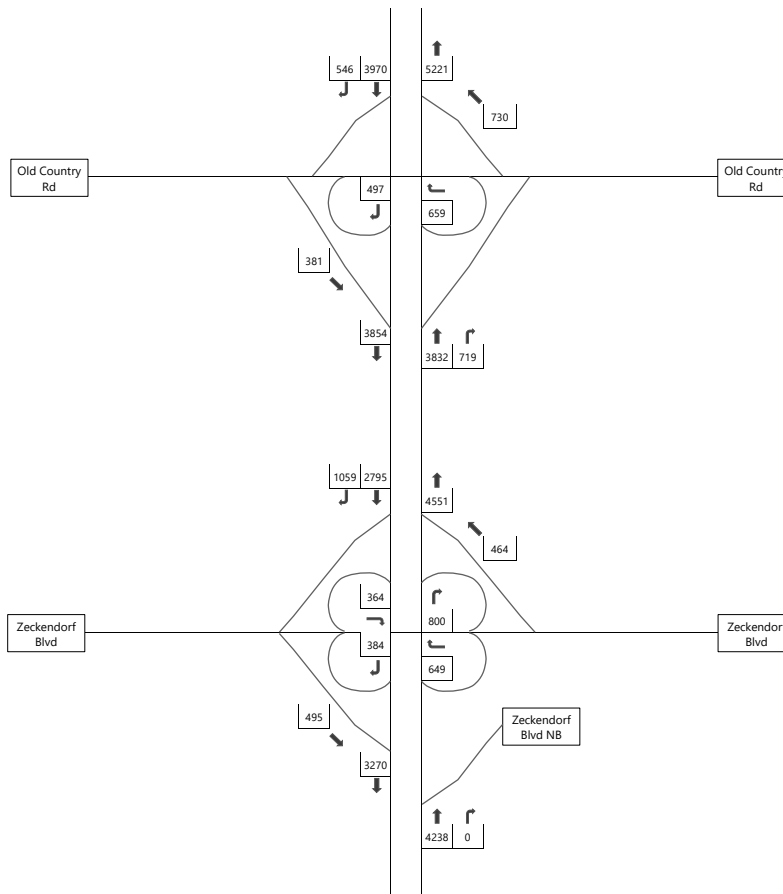

Figure V-C-14, Sheet 1
 2027 No-Build Parkway Traffic Volumes
 Saturday Midday Peak Hour - Holiday
 26841.01 - Sands New York Integrated Resort
 Meadowbrook State Parkway





2027 Phase 1

V-E 2027 Build Traffic Volumes

**26841.01: Sands Integrated Resort
Traffic Impact Study Attachments
Attachment F – Parkway Peak Hour Traffic Volume Figures**



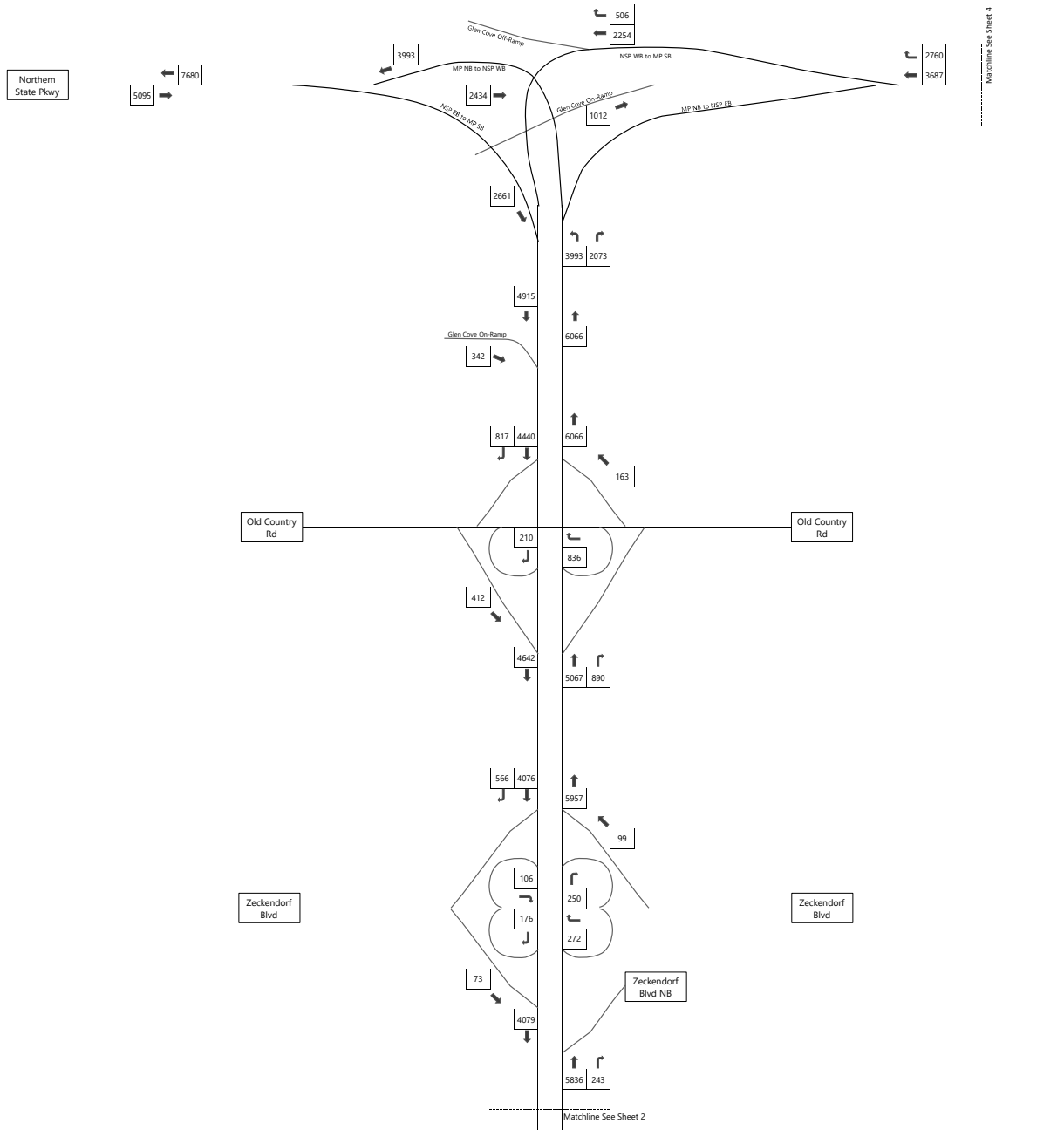

Figure V-E-8, Sheet 1
 2027 Build Parkway Traffic Volumes Weekday
 AM Peak Hour
 26841.01 - Sands New York Integrated Resort
 Meadowbrook State Parkway



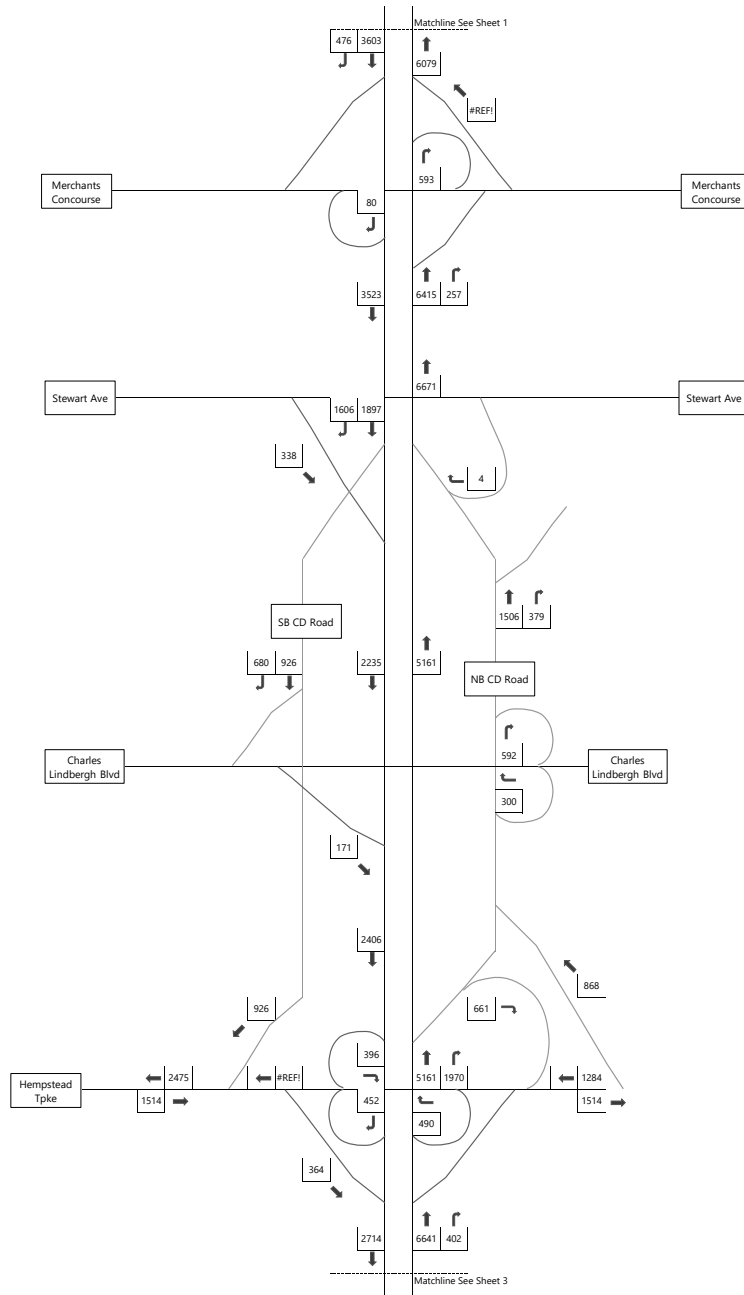

Figure V-E-8, Sheet 2
 2027 Build Parkway Traffic Volumes Weekday
 AM Peak Hour
 26841.01 - Sands New York Integrated Resort
 Meadowbrook State Parkway



Not to Scale



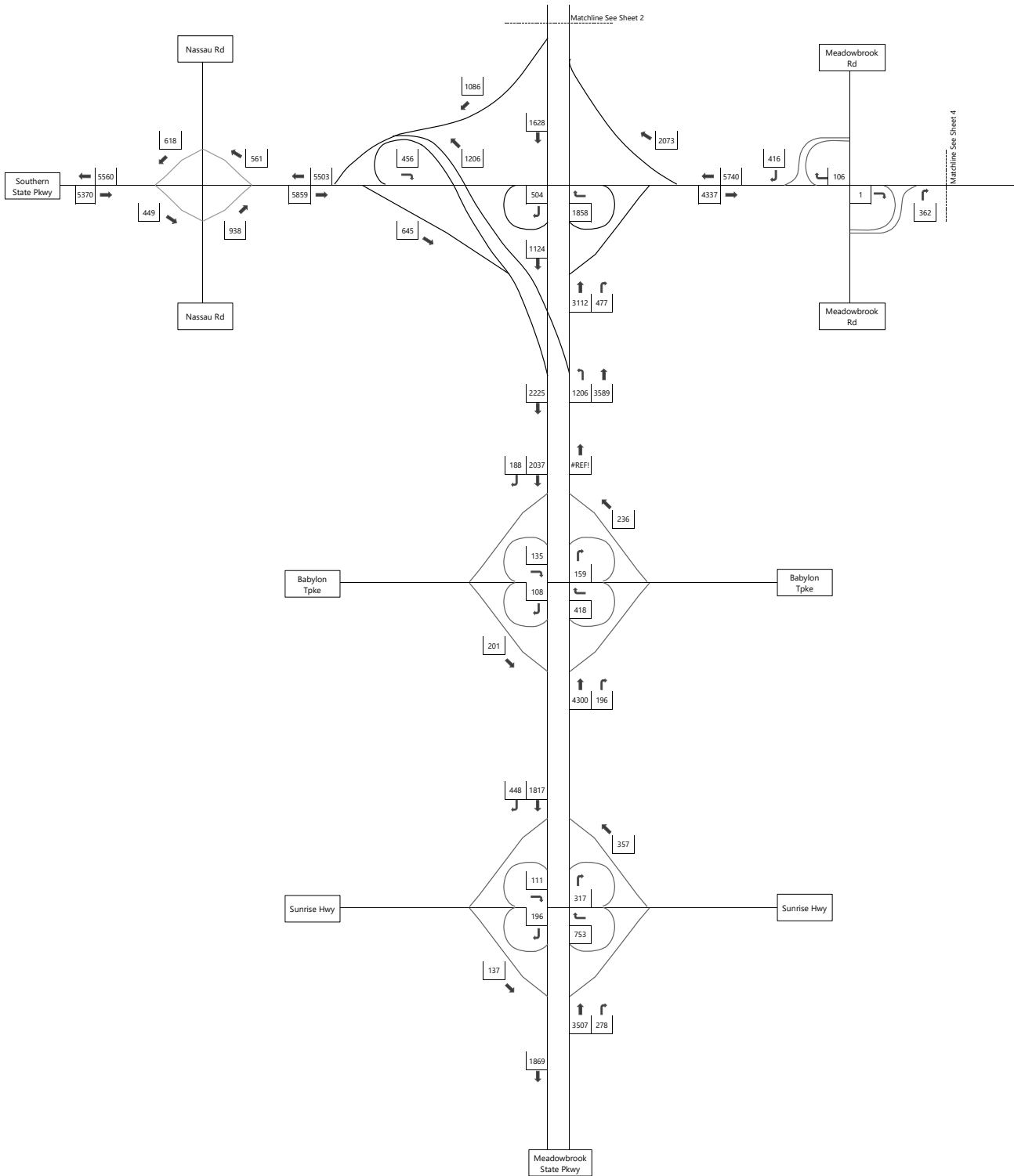

Figure V-E-8, Sheet 3
 2027 Build Parkway Traffic Volumes Weekday
 AM Peak Hour
 26841.01 - Sands New York Integrated Resort
 Meadowbrook State Parkway



Not to Scale



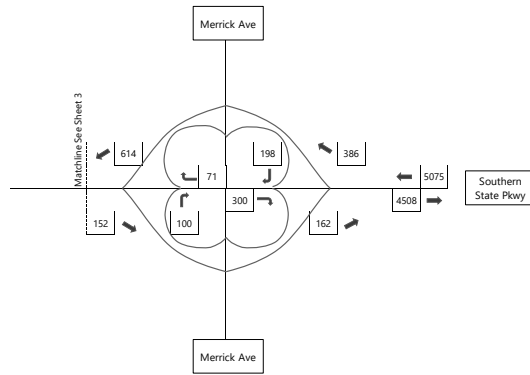
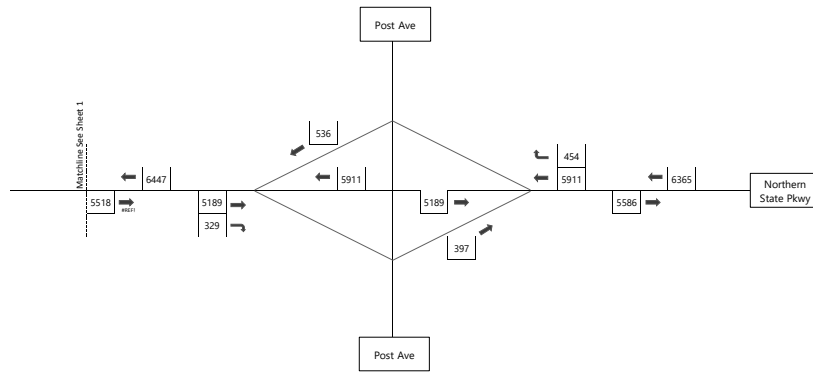

Figure V-E-8, Sheet 4
 2027 Build Parkway Traffic Volumes Weekday
 AM Peak Hour
 26841.01 - Sands New York Integrated Resort
 Meadowbrook State Parkway



Not to Scale



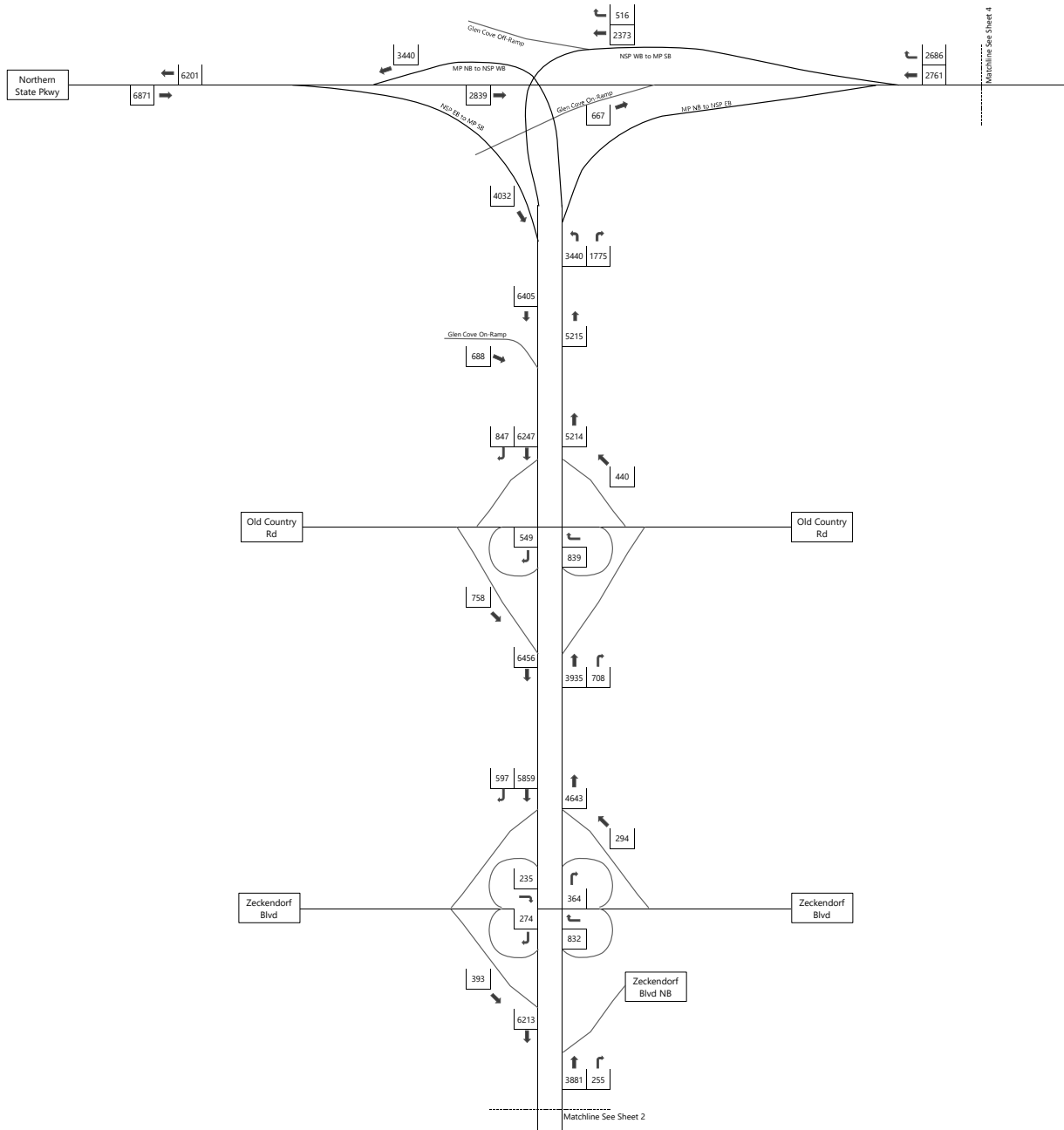

Figure V-E-9, Sheet 1
 2027 Build Parkway Traffic Volumes Weekday
 PM Peak Hour
 26841.01 - Sands New York Integrated Resort
 Meadowbrook State Parkway



Not to Scale



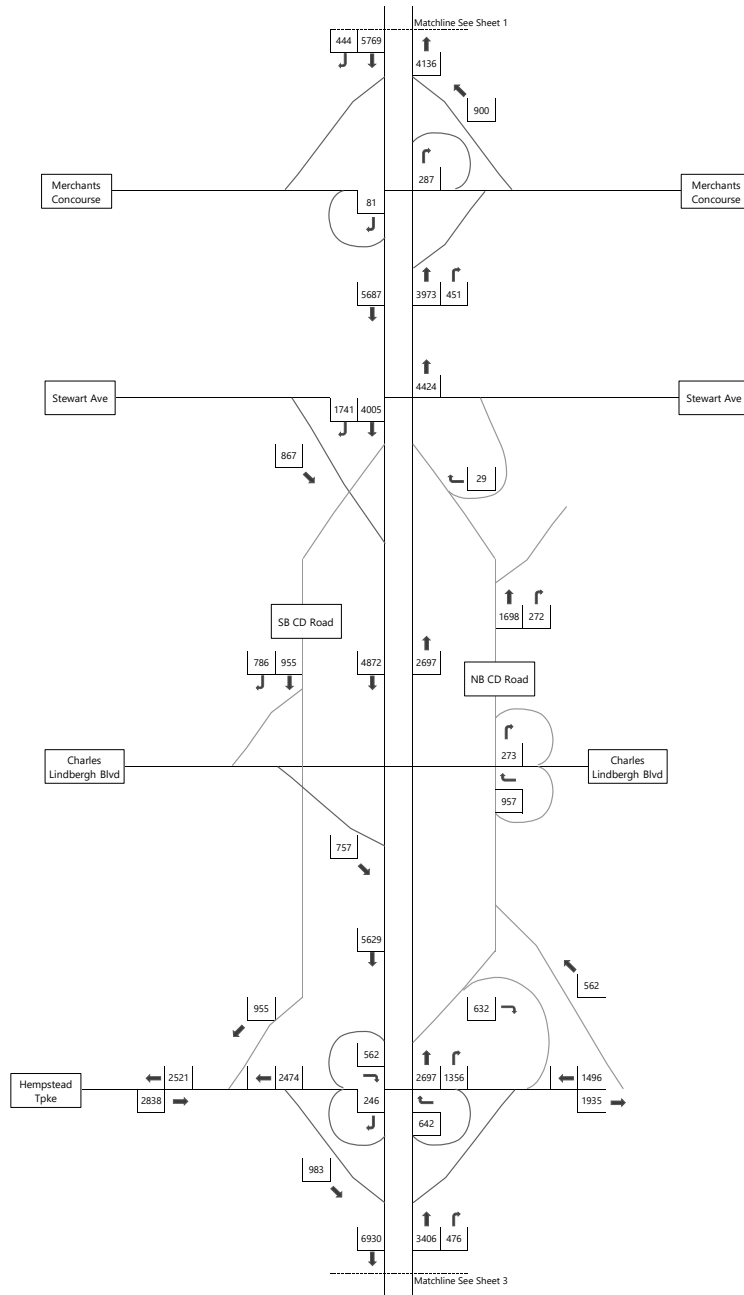

Figure V-E-9, Sheet 2
 2027 Build Parkway Traffic Volumes Weekday
 PM Peak Hour
 26841.01 - Sands New York Integrated Resort
 Meadowbrook State Parkway



Not to Scale



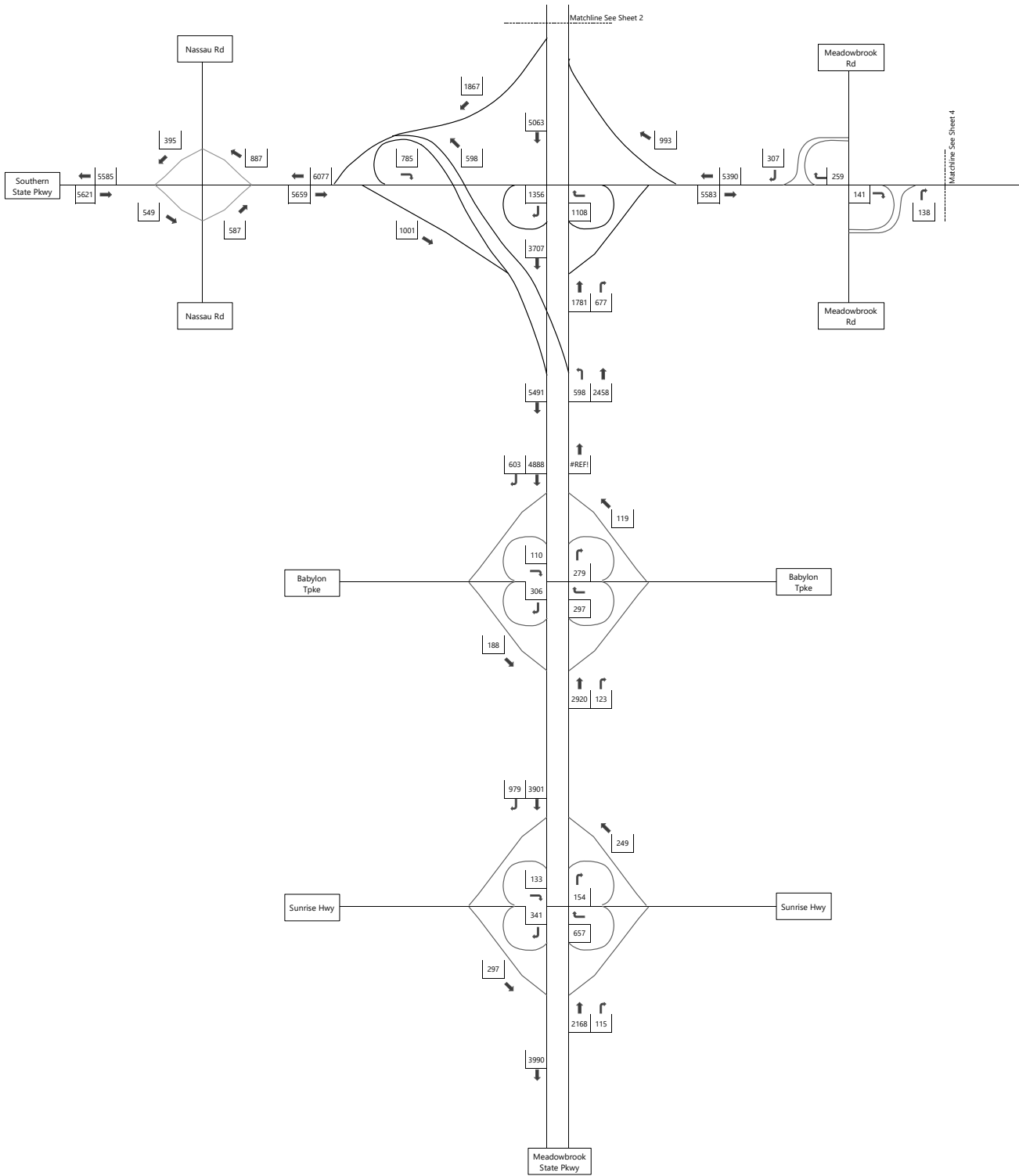

Figure V-E-9, Sheet 3
 2027 Build Parkway Traffic Volumes Weekday
 PM Peak Hour
 26841.01 - Sands New York Integrated Resort
 Meadowbrook State Parkway



Not to Scale



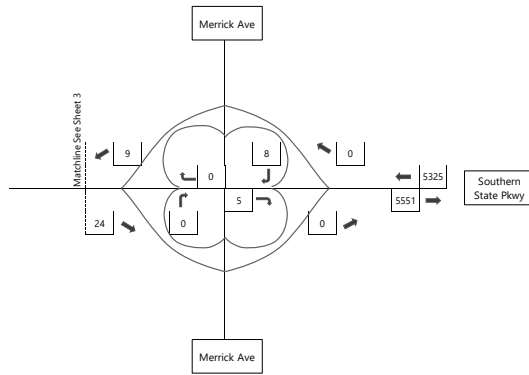
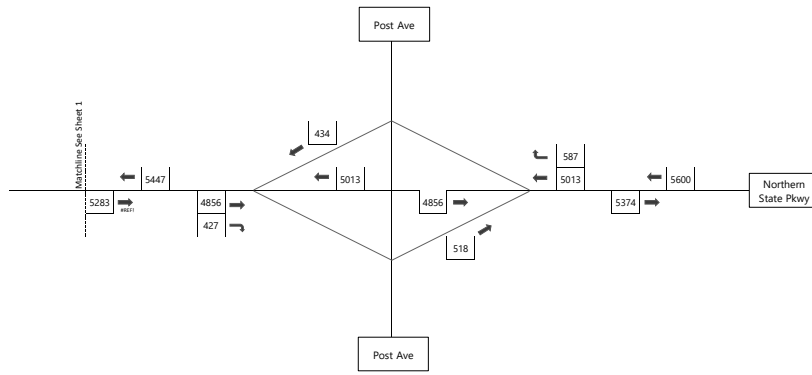

Figure V-E-9, Sheet 4
 2027 Build Parkway Traffic Volumes Weekday
 PM Peak Hour
 26841.01 - Sands New York Integrated Resort
 Meadowbrook State Parkway



Not to Scale



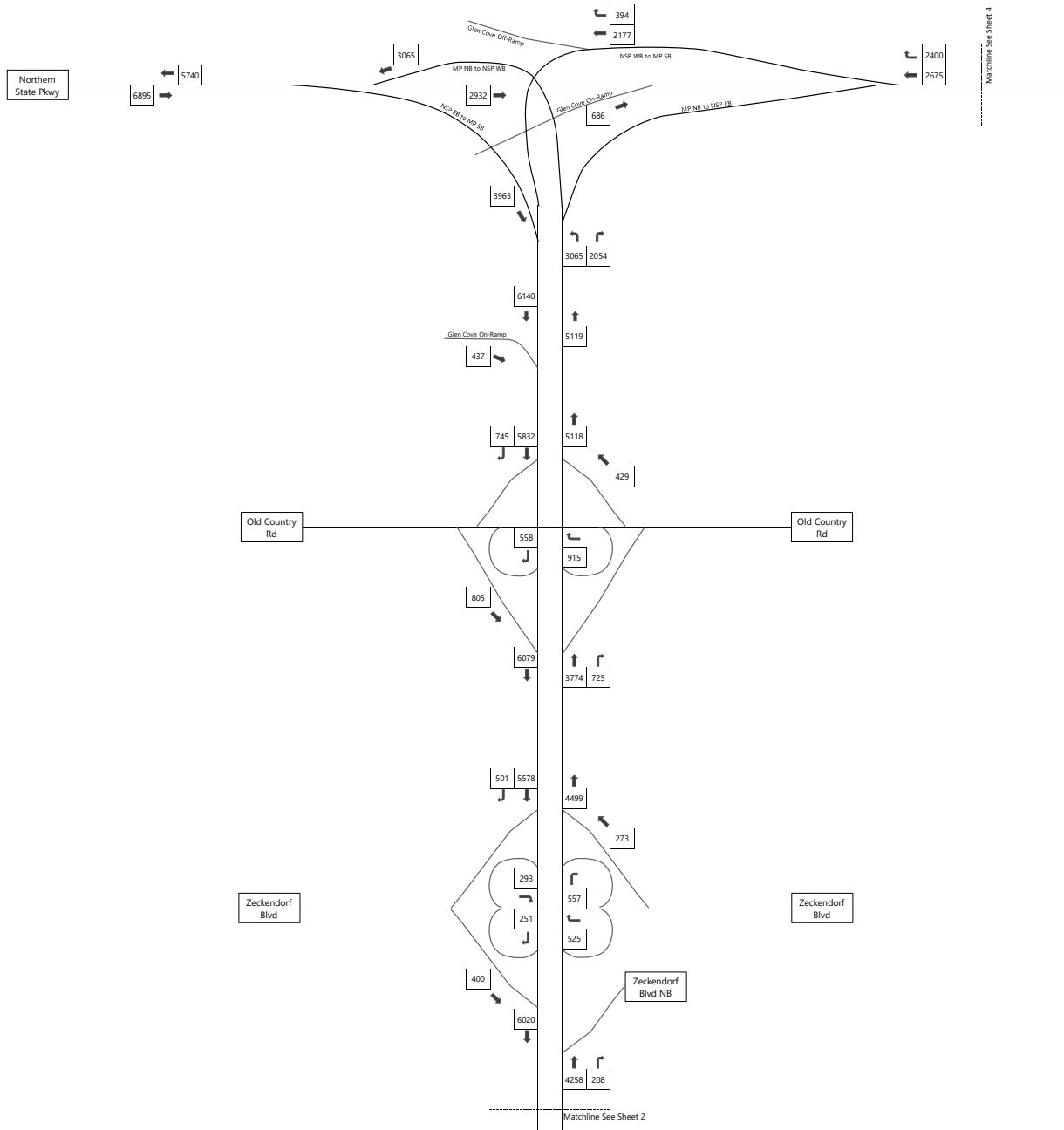

Figure V-E-10, Sheet 1
 2027 Build Parkway Traffic Volumes
 Friday Evening Peak Hour
 26841.01 - Sands New York Integrated Resort
 Meadowbrook State Parkway



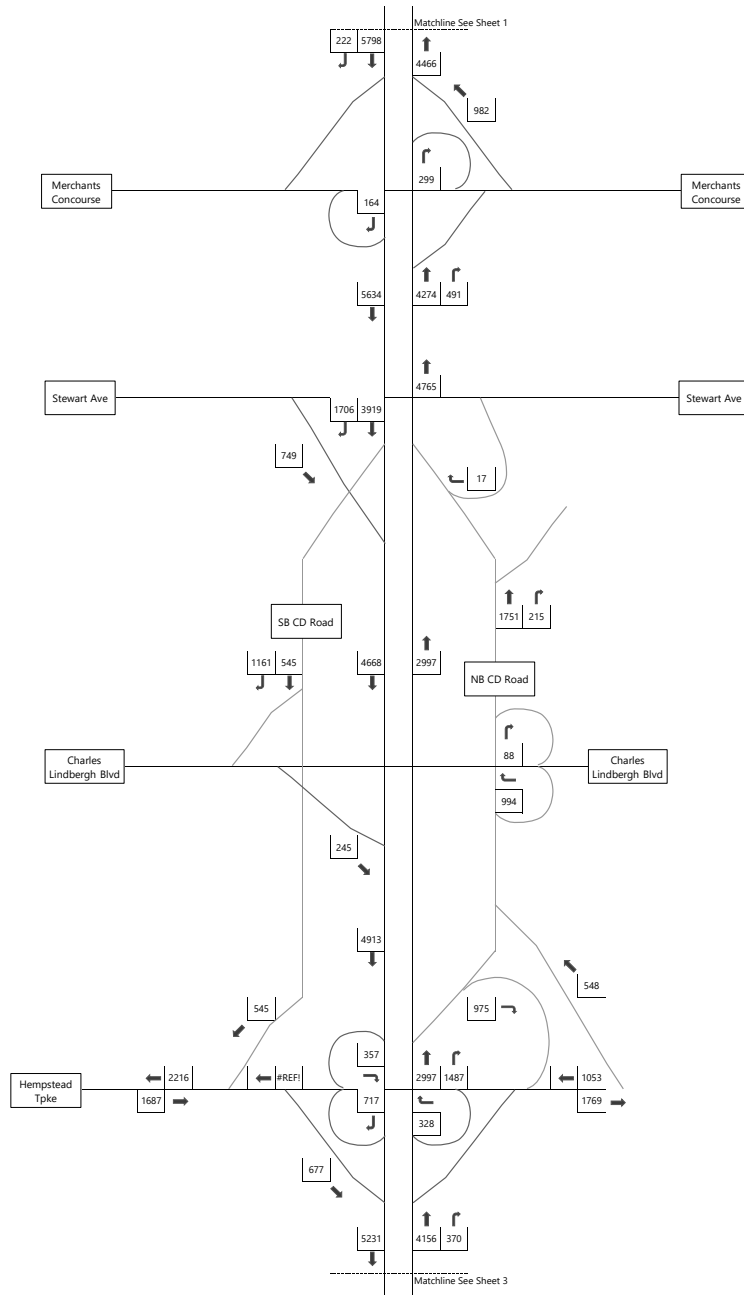

Figure V-E-10, Sheet 2
 2027 Build Parkway Traffic Volumes
 Friday Evening Peak Hour
 26841.01 - Sands New York Integrated Resort
 Meadowbrook State Parkway



Not to Scale



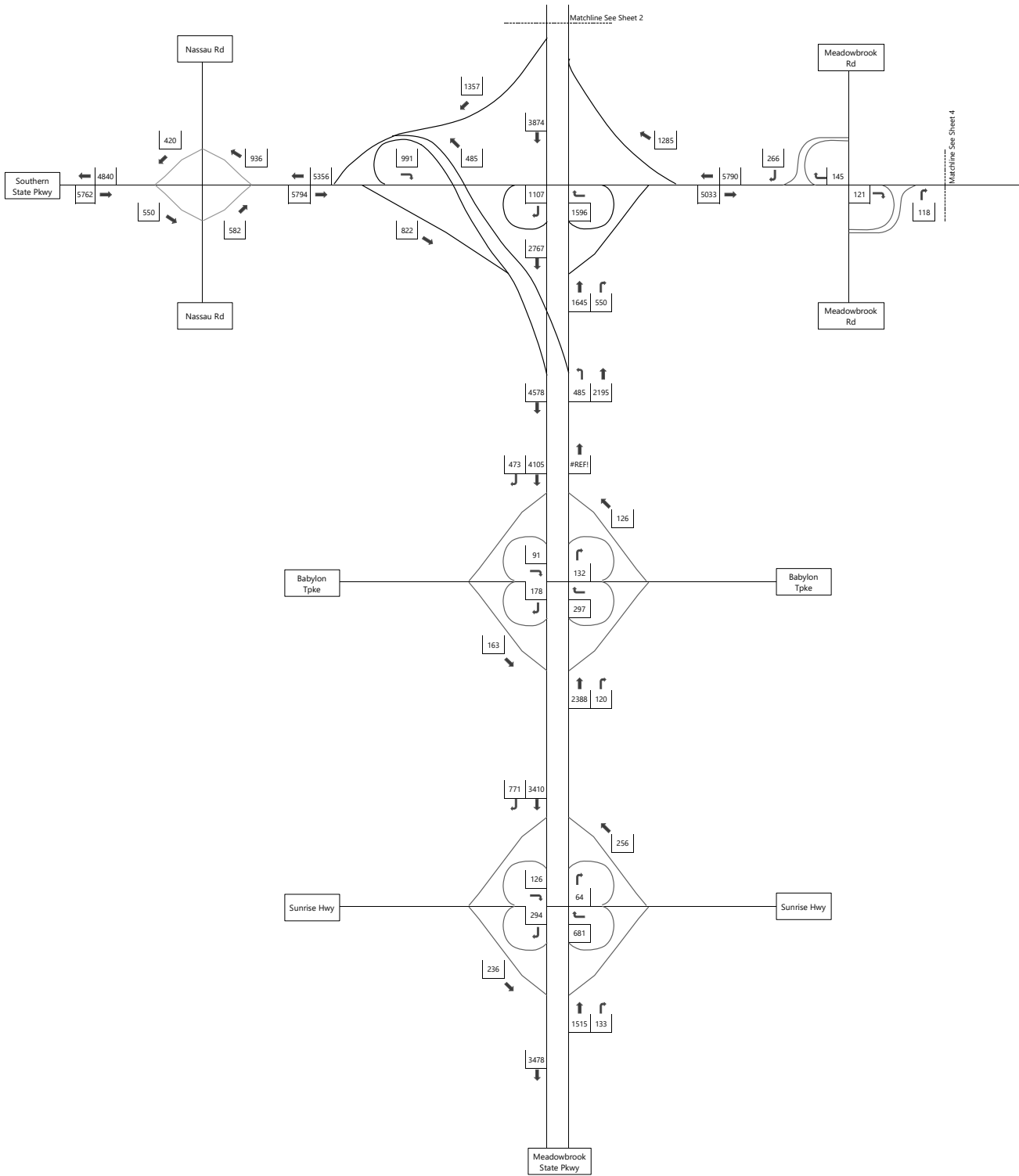

Figure V-E-10, Sheet 3
 2027 Build Parkway Traffic Volumes
 Friday Evening Peak Hour
 26841.01 - Sands New York Integrated Resort
 Meadowbrook State Parkway



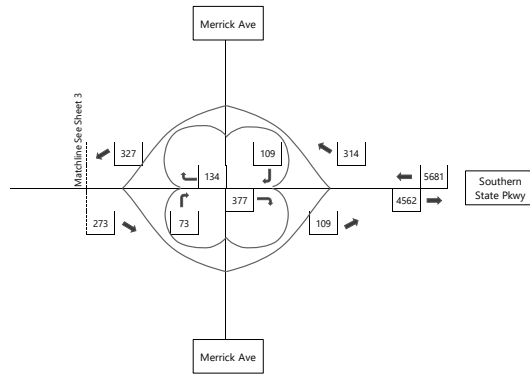
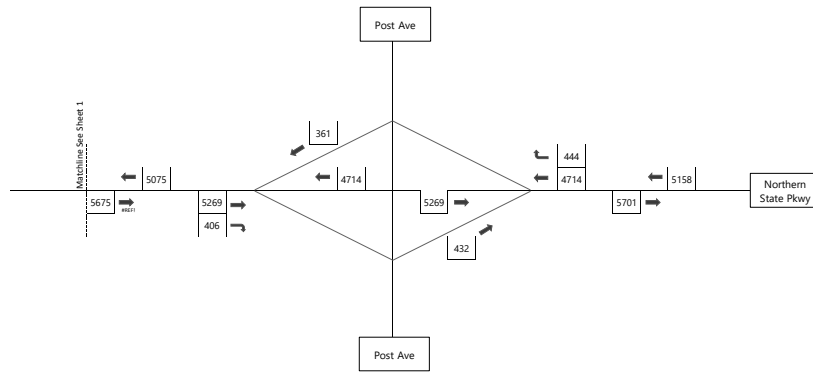

Figure V-E-10, Sheet 4
 2027 Build Parkway Traffic Volumes
 Friday Evening Peak Hour
 26841.01 - Sands New York Integrated Resort
 Meadowbrook State Parkway



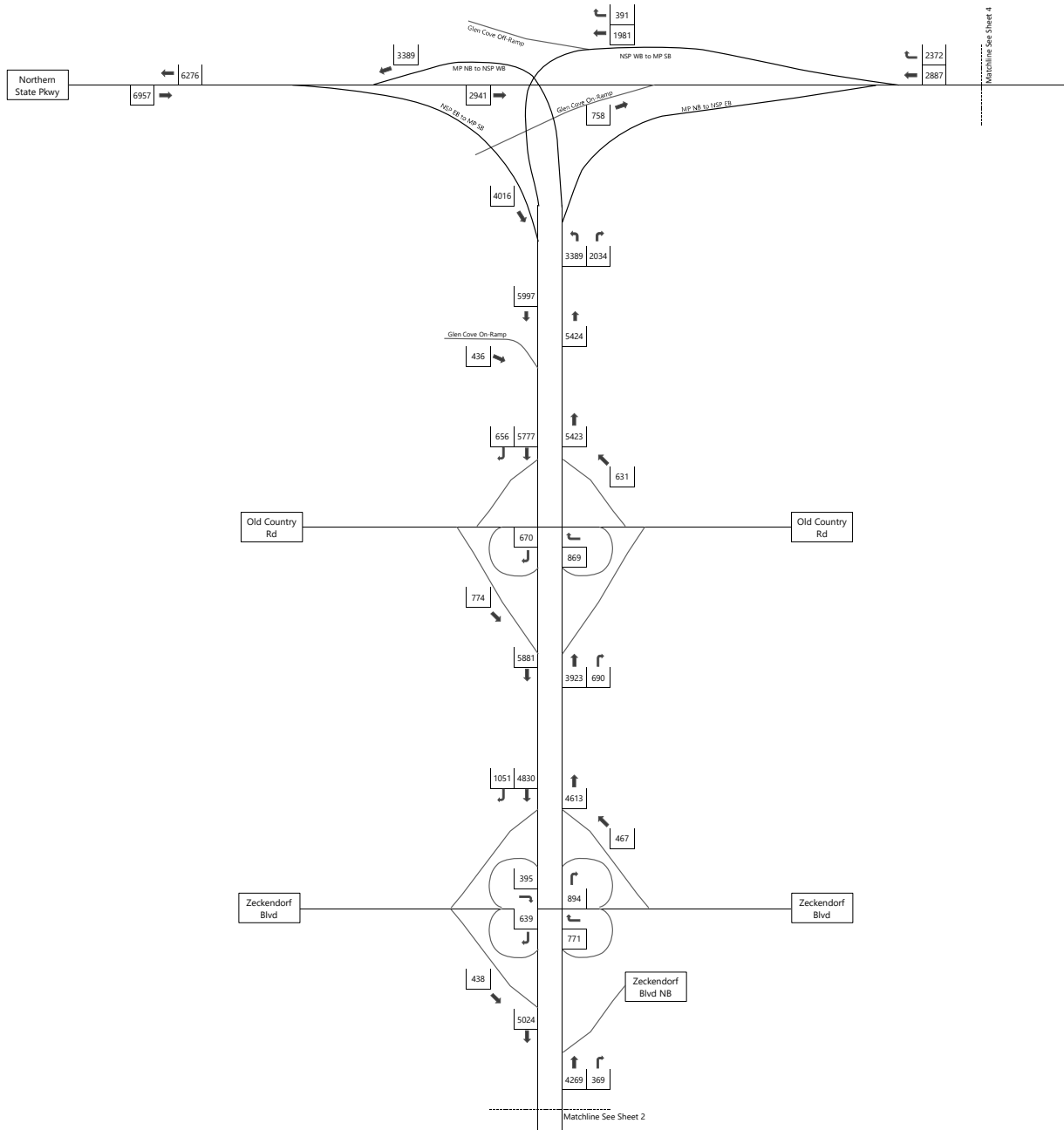

Figure V-E-11, Sheet 1
 2027 Build Parkway Traffic Volumes
 Saturday Midday Peak Hour
 26841.01 - Sands New York Integrated Resort
 Meadowbrook State Parkway



Not to Scale



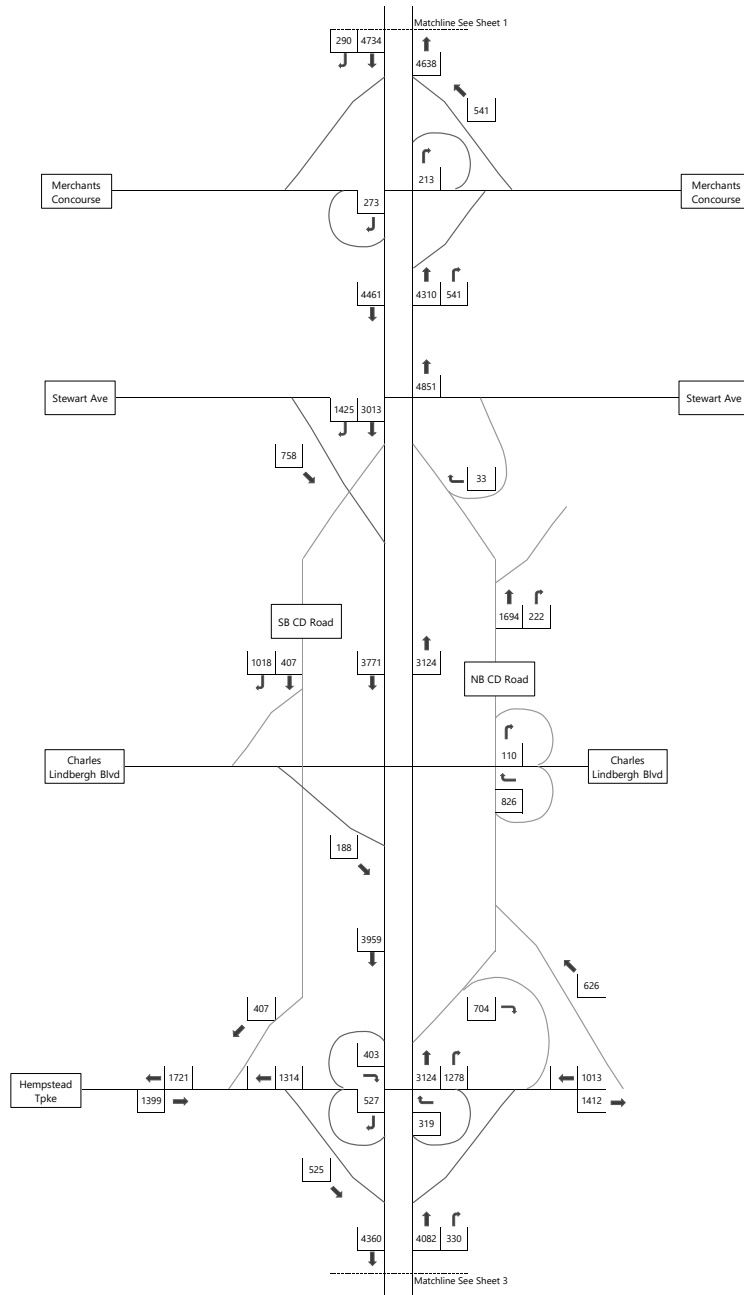

Figure V-E-11, Sheet 2
 2027 Build Parkway Traffic Volumes
 Saturday Midday Peak Hour
 26841.01 - Sands New York Integrated Resort
 Meadowbrook State Parkway



Not to Scale



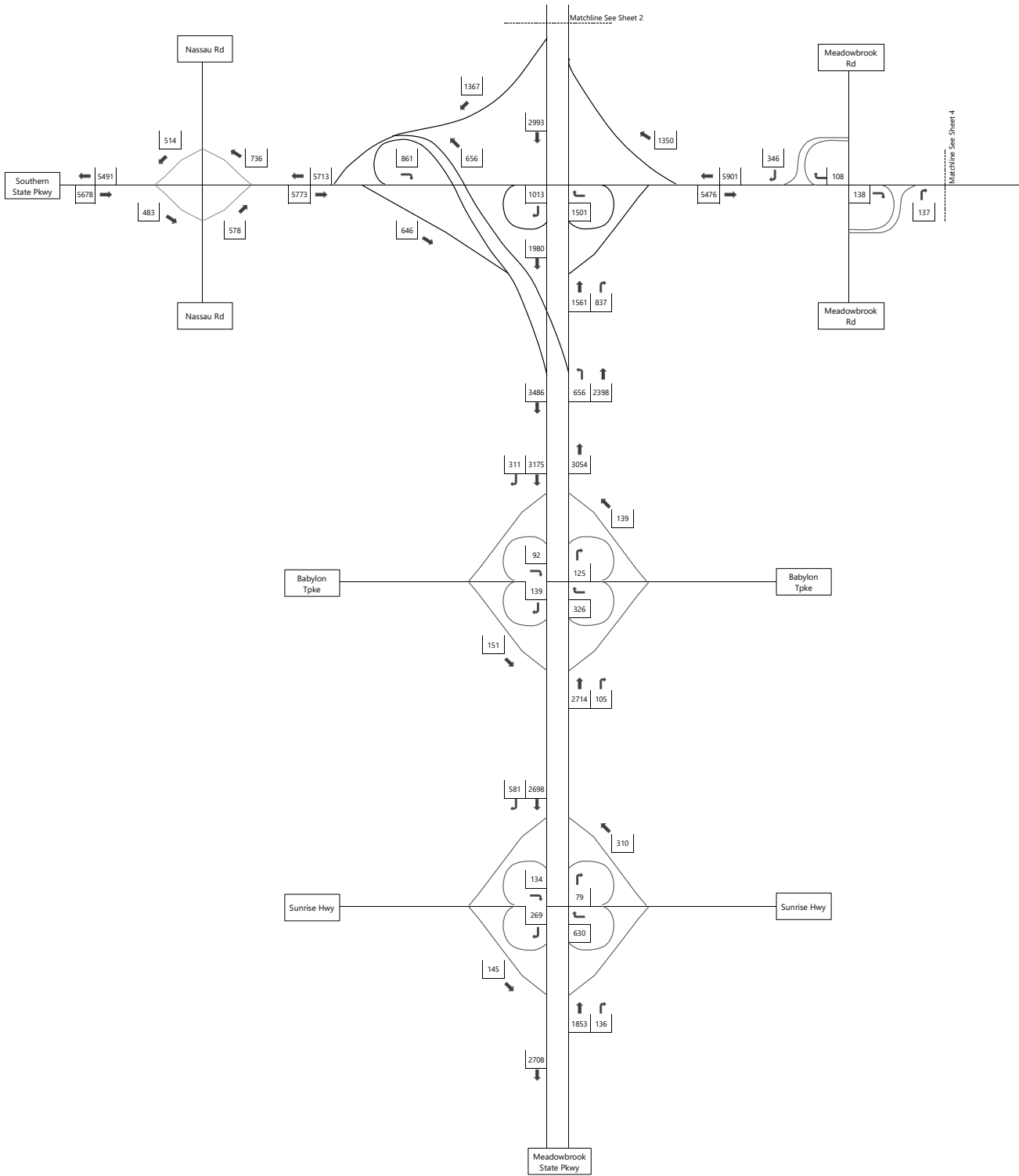

Figure V-E-11, Sheet 3
 2027 Build Parkway Traffic Volumes
 Saturday MIDDAY Peak Hour
 26841.01 - Sands New York Integrated Resort
 Meadowbrook State Parkway



Not to Scale



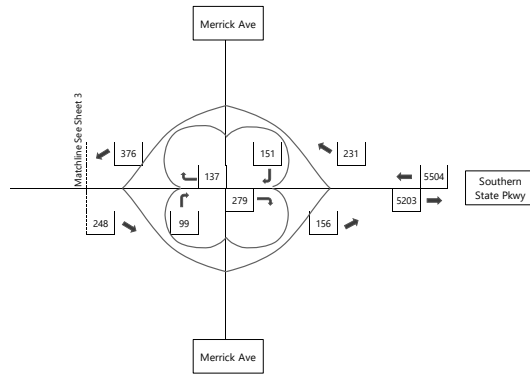
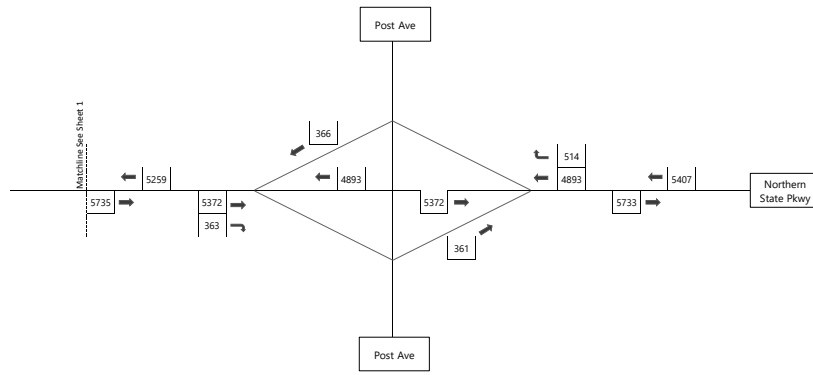

Figure V-E-11, Sheet 4
 2027 Build Parkway Traffic Volumes
 Saturday Midday Peak Hour
 26841.01 - Sands New York Integrated Resort
 Meadowbrook State Parkway



Not to Scale



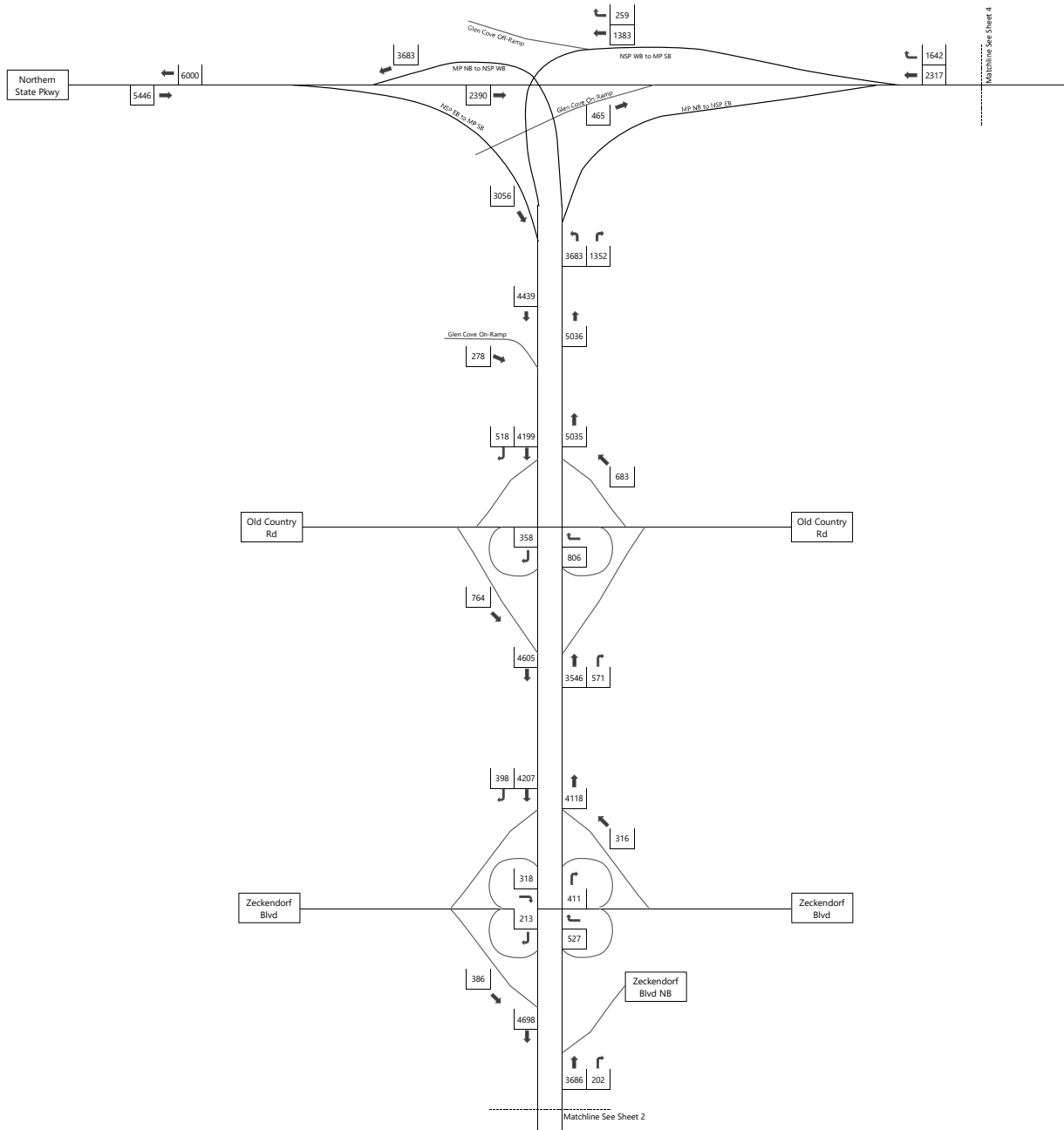

Figure V-E-12, Sheet 1
 2027 Build Parkway Traffic Volumes
 Saturday Evening Peak Hour
 26841.01 - Sands New York Integrated Resort
 Meadowbrook State Parkway



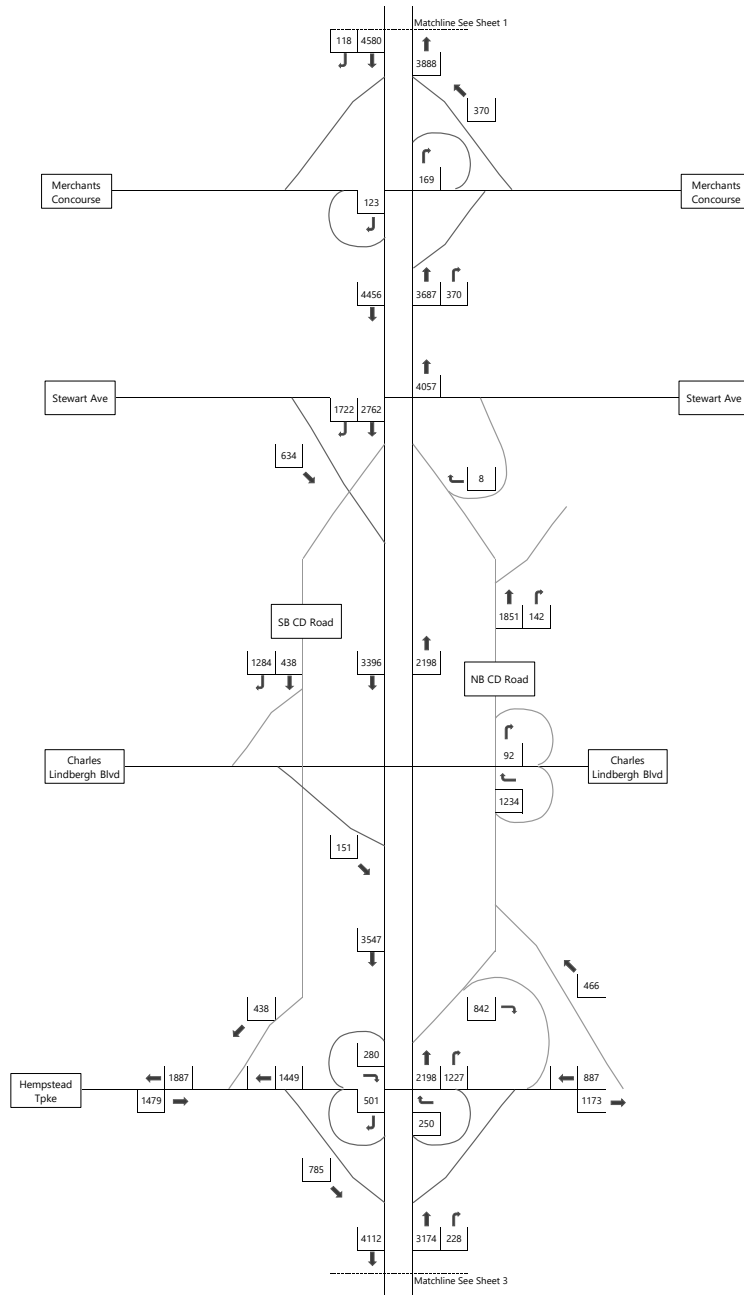

Figure V-E-12, Sheet 2
 2027 Build Parkway Traffic Volumes
 Saturday Evening Peak Hour
 26841.01 - Sands New York Integrated Resort
 Meadowbrook State Parkway



Not to Scale



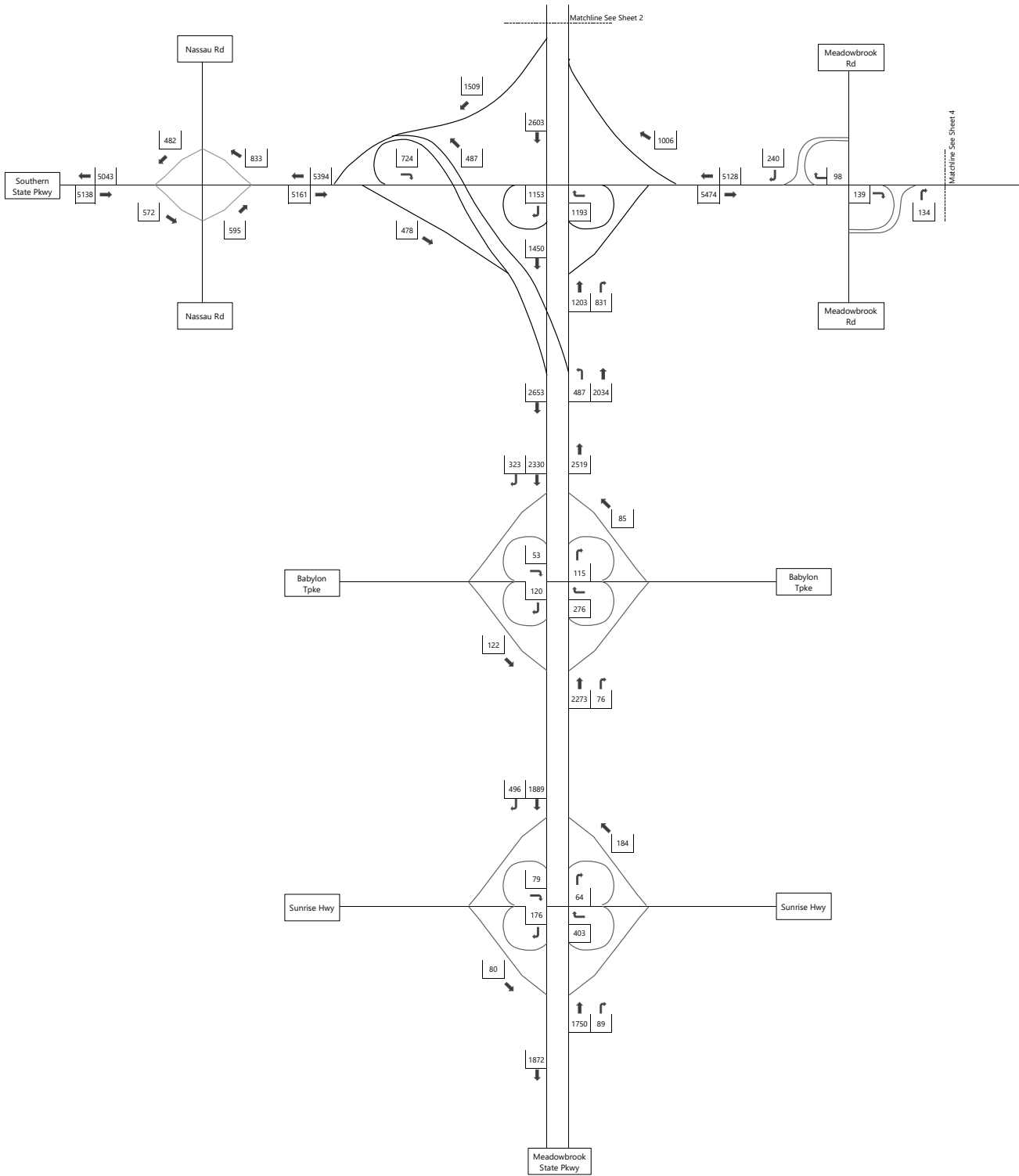

Figure V-E-12, Sheet 3
 2027 Build Parkway Traffic Volumes
 Saturday Evening Peak Hour
 26841.01 - Sands New York Integrated Resort
 Meadowbrook State Parkway



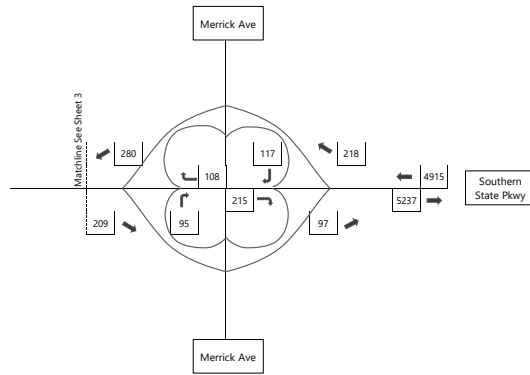
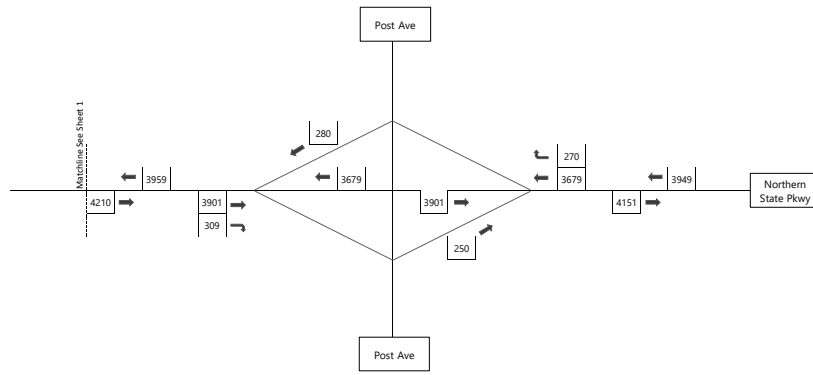

Figure V-E-12, Sheet 4
 2027 Build Parkway Traffic Volumes
 Saturday Evening Peak Hour
 26841.01 - Sands New York Integrated Resort
 Meadowbrook State Parkway



Not to Scale



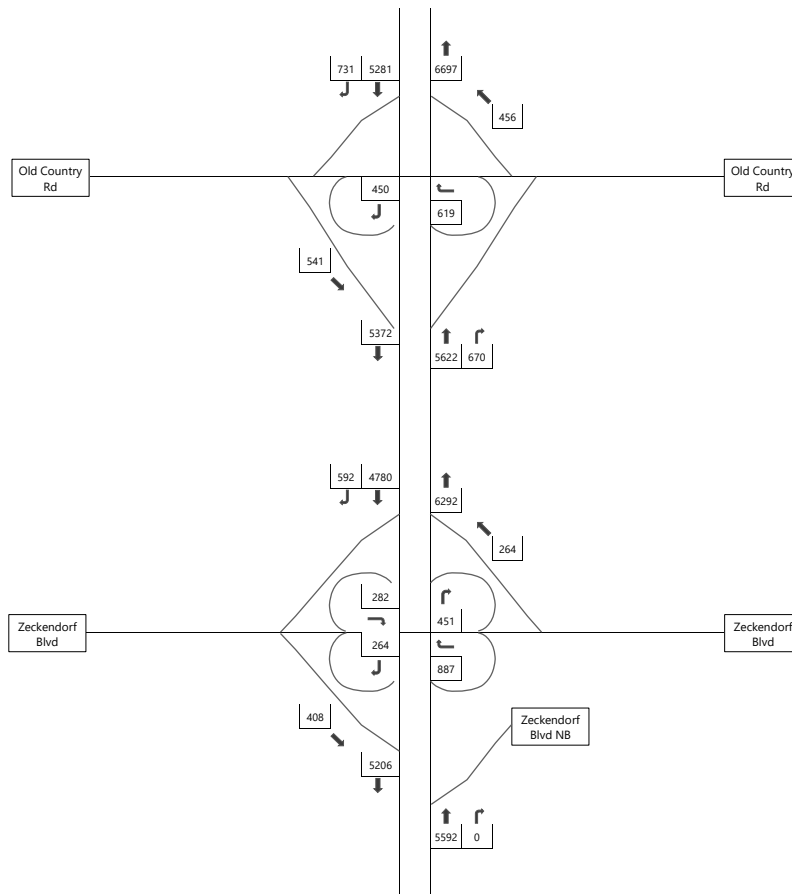

Figure V-E-13, Sheet 1
 2027 Build Parkway Traffic Volumes
 Weekday PM Peak Hour - Holiday 26841.01 -
 Sands New York Integrated Resort
 Meadowbrook State Parkway



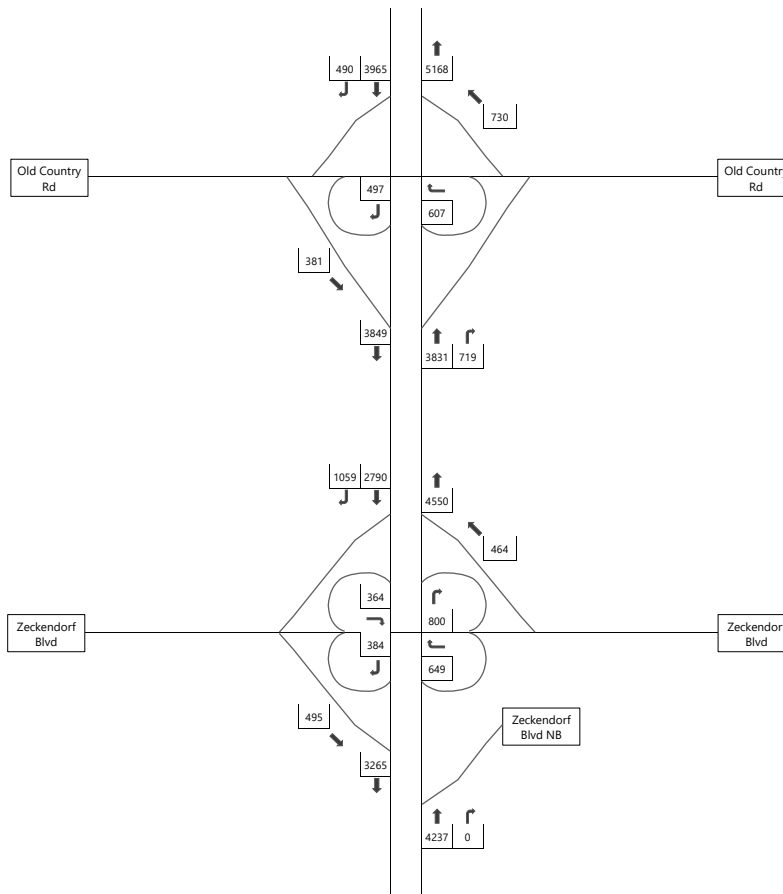

Figure V-E-14, Sheet 1
 2027 Build Parkway Traffic Volumes
 Saturday Midday Peak Hour - Holiday
 26841.01 - Sands New York Integrated Resort
 Meadowbrook State Parkway





V-F Alternative Analysis Trip Assignment

**26841.01: Sands Integrated Resort
Traffic Impact Study Attachments
Attachment F – Parkway Peak Hour Traffic Volume Figures**



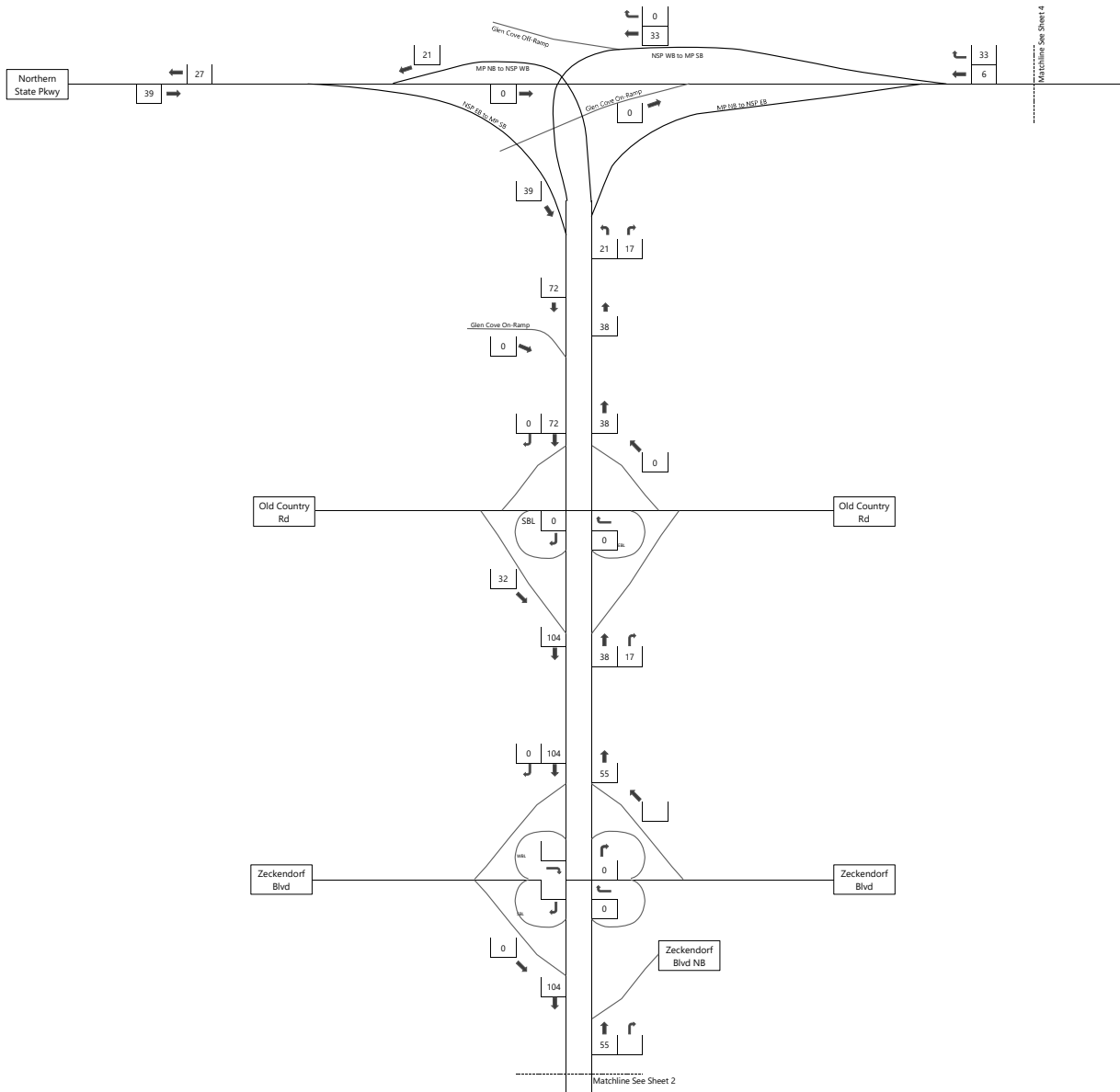

Figure V-F-1, Sheet 1
 2030 Parkway Trip Assignment - Alternative
 Weekday AM Peak Hour
 26841.01 - Sands New York Integrated Resort
 Meadowbrook State Parkway



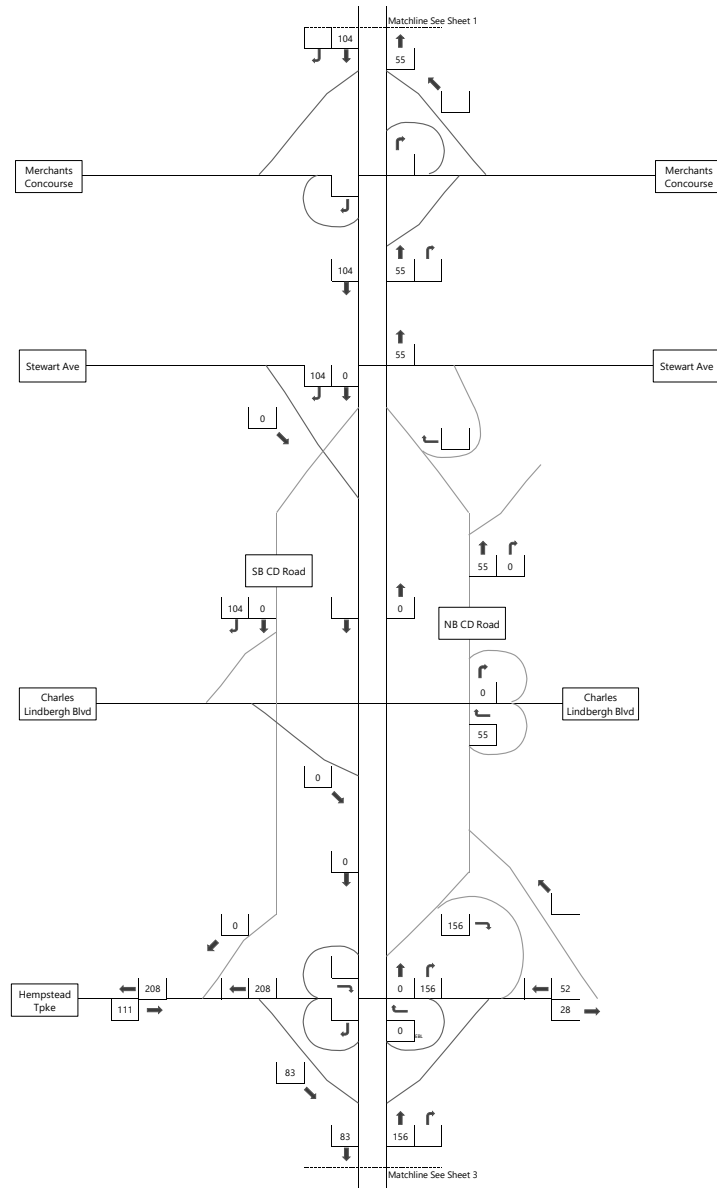

Figure V-F-1, Sheet 2

2030 Parkway Trip Assignment - Alternative
 Weekday AM Peak Hour
 26841.01 - Sands New York Integrated Resort
 Meadowbrook State Parkway



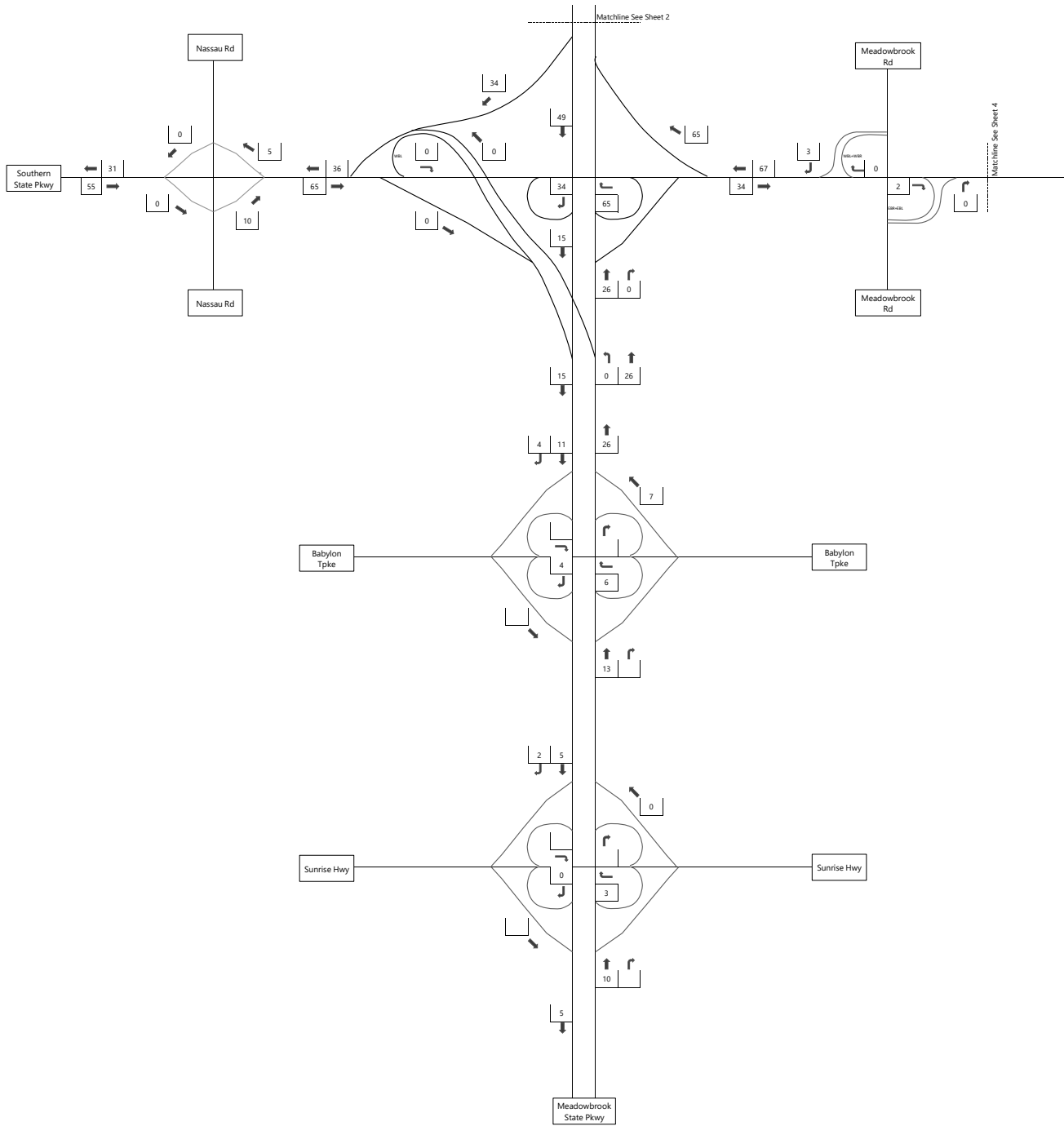

Figure V-F-1, Sheet 3
 2030 Parkway Trip Assignment - Alternative
 Weekday AM Peak Hour
 26841.01 - Sands New York Integrated Resort
 Meadowbrook State Parkway



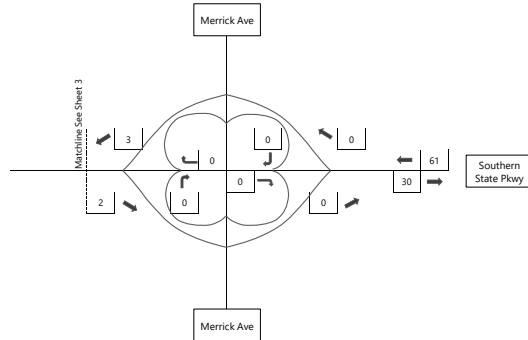
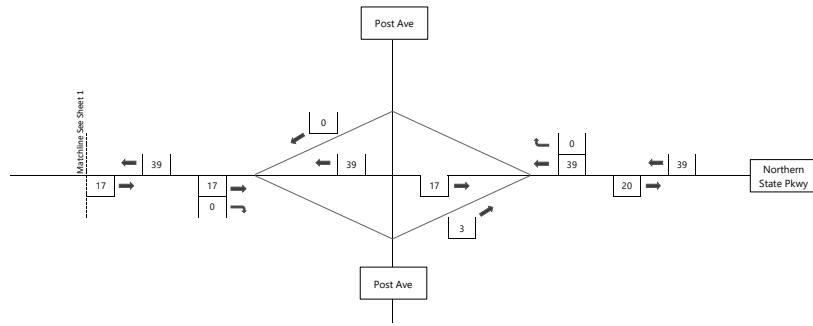

Figure V-F-1, Sheet 4
 2030 Parkway Trip Assignment - Alternative
 Weekday AM Peak Hour
 26841.01 - Sands New York Integrated Resort
 Meadowbrook State Parkway



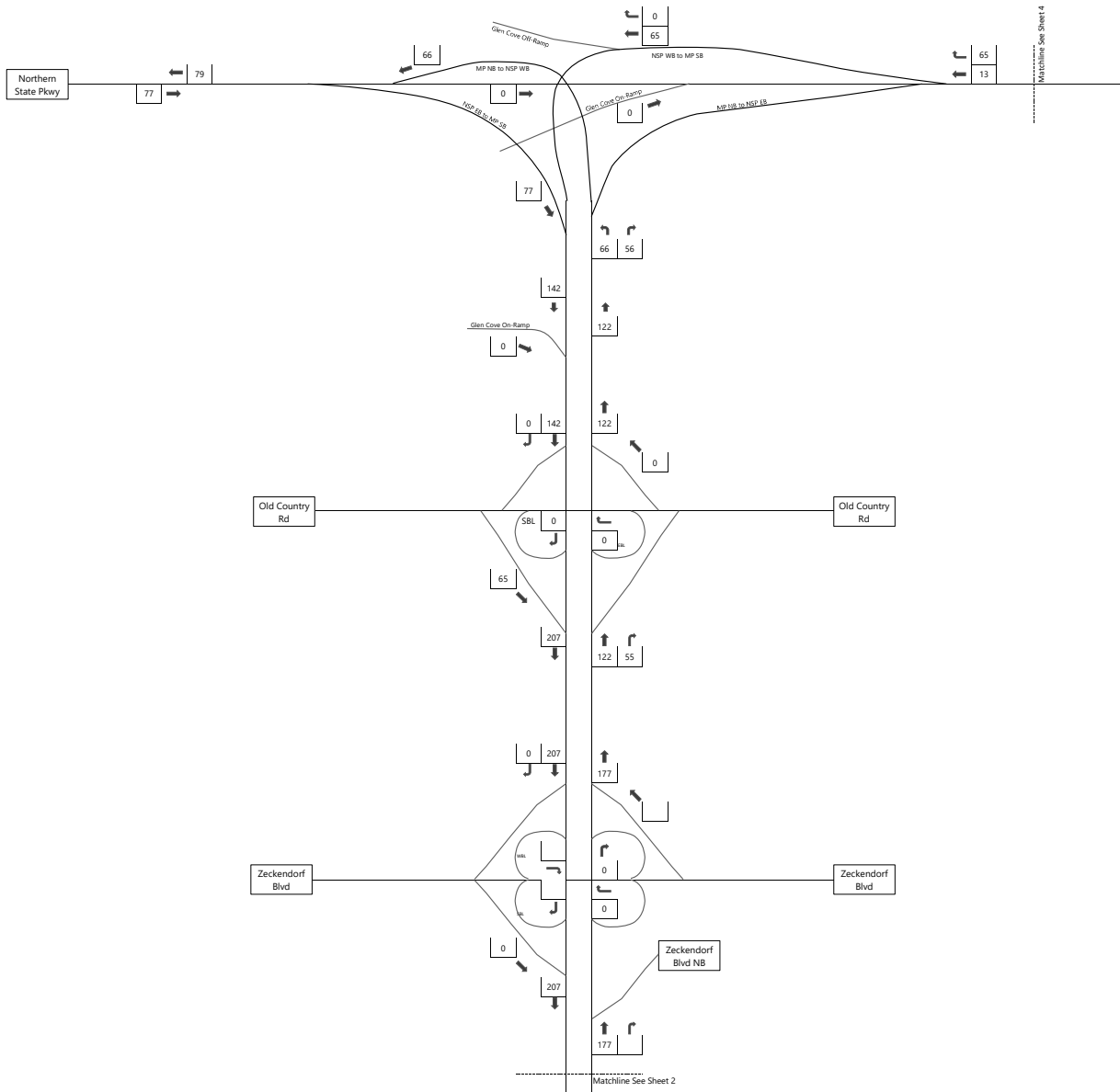

Figure V-F-2, Sheet 1
 2030 Parkway Trip Assignment - Alternative
 Weekday PM Peak Hour
 26841.01 - Sands New York Integrated Resort
 Meadowbrook State Parkway



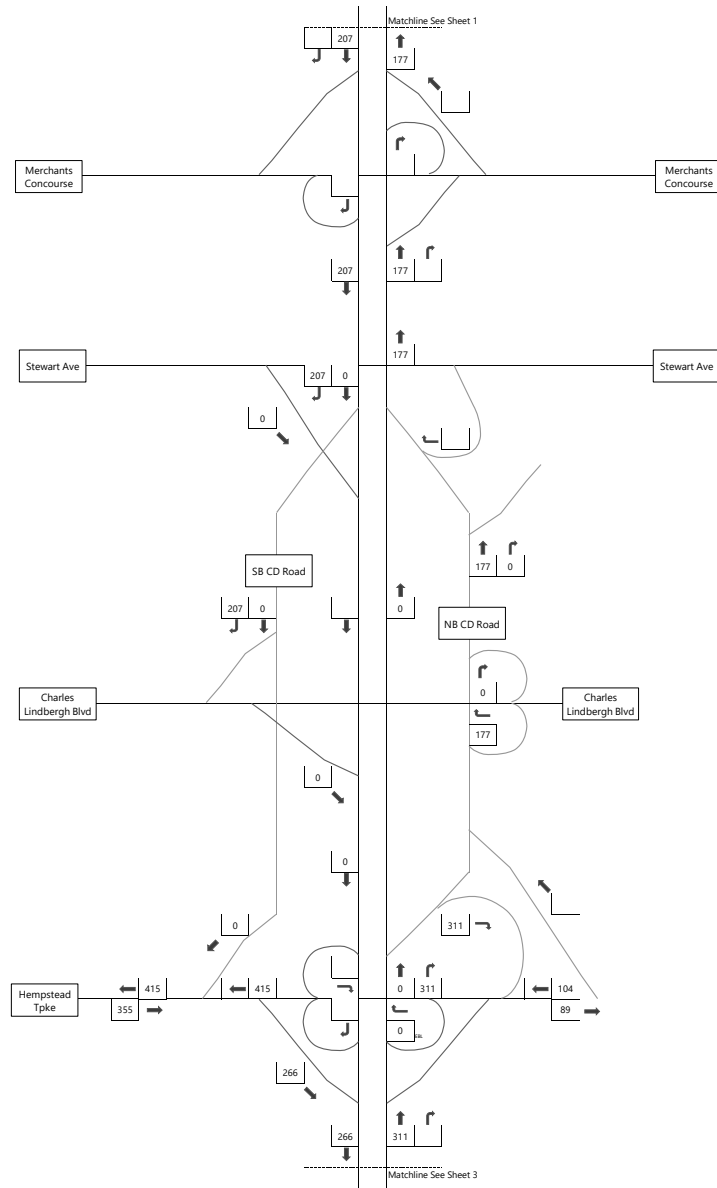

Figure V-F-2, Sheet 2
 2030 Parkway Trip Assignment - Alternative
 Weekday PM Peak Hour
 26841.01 - Sands New York Integrated Resort
 Meadowbrook State Parkway



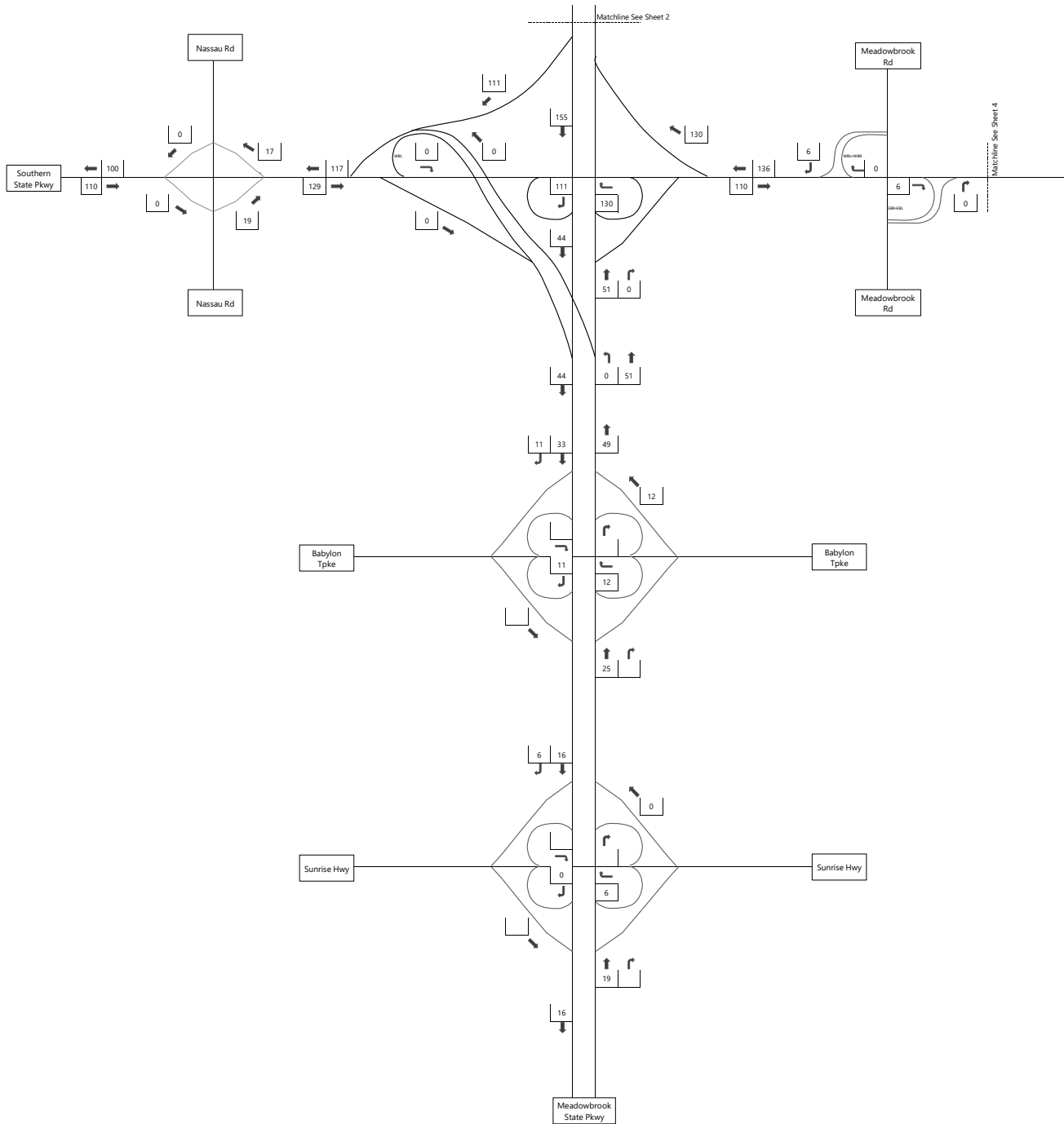

Figure V-F-2, Sheet 3
 2030 Parkway Trip Assignment - Alternative
 Weekday PM Peak Hour
 26841.01 - Sands New York Integrated Resort
 Meadowbrook State Parkway



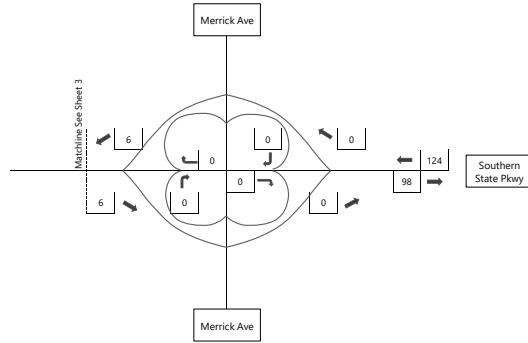
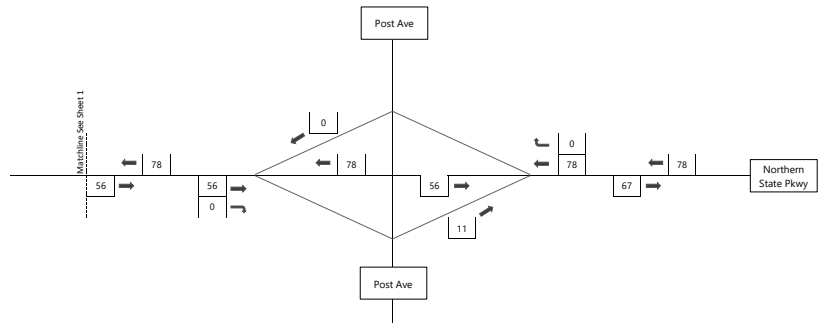

Figure V-F-2, Sheet 4
 2030 Parkway Trip Assignment - Alternative
 Weekday PM Peak Hour
 26841.01 - Sands New York Integrated Resort
 Meadowbrook State Parkway



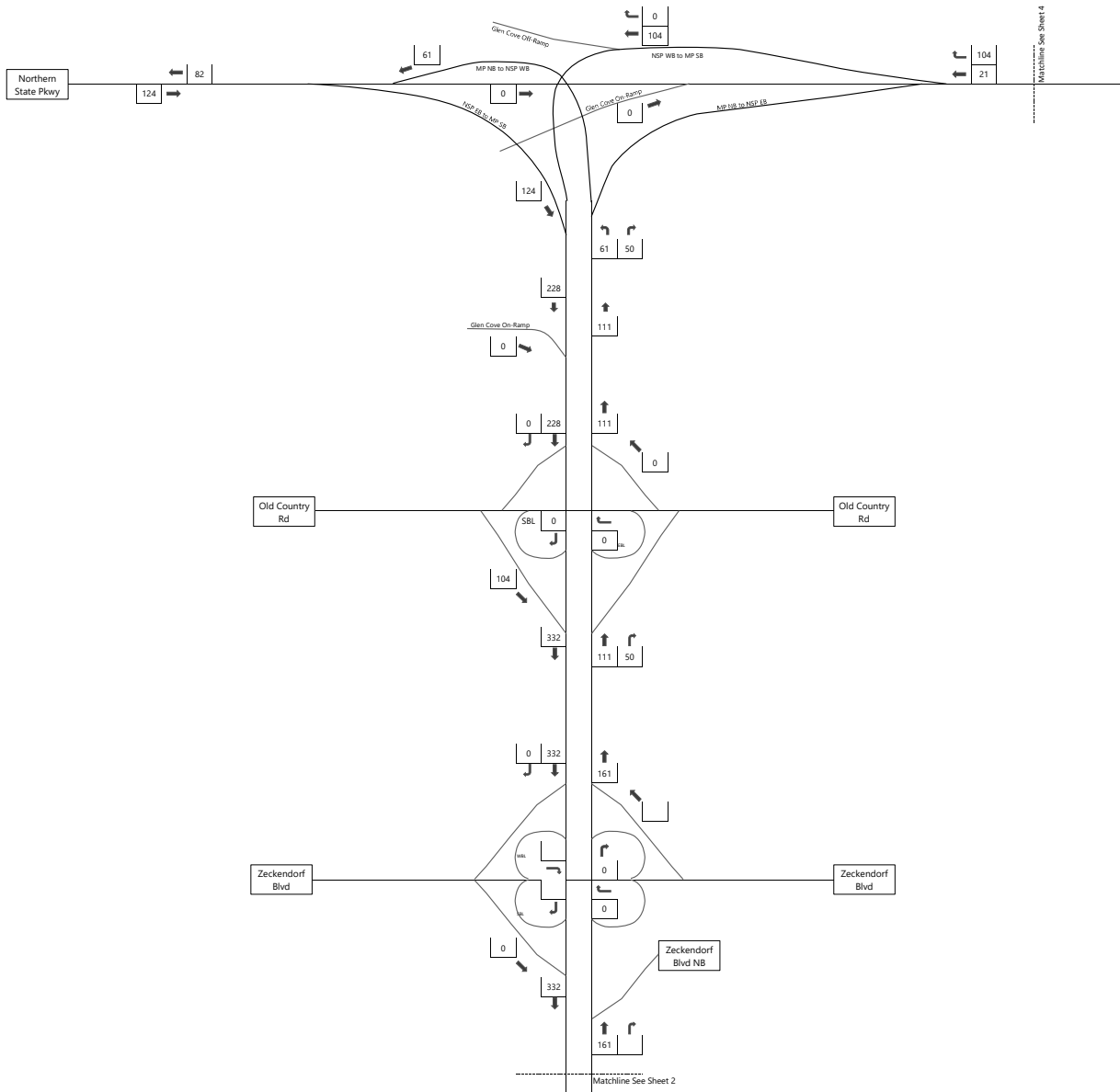

Figure V-F-3, Sheet 1
 2030 Parkway Trip Assignment - Alternative
 Saturday Midday Peak Hour
 26841.01 - Sands New York Integrated Resort
 Meadowbrook State Parkway



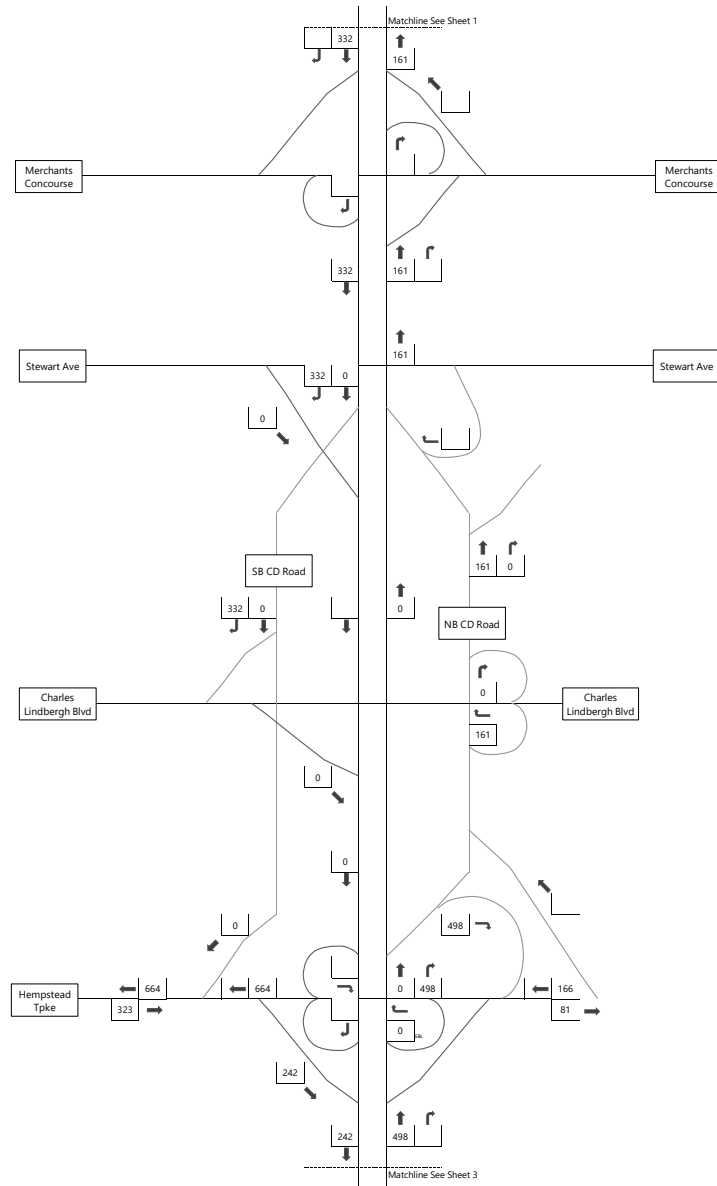

Figure V-F-3, Sheet 2
 2030 Parkway Trip Assignment - Alternative
 Saturday Midday Peak Hour
 26841.01 - Sands New York Integrated Resort
 Meadowbrook State Parkway



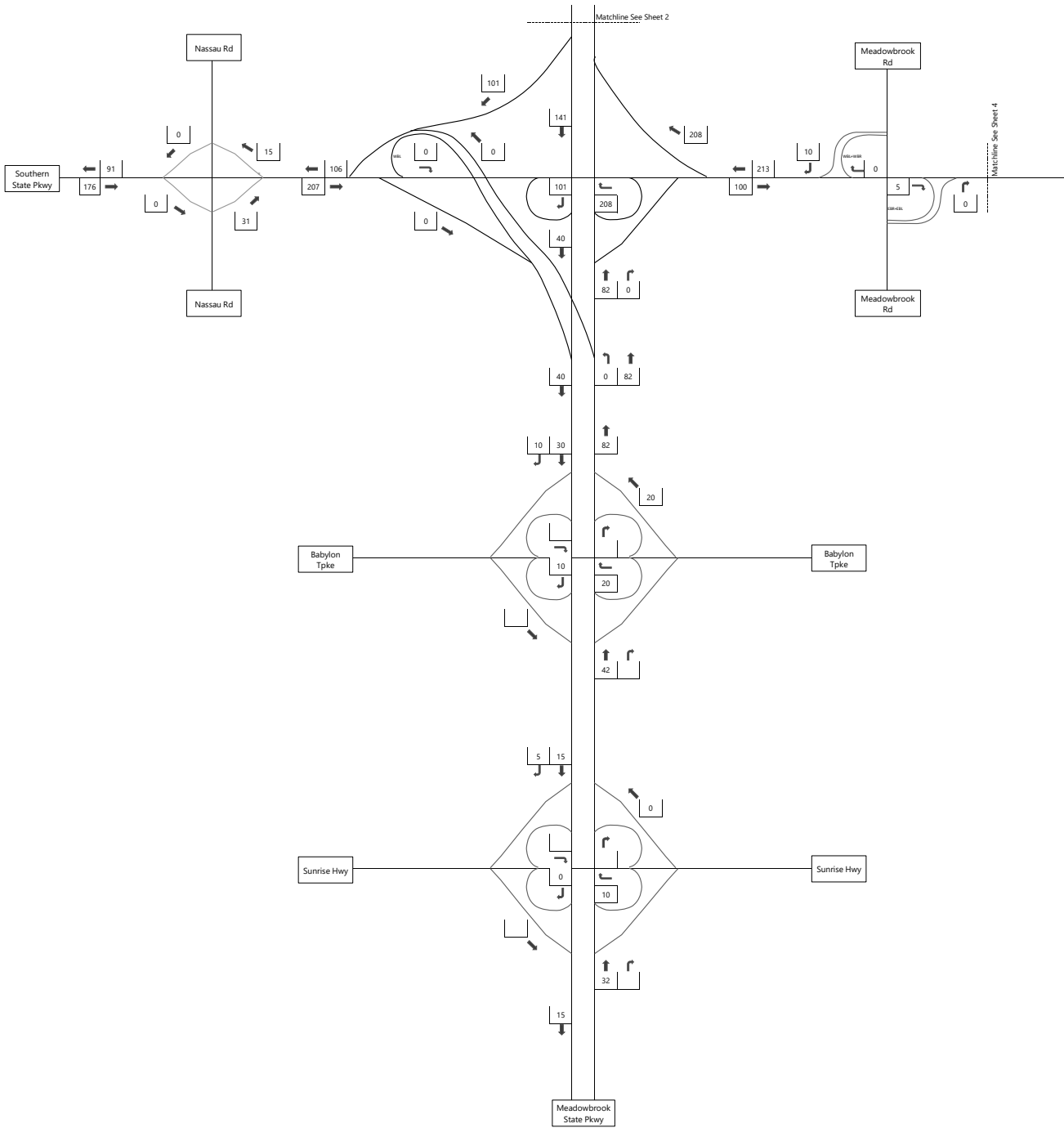

Figure V-F-3, Sheet 3
 2030 Parkway Trip Assignment - Alternative
 Saturday Midday Peak Hour
 26841.01 - Sands New York Integrated Resort
 Meadowbrook State Parkway



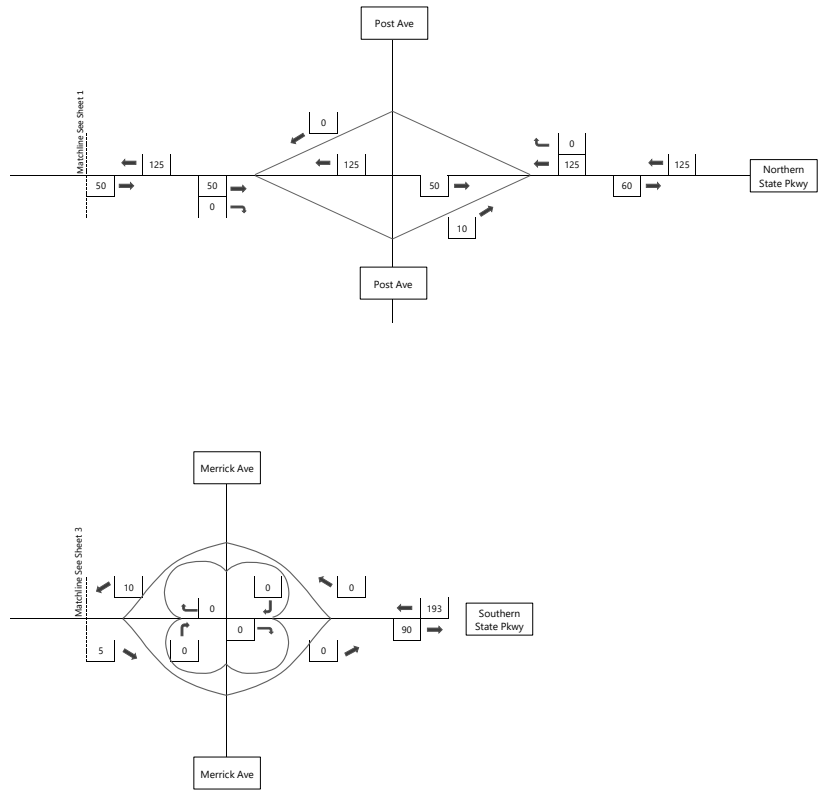

Figure V-F-3, Sheet 4
 2030 Parkway Trip Assignment - Alternative
 Saturday Midday Peak Hour
 26841.01 - Sands New York Integrated Resort
 Meadowbrook State Parkway





V-G Alternative Analysis Build Traffic Volumes

**26841.01: Sands Integrated Resort
Traffic Impact Study Attachments
Attachment F – Parkway Peak Hour Traffic Volume Figures**



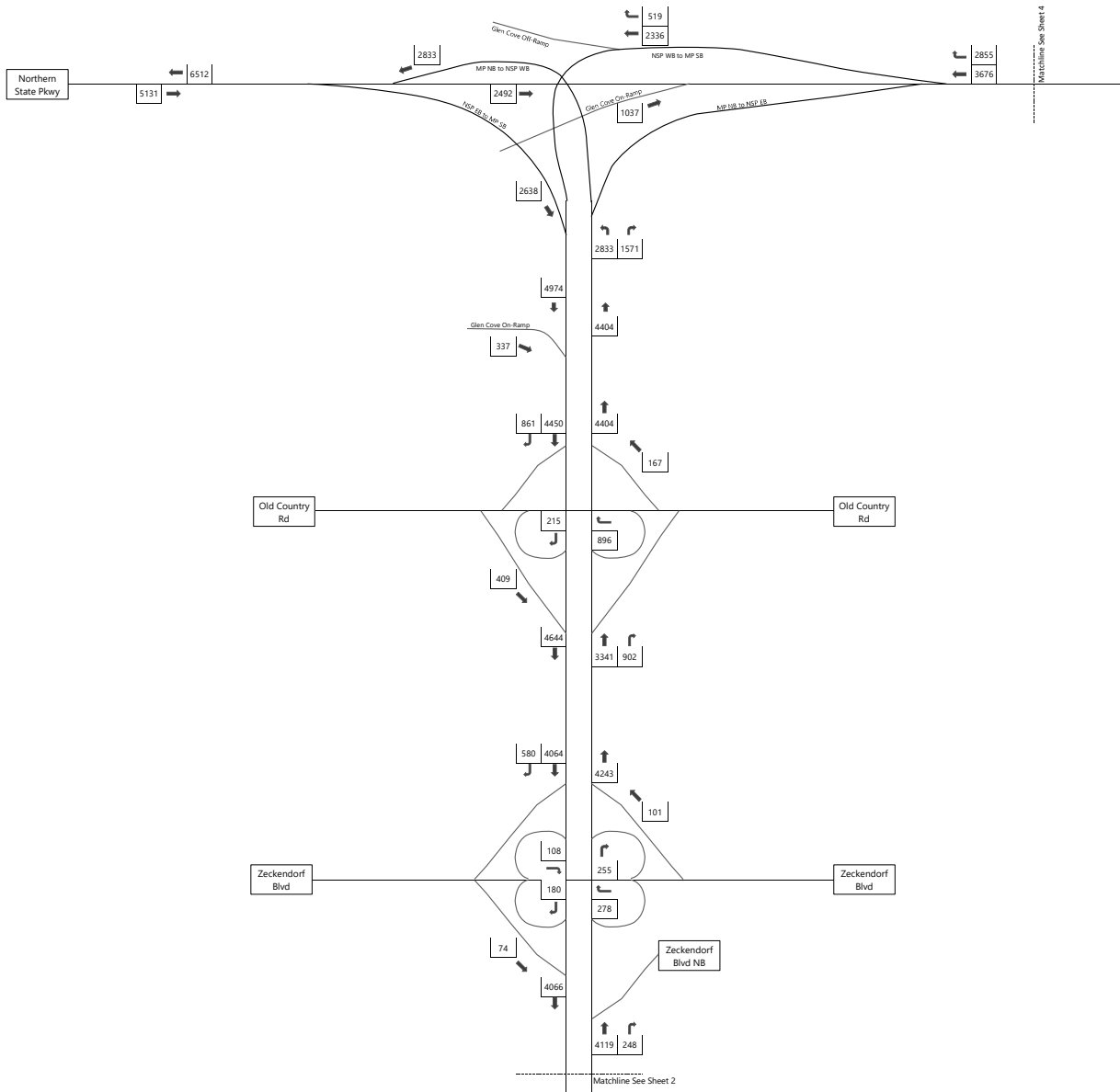

Figure V-G-1, Sheet 1
 2030 Build Parkway Traffic Volumes - Alternative
 Weekday AM Peak Hour
 26841.01 - Sands New York Integrated Resort
 Meadowbrook State Parkway



Not to Scale



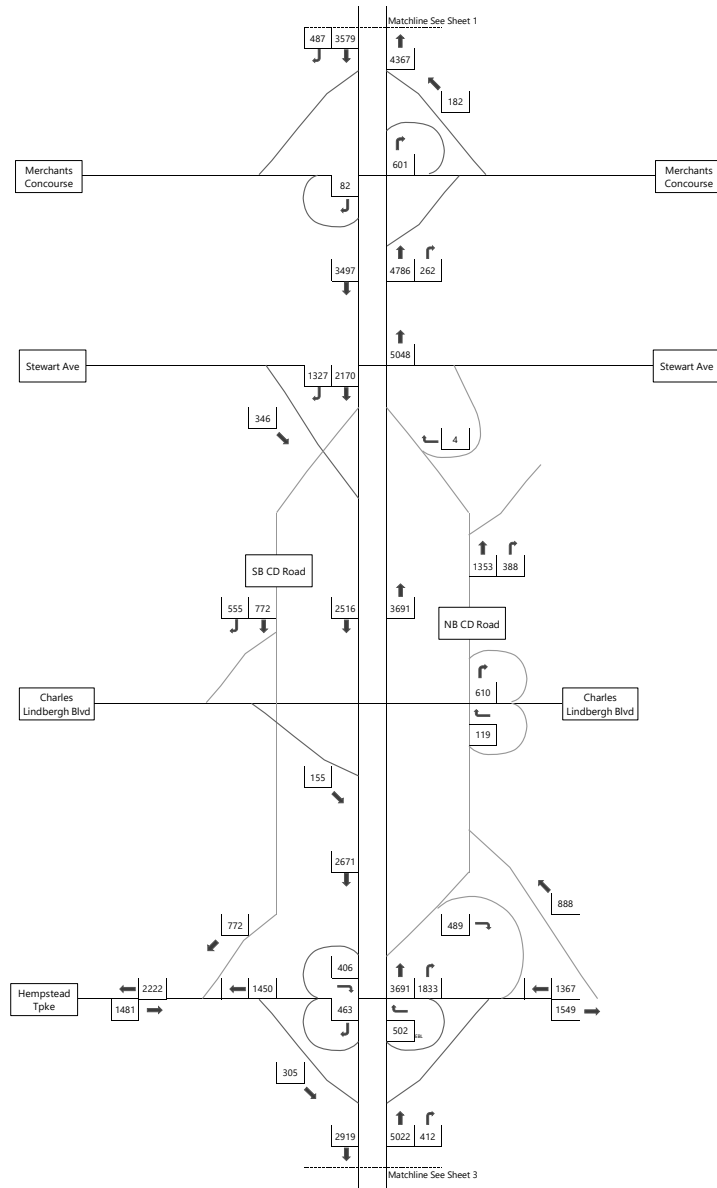

Figure V-G-1, Sheet 2
 2030 Build Parkway Traffic Volumes - Alternative
 Weekday AM Peak Hour
 26841.01 - Sands New York Integrated Resort
 Meadowbrook State Parkway



Not to Scale



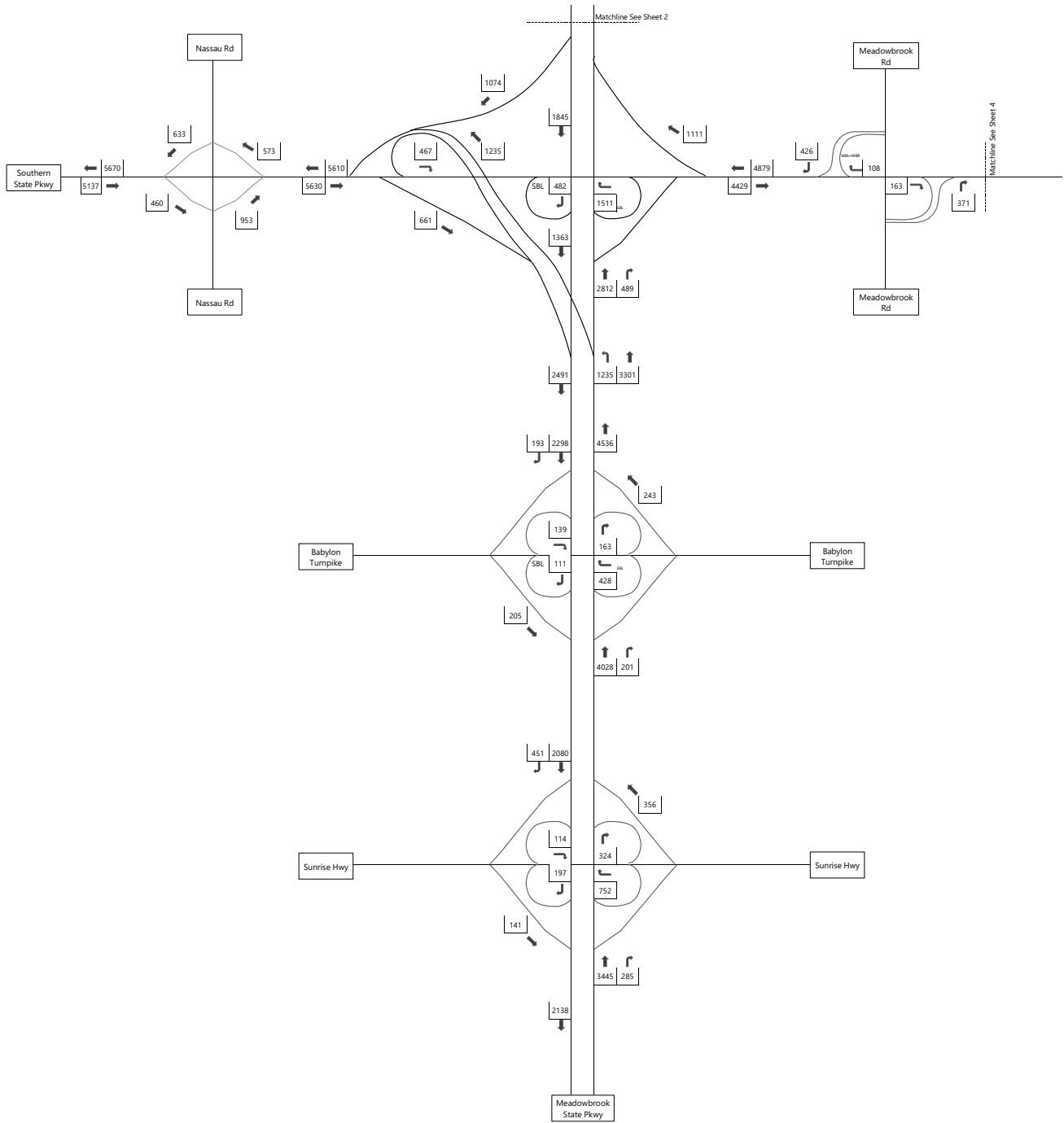

Figure V-G-1, Sheet 3
 2030 Build Parkway Traffic Volumes - Alternative
 Weekday AM Peak Hour
 26841.01 - Sands New York Integrated Resort
 Meadowbrook State Parkway



Not to Scale



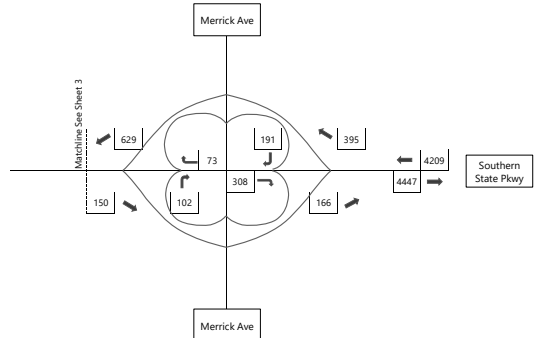
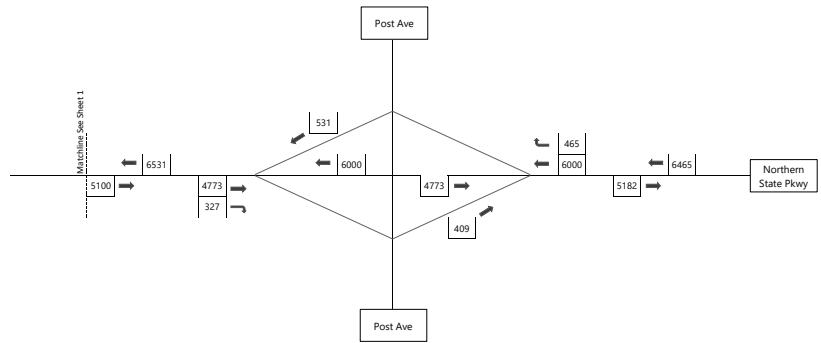

Figure V-G-1, Sheet 4
 2030 Build Parkway Traffic Volumes - Alternative
 Weekday AM Peak Hour
 26841.01 - Sands New York Integrated Resort
 Meadowbrook State Parkway



Not to Scale



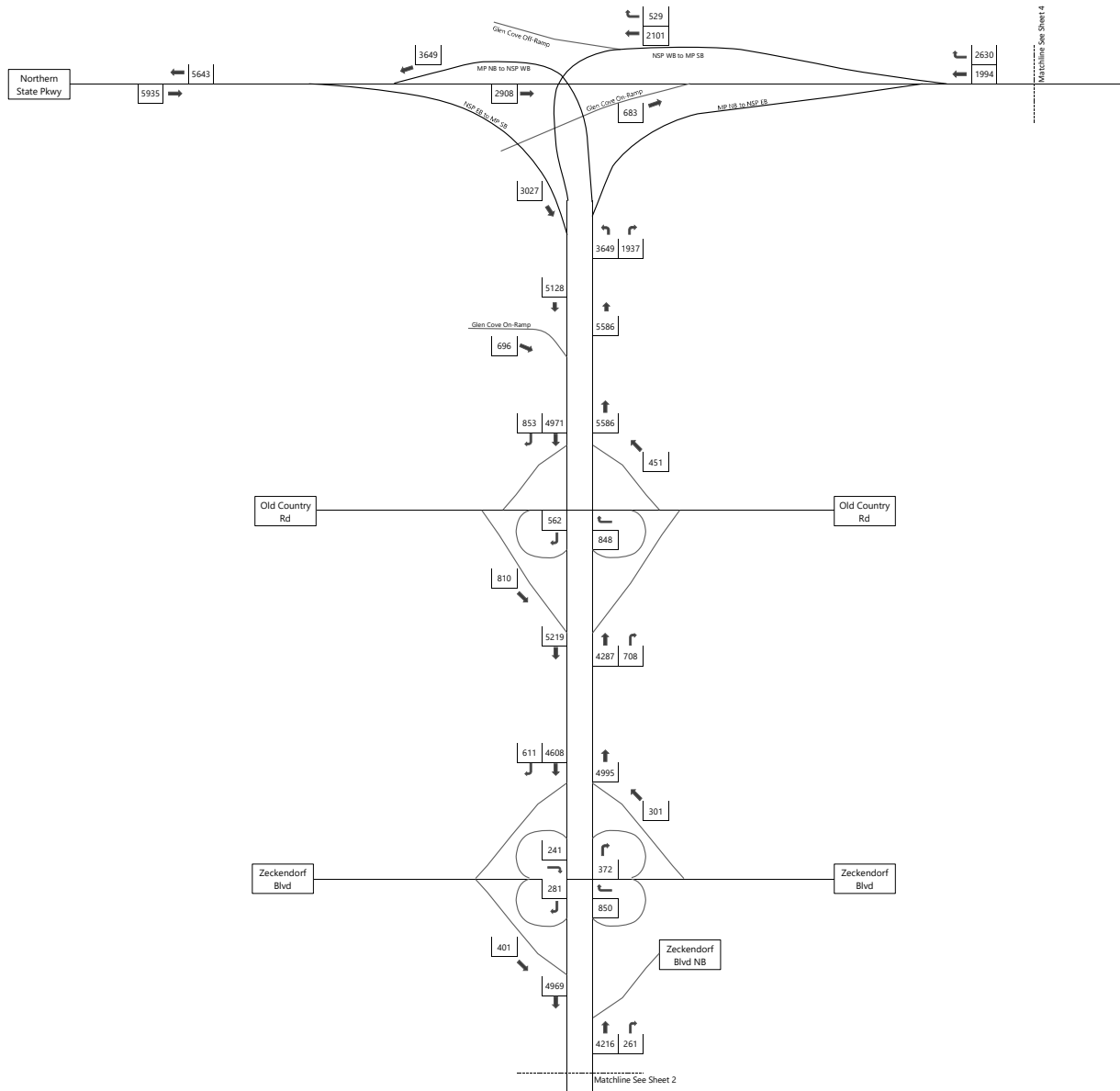

Figure V-G-2, Sheet 1
 2030 Build Parkway Traffic Volumes - Alternative
 Weekday PM Peak Hour
 26841.01 - Sands New York Integrated Resort
 Meadowbrook State Parkway



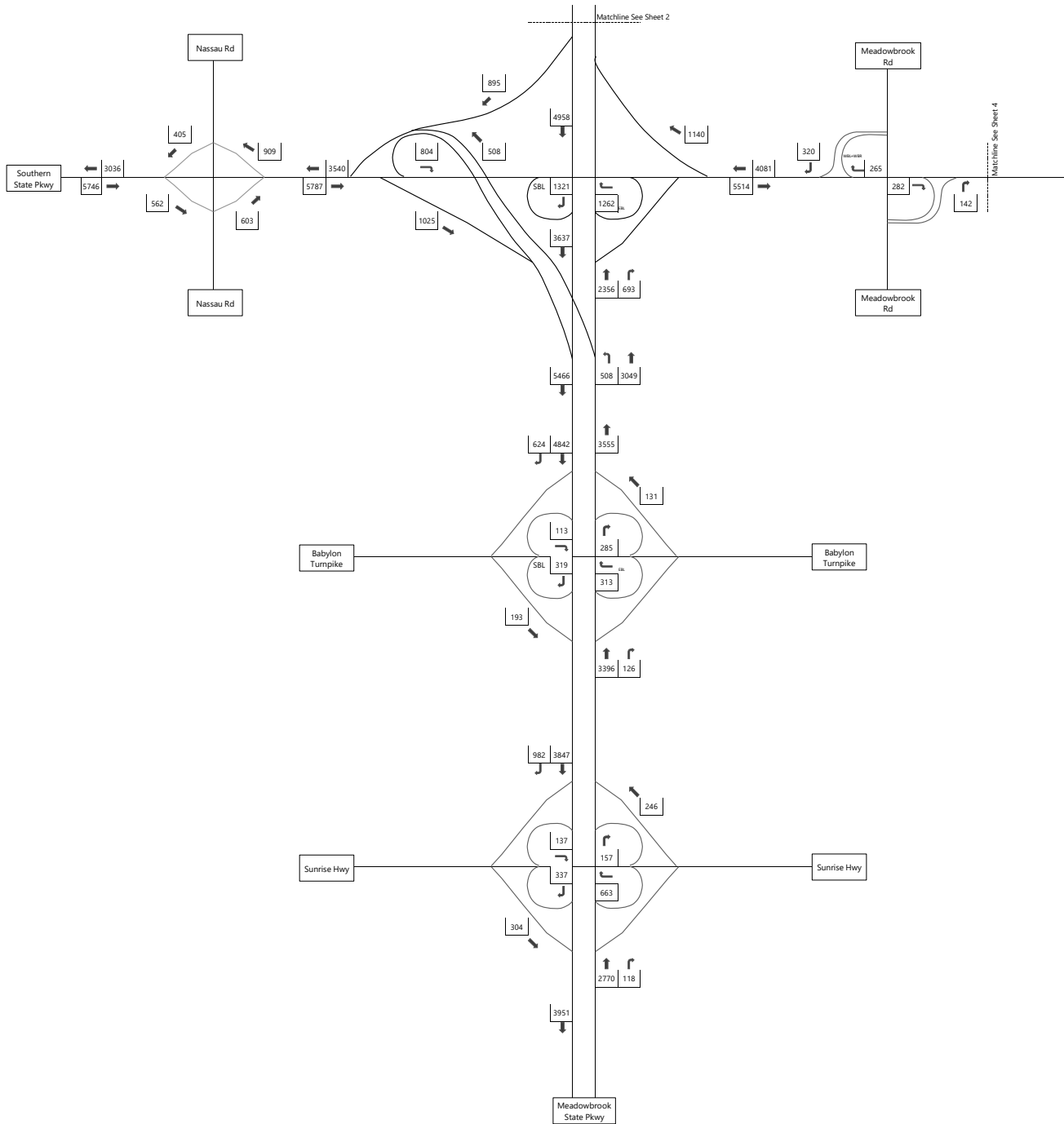

Figure V-G-2, Sheet 3
 2030 Build Parkway Traffic Volumes - Alternative
 Weekday PM Peak Hour
 26841.01 - Sands New York Integrated Resort
 Meadowbrook State Parkway



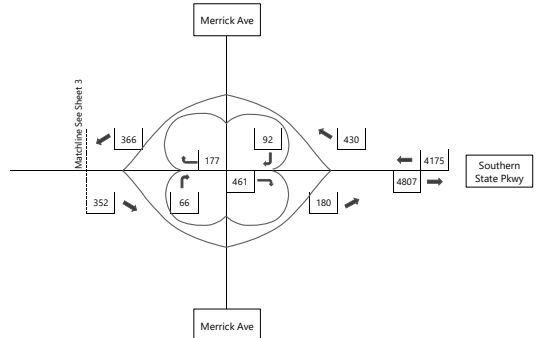
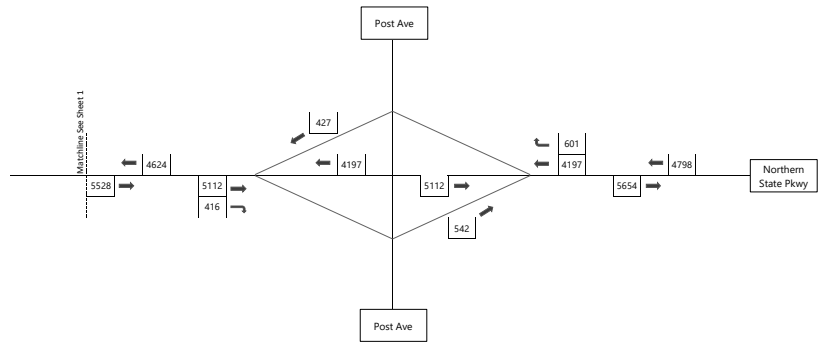

Figure V-G-2, Sheet 4
 2030 Build Parkway Traffic Volumes - Alternative
 Weekday PM Peak Hour
 26841.01 - Sands New York Integrated Resort
 Meadowbrook State Parkway



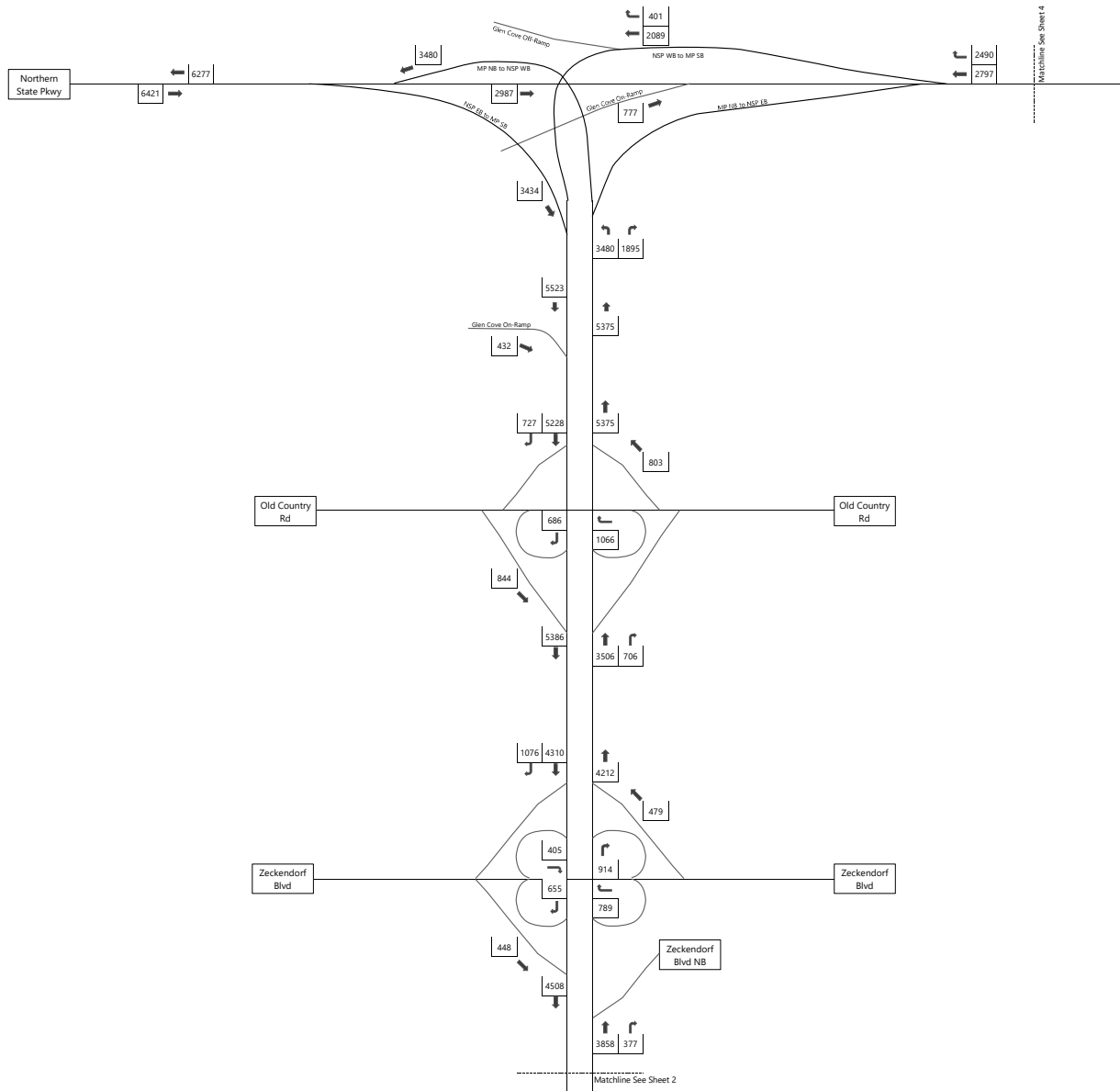

Figure V-G-3, Sheet 1
 2030 Build Parkway Traffic Volumes - Alternative
 Saturday Midday Peak Hour
 26841.01 - Sands New York Integrated Resort
 Meadowbrook State Parkway



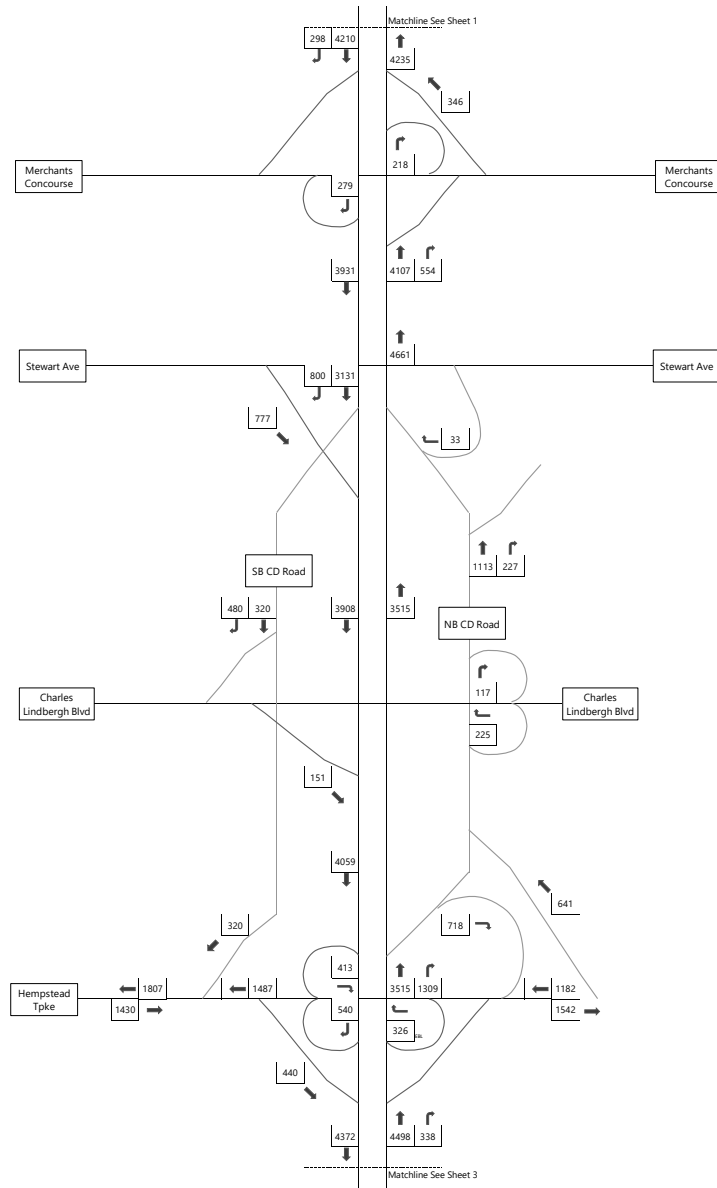

Figure V-G-3, Sheet 2
 2030 Build Parkway Traffic Volumes - Alternative
 Saturday Midday Peak Hour
 26841.01 - Sands New York Integrated Resort
 Meadowbrook State Parkway



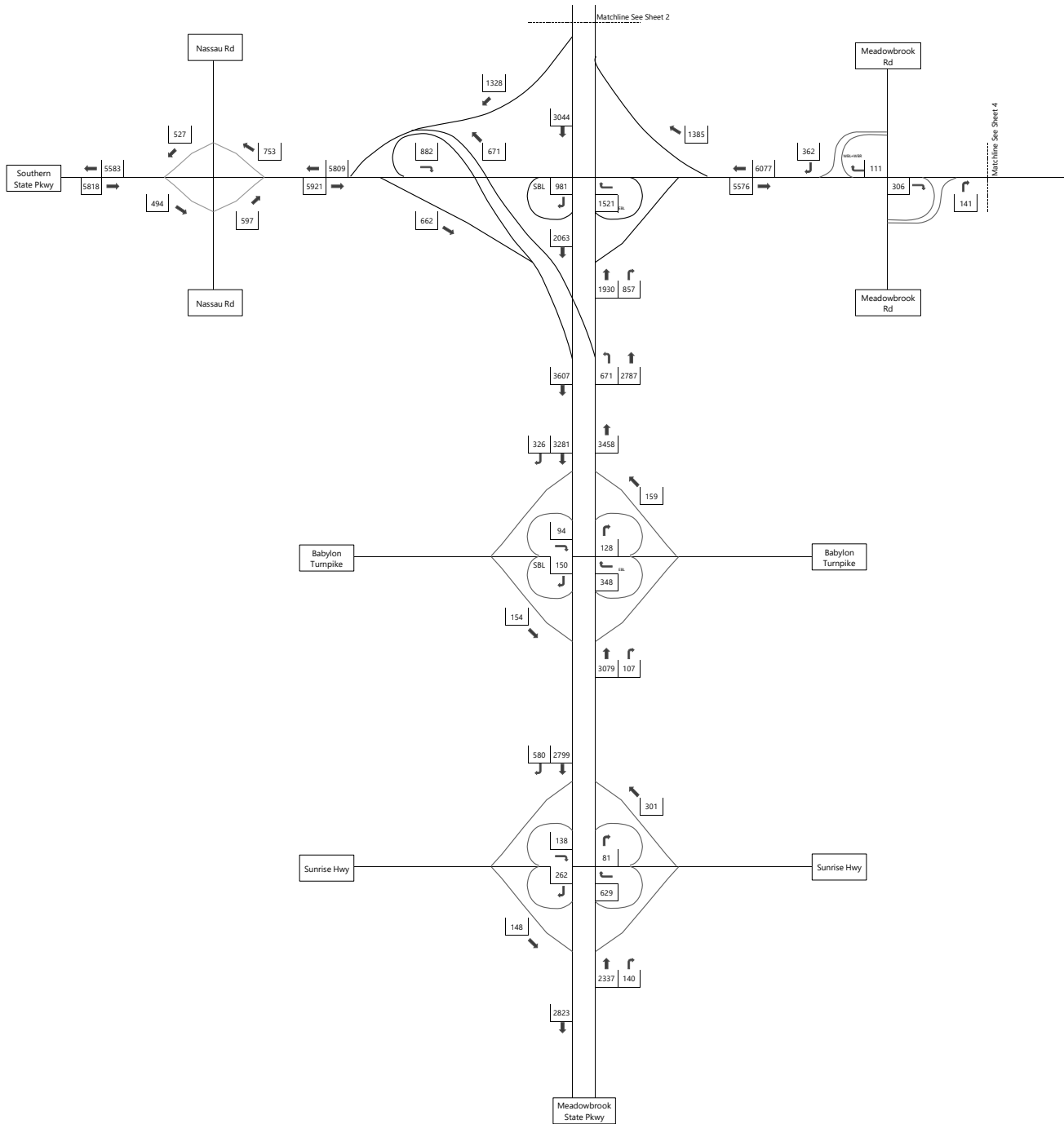

Figure V-G-3, Sheet 3
 2030 Build Parkway Traffic Volumes - Alternative
 Saturday Midday Peak Hour
 26841.01 - Sands New York Integrated Resort
 Meadowbrook State Parkway



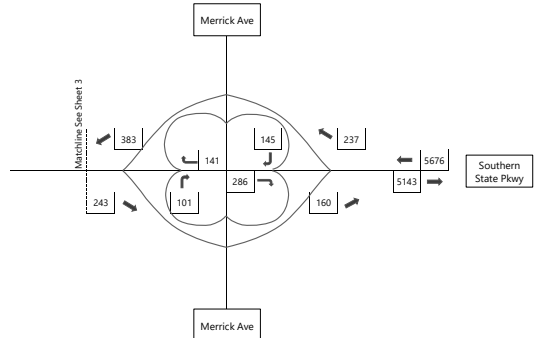
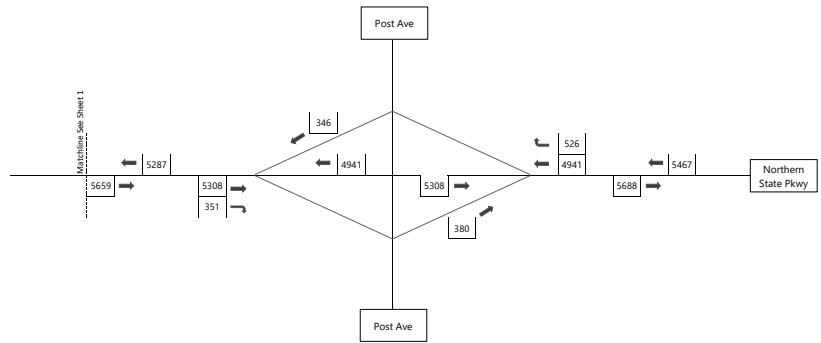

Figure V-G-3, Sheet 4
 2030 Build Parkway Traffic Volumes - Alternative
 Saturday Midday Peak Hour
 26841.01 - Sands New York Integrated Resort
 Meadowbrook State Parkway

